

Research Report – UCD-ITS-RR-14-04

---

# Modeling Optimal Transition Pathways to a Low Carbon Economy in California: California TIMES (CA-TIMES) Model

April 2014

Christopher Yang  
Sonia Yeh  
Kalai Ramea  
Saleh Zakerinia  
David McCollum  
David Bunch  
Joan Ogden

Contract # 09-346

# Modeling Optimal Transition Pathways to a Low Carbon Economy in California

## California TIMES (CA-TIMES) Model

Prepared for the California Air Resources Board and the California Environmental  
Protection Agency

Christopher Yang  
Sonia Yeh  
Kalai Ramea  
Saleh Zakerinia  
David McCollum<sup>+</sup>  
David Bunch<sup>\*</sup>  
Joan Ogden

*Institute of Transportation Studies, University of California, Davis*

<sup>+</sup> *International Institute for Applied Systems Analysis, Laxenburg, Austria*

<sup>\*</sup> *Graduate School of Management, University of California, Davis*

April 2014

### Contact Information

Principle Investigator: Sonia Yeh ([slyeh@ucdavis.edu](mailto:slyeh@ucdavis.edu))

Christopher Yang ([ccyang@ucdavis.edu](mailto:ccyang@ucdavis.edu))

Institute of Transportation Studies, University of California, Davis  
1605 Tilia Street, Suite 100  
Davis, CA 95616



## **DISCLAIMER**

The statements and conclusions in this Report are those of the contractor and not necessarily those of the California Air Resources Board. The mention of commercial products, their source, or their use in connection with material reported herein is not to be construed as actual or implied endorsement of such products.

## **ACKNOWLEDGEMENT**

This Report was submitted in fulfillment of Contract # 09-346 Modeling Optimal Transition Pathways to a Low Carbon Economy in California by the Institute of Transportation Studies under the sponsorship of the California Air Resources Board. Work was completed as of April 2014.

# TABLE OF CONTENTS

<b>LIST OF FIGURES .....</b>	<b>5</b>
<b>LIST OF TABLES.....</b>	<b>8</b>
<b>ABSTRACT .....</b>	<b>9</b>
<b>EXECUTIVE SUMMARY .....</b>	<b>10</b>
<b>ABBREVIATIONS .....</b>	<b>12</b>
<b>1. INTRODUCTION .....</b>	<b>13</b>
1.1 BACKGROUND AND MOTIVATION .....	14
1.2 CURRENT SNAPSHOT OF CALIFORNIA ENERGY USE AND GHG EMISSIONS .....	15
1.3 DRIVERS FOR FUTURE ENERGY DEMANDS AND EMISSIONS .....	17
1.4 STUDY GOALS.....	17
<b>2. MODEL STRUCTURE AND MODELING APPROACHES.....</b>	<b>19</b>
2.1 PRIMARY MODELING APPROACH: OPTIMIZATION .....	20
2.2 ALTERNATIVE MODELING APPROACH: PARTIAL EQUILIBRIUM WITH ELASTIC DEMAND (ED).....	22
2.3 USER CONSTRAINTS AND OTHER TECHNIQUES TO APPROXIMATE MARKETS AND BEHAVIORS.....	24
<b>3. ENERGY SUPPLY.....</b>	<b>26</b>
3.1 OIL AND NATURAL GAS.....	27
3.1.1 <i>Supply curves</i> .....	27
3.1.2 <i>Oil refineries</i> .....	27
3.2 BIOMASS AND BIOFUELS .....	29
3.2.1 <i>Biomass supply curves</i> .....	29
3.2.2 <i>Biorefineries</i> .....	30
3.3 HYDROGEN PRODUCTION .....	31
3.4 ELECTRICITY GENERATION.....	33
3.4.1 <i>Timeslices</i> .....	34
3.4.2 <i>Power plants</i> .....	35
3.4.3 <i>Renewable wind and solar resources and transmission</i> .....	36
3.4.4 <i>New power plant costs and efficiency</i> .....	38
3.4.5 <i>Electricity imports</i> .....	39
3.5 GREENHOUSE GAS (GHG) EMISSIONS.....	40
<b>4. DEMAND SECTORS.....</b>	<b>42</b>
4.1 TRANSPORTATION.....	42
4.1.1 <i>Light-duty cars and trucks</i> .....	42
4.1.2 <i>Motorcycles</i> .....	43
4.1.3 <i>Medium-duty vehicles and heavy-duty vehicles</i> .....	43
4.1.4 <i>Buses</i> .....	43
4.1.5 <i>Passenger rail</i> .....	44
4.1.6 <i>Domestic freight (air, rail and shipping)</i> .....	45
4.1.7 <i>Domestic (interstate and intrastate) passenger aviation</i> .....	45
4.1.8 <i>Natural gas pipelines</i> .....	45
4.1.9 <i>Other transportation</i> .....	45
4.2 RESIDENTIAL END USE SECTOR .....	47
4.2.1 <i>End-use demand drivers</i> .....	49
4.2.2 <i>Temporal resolution of end-use demands</i> .....	53
4.2.3 <i>Characteristics of end-use technology</i> .....	54

4.2.4	<i>Calibration to 2010</i> .....	55
4.2.5	<i>Levelized cost and growth constraints</i> .....	56
4.3	COMMERCIAL END USE SECTOR.....	57
4.3.1	<i>End-use demand by time slice</i> .....	60
4.3.2	<i>Technology characteristics</i> .....	61
4.4	INDUSTRIAL SECTOR.....	62
4.5	AGRICULTURAL AND NON-ENERGY SECTOR.....	63
<b>5.</b>	<b>SCENARIOS</b> .....	<b>65</b>
5.1	REFERENCE SCENARIO.....	65
5.1.1	<i>Reference scenario policies</i> .....	66
5.2	GREENHOUSE GAS SCENARIOS.....	67
5.2.1	<i>Greenhouse Gas Scenarios Policies</i> .....	67
5.3	SCENARIO VARIATIONS.....	69
<b>6.</b>	<b>RESULTS</b> .....	<b>71</b>
6.1	PRIMARY SCENARIOS.....	71
6.1.1	<i>Transportation Sector</i> .....	73
6.1.2	<i>Commercial, Residential, Industrial and Agricultural Sectors</i> .....	80
6.1.3	<i>Electric Sector</i> .....	85
6.1.4	<i>Fuels Supply Sector</i> .....	89
6.1.5	<i>Energy System Costs</i> .....	93
6.2	<i>Sensitivity Scenarios</i> .....	97
6.2.1	<i>New nuclear power</i> .....	97
6.2.2	<i>Carbon capture and sequestration</i> .....	98
6.2.3	<i>High renewable electricity growth</i> .....	100
6.2.4	<i>Higher biomass supply</i> .....	100
6.2.5	<i>Oil and gas prices</i> .....	101
6.2.6	<i>Elastic demand (ED)</i> .....	102
6.2.7	<i>Comparison between sensitivity scenarios</i> .....	103
<b>7.</b>	<b>NON-CORE EXPERIMENTAL TIMES MODELS/SCENARIOS</b> .....	<b>111</b>
7.1	HYDROGEN INFRASTRUCTURE MODEL.....	111
7.2	CONSUMER CHOICE MODEL FOR LIGHT-DUTY VEHICLE.....	111
7.3	FLEXIBLE PLUG-IN ELECTRIC VEHICLE CHARGING.....	112
<b>8.</b>	<b>SUMMARY, CONCLUSIONS AND FUTURE WORK</b> .....	<b>113</b>
8.1	DISCUSSION OF MODELING APPROACH.....	113
8.2	SUMMARY OF RESULTS AND CONCLUSIONS.....	114
8.3	FUTURE WORK.....	116
<b>9.</b>	<b>REFERENCES</b> .....	<b>118</b>

**LIST OF APPENDICES (IN SEPARATE FILE)**

- APPENDIX A. COST OF ELECTRICITY GENERATION TECHNOLOGIES
- APPENDIX B. ASSUMPTIONS OF TRANSPORTATION TECHNOLOGY COSTS, EFFICIENCY, HURDLE RATES, ELASTICITIES, AND GROWTH/CAPACITY CONSTRAINTS
- APPENDIX C. ASSUMPTIONS OF RESIDENTIAL AND COMMERCIAL TECHNOLOGY COSTS, HURDLE RATES, ELASTICITIES, AND GROWTH/CAPACITY CONSTRAINTS
- APPENDIX D. POLICY DESCRIPTIONS FOR CA-TIMES SCENARIOS
- APPENDIX E. MORE DETAILED SCENARIO RESULTS
- APPENDIX F. NON-CORE EXPERIMENTAL TIMES MODELS/SCENARIOS

## LIST OF FIGURES

Figure 1.1. Total energy consumption (left) and fossil energy (right) (including energy losses associated with electric generation, transmission, and distribution) for California, 2010. Total energy consumption in 2010 is 7846 Trillion Btu (left), of which 85% comes from fossil energy (right, 5854 trillion Btu). Source: EIA (2013). .....	16
Figure 1.2. State-level GHG emissions in 2010. Source: (CARB 2013). Total emissions are 449.37 million metric tonnes CO <sub>2</sub> equivalent and 500.74 million metric tonnes CO <sub>2</sub> equivalent when domestic and international aviation and international marine bunker fuel use are included.....	16
Figure 1.3. Historical trend of California population, GDP (in constant dollar), primary energy use and GHG emissions (left) and energy use per capita and per GDP. Source: (CA DOF 2013, CARB 2013). .....	17
Figure 2.1. Schematic diagram of CA-TIMES model (version 1.5). .....	19
Figure 2.2. Equilibrium when an energy service demand ( $Q_E$ ) is fixed. Source: (Loulou, Remne et al. 2005)....	21
Figure 2.3. Illustration of supply-demand equilibrium with elastic demand. Source: modified based on Kesicki and Anandarajah (2011). .....	23
Figure 3.1. Schematic Representation of CA-TIMES Model. .....	26
Figure 3.2. Crude oil (left) and natural gas (right) price projections assumed in CA-TIMES v1.5. Source: (EIA 2013). Dashed lines represent our own extrapolation from 2040 to 2055.....	27
Figure 3.3. Simplified schematic of flexible refinery technology in CA-TIMES.....	28
Figure 3.4. Biomass supply curves for California and neighboring states available for bioenergy purposes in California in 2050. ....	30
Figure 3.5. Simplified schematic of hydrogen production and supply technologies in CA-TIMES.....	32
Figure 3.6. Schematic of electric sector resources, conversion plants and end use sectors.....	33
Figure 3.7. Load duration curve of historical large hydroelectric power generation in California. Data from CAISO (CAISO 2013). .....	36
Figure 3.8. Structure of remote renewables for wind, solar PV and solar thermal power plants in Competitive Renewable Energy Zones (CREZ) groups.....	37
Figure 3.9. CA-TIMES model structure and emissions categories.....	40
Figure 4.1. Vehicle miles traveled demand of light-duty cars and trucks. ....	43
Figure 4.2. Vehicle-miles traveled data for modes other than light-duty sector vehicles .....	44
Figure 4.3. The structure of residential RES describing energy service demands, fuel types and technologies in California. “Demand drivers” are exogenous to the model. ....	47
Figure 4.4. Residential energy service demand projections 2010-2050 (top: all end-use except lighting, bottom: lighting). .....	52
Figure 4.5. Shares of heating demand in a given year for the seasonal time slice (by-monthly) used in CA-TIMES .....	53
Figure 4.6. Calibrated residential end- use by fuel type, 2010. ....	56
Figure 4.7. Structure of energy demand and supply for CA-TIMES v1.5 commercial sector. ....	58
Figure 4.8. Floor space projection by building type. SOFF: Small Offices, REST: Restaurants, RETL: Retail, GROC: Groceries, WARE: Warehouses, SCHL: Schools, HLTH: Hospitals and Health, LODG: Hotels, REFW: Refrigerated warehouses, MISC: Miscellaneous, LOFF: Large Offices. ....	59
Figure 4.9. Commercial service demand projected to 2050. Note: most service demands are in PJ, but lighting and ventilation service demands are in different units (billion lumen-yr and trillion CFM-yr). .....	60
Figure 4.10. Daily variation of service demand for retail commercial building in January and February. The daily time period is grouped into three-hour time slices. Thus the daily time period 1 corresponds to 12 am-3 am, and so on.....	61
Figure 4.11. Commercial fuel use by end use, 2010. ....	62
Figure 4.12. Industrial final energy demand assumed in the BAU (top) and GHG policy (bottom) scenarios....	63
Figure 4.13. Agriculture final energy demand assumed in the BAU (top) and GHG policy (bottom) scenarios.	64
Figure 5.1. Carbon cap by year for the GHG policy scenarios, GHG-Line and GHG-Step. Both achieve 80% reduction from 1990 emissions levels by 2050. ....	68
Figure 6.1. Included Instate GHG emissions from 2010 to 2050 by sector for the Reference scenario. Instate emissions include shipping and aviation emissions not included in the State’s GHG emission inventory. ....	71

Figure 6.2. Included Instate GHG emissions from 2010 to 2050 by sector for the 80% GHG reduction Step scenario (GHG-Step).	72
Figure 6.3. Included Instate GHG emissions from 2010 to 2050 by sector for the 80% GHG reduction Linear scenario (GHG-Line).	73
Figure 6.4. Comparison of Included Instate GHG emissions for the three primary CA-TIMES scenarios.	73
Figure 6.5. Transportation fuel consumption in Reference (BAU) scenario.	74
Figure 6.6. Transportation fuel consumption in 80% GHG step reduction scenario (GHG-Step).	75
Figure 6.7. Transportation fuel consumption in 80% GHG linear reduction scenario (GHG-Line).	75
Figure 6.8. Comparison of the carbon intensity of transportation fuels in the three primary CA-TIMES scenarios.	76
Figure 6.9. Light-duty vehicle VMT by vehicle type in Reference (BAU) scenario.	77
Figure 6.10. Light-duty vehicle VMT by vehicle type in 80% GHG step reduction scenario (GHG-Step).	77
Figure 6.11. Light-duty vehicle VMT by vehicle type in 80% GHG Linear Reduction Scenario (GHG-Line).	78
Figure 6.12. Comparison of light-duty vehicle fleet fuel economy (on-road) for the three primary scenarios.	78
Figure 6.13. Comparison of the carbon per mile and miles traveled for different vehicle types and total emissions from LDVs in 2010, 2030 and 2050 for the GHG-Step scenario.	79
Figure 6.14. Comparison of the fuel economy in heavy-duty and medium-duty trucks and intrastate passenger aircraft for three primary scenarios.	80
Figure 6.15. Final energy (fuel) demands for commercial, residential, industrial and agricultural sectors in the Reference scenarios.	80
Figure 6.16. Final energy (fuel) demands for commercial, residential, industrial and agricultural sectors in the GHG-Step scenario.	81
Figure 6.17. Final energy (fuel) demands for commercial, residential, industrial and agricultural sectors in the GHG-Line scenario.	82
Figure 6.18. Indexed weighted efficiency in the residential and commercial sectors in the three primary scenario.	82
Figure 6.19. Commercial sector final energy use by energy services in the Reference (BAU) scenario.	83
Figure 6.20. Residential sector final energy use by energy services in the Reference (BAU) scenario.	83
Figure 6.21. Commercial sector final energy use by energy services in the GHG-Step scenario.	84
Figure 6.22. Residential sector final energy use by energy services in the GHG-Step scenario.	84
Figure 6.23. Electricity generation by resource type in the Reference (BAU) scenario.	85
Figure 6.24. Electricity generation by resource type in the 80% GHG Step Reduction Scenario (GHG-Step).	86
Figure 6.25. Electricity generation by resource type in the 80% GHG Linear Reduction Scenario (GHG-Line).	86
Figure 6.26. Carbon intensity of electricity generation in three primary CA-TIMES scenarios.	87
Figure 6.27. Electricity generation by resource type and timeslice in the Reference (BAU) scenario in 2050. See section 3.5.5 for more info on timeslices. JF: January/February; MA: March/April; MJ: May/June; JA: July/August; SO: September/October; ND: November/December. The daily time period is grouped into three-hour time slices. Thus the daily time period 1 (T1) corresponds to 12 am-3 am, and so on.	88
Figure 6.28. Electricity generation by resource type and timeslice for 2050 in the 80% GHG-Step Reduction Scenario (GHG-Step).	88
Figure 6.29. Electricity generation by resource type and timeslice in the 80% GHG Linear Reduction Scenario (GHG-Line).	89
Figure 6.30. Annual biofuel production by category for the Reference (BAU) scenario.	90
Figure 6.31. Annual biofuel production by category for the 80% GHG-Step Reduction Scenario (GHG-Step).	90
Figure 6.32. Annual biofuel production by category for the 80% GHG-Step Reduction Scenario (GHG-Line).	91
Figure 6.33. Annual share of primary energy resources for the Reference (BAU) scenario.	91
Figure 6.34. Annual share of primary energy resources for the 80% step GHG emissions reduction (GHG-Step) scenario.	92
Figure 6.35. Annual share of primary energy resources for the 80% linear GHG emissions reduction (GHG-Line) scenario.	92
Figure 6.36. Annual cost difference between GHG-Step and BAU scenarios broken down by sector.	95
Figure 6.37. Annual cost difference between GHG-Line and BAU scenarios broken down by sector.	95
Figure 6.38. Annual cost difference between GHG-Step and BAU-LoVMT scenarios broken down by sector.	96
Figure 6.39. Annual cost difference between GHG-Line and BAU-LoVMT scenarios broken down by sector.	97

Figure 6.40. Electricity generation by resource type in the 80% Step GHG emissions reduction scenario with nuclear power (GHG-S-Nuclear). .....	98
Figure 6.41. Electricity generation by resource type in the 80% Step GHG emissions reduction scenario with carbon capture and sequestration (GHG-S-CCS). .....	99
Figure 6.42. Electricity generation by resource type in the 80% Step GHG emissions reduction scenario with higher renewable deployment (GHG-S-HiRen). .....	100
Figure 6.43. Transportation fuel mix in the High Biomass 80% Step GHG Emissions Reduction Scenario (GHG-S-HiBio). .....	101
Figure 6.44. California cumulative GHG emissions (from Included and out-of-state transport sources) and 2050 emissions reduction from 1990 levels. ....	104
Figure 6.45. California annual GHG emissions and 2050 emissions reduction from 1990 levels.....	105
Figure 6.46. California primary energy resource usage by sensitivity scenarios (for 2050).....	105
Figure 6.47. California transportation fuel usage and carbon intensity by sensitivity scenarios (for 2050)..	106
Figure 6.48. California electricity generation mix and carbon intensity by sensitivity scenarios (for 2050)..	107
Figure 6.49. California light-duty vehicle fleet share by sensitivity scenarios (for 2050). ....	107
Figure 6.50. Average cost of emission reduction (\$/ton CO2) between 2010-2050 comparing with BAU and BAU-LoVMT scenario. Also shown are the discounted costs (r=4%) compares with BAU (blue dots) and with BAU-LoVMT (red diamonds).....	109
Figure 6.51. GHG mitigation costs vs BAU, discounted by scenario over GHG scenarios. Elasticity scenarios include consumer utility loss associated with reduced service demand.....	110



## LIST OF TABLES

Table 1.1. California statewide energy-economic-environment models that have been applied to analyze state energy and climate policies.....	15
Table 2.1. An example of technology-specific discount rate, CRF, the annual payment and perceived net present value by consumers (assuming ELIFE = 15, investment cost = 1 M\$).....	25
Table 3.1. Assumptions of refinery inputs and maximum shares of outputs in 2010 and 2055.....	29
Table 3.2. Biorefineries and Fischer-Tropsch (FT) poly-generation plants in CA-TIMES.....	31
Table 3.3. Electric Generation Technologies in CA-TIMES.....	35
Table 3.4. List of each CREZ group with solar and wind capacity, availability and transmission cost.....	38
Table 3.5. Capital investment and plant efficiency assumptions for new power plants.....	39
Table 3.6. Emissions bins tracked in CA-TIMES.....	41
Table 4.1. Summary of data sources for transportation demand and technology by subcategory.....	46
Table 4.2. Characteristics of residential sector: fuel use, technology, service demand and demand drivers.....	49
Table 4.3. Number of dwelling units and housing unit size, 2010 - 2050.....	50
Table 4.4. Estimated housing heating and cooling coefficient and percent changes, 2010-2050.....	50
Table 4.5. Percent changes in appliance saturation rates by dwelling type and by end-use, 2010-2050.....	51
Table 4.6. Projected changes in lighting demand from 2010 level.....	51
Table 4.7. Estimated relative percent changes in appliance utilization rate, 2010-2050.....	52
Table 4.8. Seasonal and hourly profiles of residential cooling demand modeled in CA-TIME time slices.....	54
Table 4.9. Technology parameters describing residential end-use technologies.....	54
Table 4.10. Definitions of efficiency of end-use technologies.....	54
Table 4.11. Efficiency metrics describing residential end-use technologies.....	55
Table 4.12. Commercial building types and end-use energy services.....	57
Table 4.13. Technology parameters describing commercial end-use technologies.....	61
Table 5.1. List of choices that define a scenario's inputs and influence the optimization model results.....	65
Table 5.2. Brief descriptions of policies represented in the CA-TIMES v1.5 reference scenario.....	66
Table 5.3. Sensitivity parameters for GHG scenarios. "GHG-S" represents scenarios with a "Step" constraint on GHG emissions as described in the previous section, and "GHG-L" represents scenarios with a "Line" constraint on GHG emissions between 2020-2050.....	70
Table 6.1. Summary of undiscounted and discounted (present value at 4% discount rate) energy system costs (in 2010\$) and cumulative emissions for primary CA-TIMES scenarios for 2010 to 2050.....	93
Table 6.2. Summary of undiscounted energy system costs (in 2010\$) and cumulative emissions for primary CA-TIMES scenarios for 2010 to 2050.....	94
Table 6.3. Table of cumulative emissions, total system costs and cost and emissions differences for various sensitivity scenarios.....	108

## **ABSTRACT**

An optimization model of the California Energy System (CA-TIMES) is used to understand how California can meet the 2050 targets for greenhouse gas (GHG) emissions (80% below 1990 levels). This model represents energy supply (energy resources, electricity generation, and fuel production and infrastructure) and energy demand (commercial, residential, transportation, industrial and agriculture sectors) in California and simulates the technology and resource requirements needed to meet projected energy service demands. These model choices vary based upon policy constraints (e.g., a carbon cap, fuel economy standards, renewable electricity requirements), as well as technology and resource costs and availability. Multiple scenarios are developed to analyze the changes and investments in low-carbon electricity generation, alternative fuels and advanced vehicles in transportation, resource utilization, and efficiency improvements across many sectors. Results show that major energy transformations are needed but that achieving the 80% reduction goal for California is possible at reasonable average carbon reduction cost (-\$75 to \$124/tonne CO<sub>2</sub> discounted cost) relative to the baseline scenarios. Availability of low-carbon resources such as nuclear power, carbon capture and sequestration, and increased availability of biofuels and wind and solar generation all serve to lower the mitigation costs.

## **EXECUTIVE SUMMARY**

### **BACKGROUND**

California's ambitious Global Warming Solutions Act sets targets for reducing greenhouse gas (GHG) emissions by 2020, and the state has set up strong policy mechanisms to achieve this goal. Meeting the goal of climate stabilization requires deep reductions in GHG emissions well below current levels, and the state has set a longer-term goal of an 80% reduction in GHG emissions below 1990 levels by 2050. Considerable uncertainty exists as to how these deep reductions can be achieved and the most cost-effective means to do so. While a number of studies have tried to quantify the potential and costs of various mitigation options (e.g., efficiency, renewable electricity, advanced vehicles and alternative fuels) to reduce GHG emissions, no comprehensive model of the California energy system existed to analyze all of the potential mitigation options in an integrated manner. An integrated energy system approach that looks at energy supply sectors (electricity, natural gas and fuels) and energy demand sectors (buildings, transportation, industry) is needed to understand the interactions between various sectors as they decarbonize and help the California Air Resources Board (ARB) to devise policies to help bring about the energy system transformations needed to meet the 2050 target.

### **OBJECTIVES AND METHODS**

The objective of this study is to use the CA-TIMES model to explore scenarios to understand the role of various technology and policy options for reducing GHG emissions while meeting the future energy demand in California by 2050. The research team developed the CA-TIMES model, which involves creating a mathematical model of the structure and operation of the future California energy system to 2050. The CA-TIMES model is an energy systems model representing all sectors of the California energy economy, including energy supply (energy resources, fuel production/conversion, electricity production, and fuel delivery), and demand (residential, commercial, transportation, industrial, and agricultural end-use sectors). The model is an optimization model that minimizes the cost of supplying all of the technologies, resources, infrastructure, and end-use technology needed to meet future demand given constraints in resources and technology availability, policy, etc.

The CA-TIMES model was used to explore different scenarios of future energy systems in California. Reference scenarios were developed to understand how the energy system might look in the absence of climate policy past 2020. GHG scenarios were developed to understand how the state might meet the 80% GHG reduction target in 2050. A number of GHG scenarios were developed to investigate the role that specific technologies and resources, such as nuclear power, carbon capture and sequestration, biomass, and renewables, might play in meeting the GHG target. Scenarios with demand reduction (specifically low vehicle miles traveled (VMT) and demand elasticity scenarios) were also investigated in order to understand the role that they might play in reducing emissions and the effects on the costs of GHG mitigating compared to purely technology solutions. These scenarios are then compared to one another with respect to emissions reductions, costs, and the mix of technologies and resources used to reduce emissions.

### **RESULTS**

The CA-TIMES model scenarios show that achieving an 80% reduction in GHG emissions in California requires major transformations in the energy system. On the energy supply side, notable changes include major investments in renewable and low-carbon electricity generation, biofuels production and hydrogen production. Electricity demand increases significantly in GHG scenarios, and 60-90% of electricity comes

from renewable electricity resources, with only a small contribution from natural gas generation. Significant increases in transportation efficiency reduce total transportation fuel demand 20-30% from current levels, even accounting for population and demand growth. Biofuels grow to make up 30-50% of the transportation fuel demand (~6-10 billion gallons of gasoline equivalent) in these scenarios (CA-TIMES includes an estimate of indirect land use change emissions associated with some crop-based biofuels). On the energy demand side, there are substantial increases in efficiency across all sectors, increasing electrification of transportation and buildings, the use of advanced vehicles and low-carbon fuels (such as hydrogen and electric vehicles) and more efficient trucks, buses, ships, trains and planes. In most scenarios, light-duty vehicles are met primarily through zero-emission vehicles (40% battery electric and up to 50% from fuel cell vehicles). In heavy-duty and medium-duty vehicles, vehicle efficiency nearly doubles by 2050 and the carbon intensity of all transportation fuels declines 40-50%. With all these major changes, the primary GHG scenarios (which exclude nuclear power and carbon capture and sequestration) achieve quite significant reductions in GHG emissions (75% below 1990 levels). Meeting the 80% reduction target is possible with additional availability of low-carbon energy resources/technologies such as nuclear power, carbon capture and sequestration or increased supplies of wind and solar electricity generation and biomass. Carbon capture and sequestration appears to be one of the key technologies that can enable the state to meet the emissions target at fairly low cost, in part because it enables negative emissions (essentially offsets) in the production of biofuels with carbon capture and sequestration (CCS). Elastic demand scenarios are also examined to reflect more realistic consumers' demand reduction behaviors in response to price increases from GHG mitigation. These scenarios suggest that large reductions in emissions and cost savings are possible with demand reduction. Across all of the 80% GHG reduction scenarios, total cumulative emissions reductions relative to the business-as-usual (BAU) scenario are 2800 to 4229 million tonnes of CO<sub>2</sub> and mitigation costs range from -\$75 to \$124/tonne CO<sub>2</sub>e when costs are discounted at 4%.

## CONCLUSIONS

The CA-TIMES model was used to generate and analyze a number of scenarios of the California energy system to 2050. Some scenarios looked at futures in which no further action was taken to reduce GHG emissions (Reference/BAU scenarios) beyond 2020 and others in which annual emissions are capped to meet an 80% reduction in GHG emissions by 2050 (GHG scenarios). These scenarios are not meant to be a forecast of the future, but rather to help the state and the ARB explore the likely mix of technologies and resources that may be used to achieve very low GHG emissions in 2050 and their associated costs. The results of the scenarios suggest that the 80% GHG reduction target is achievable using foreseeable and incremental improvements to current and near-commercial technologies at a modest level of costs. The primary GHG scenarios achieve significant cost reductions at incremental costs above the BAU scenarios that range from 0.01% to 0.5% of gross state product (GSP) (discounted at 4%). Accounting for the state's expected population growth, this amounts to an average of -\$5 to \$177 per resident per year (discounted at 4%). These costs do not include the incremental costs associated with efficiency improvements and technology changes in the industrial and agricultural sectors, the two sectors that we have not analyzed the abatement costs in detail.

Recommendations for further research in analyzing scenarios for GHG reductions from California's energy system include (i) quantifying air quality, water use and other sustainability impacts of future energy systems, (ii) improvement in representation of behavior in system models to understand their role in mitigating GHG emissions (including travel demand, demand reduction and elasticity, and heterogeneity in consumers' attitudes toward the adoption of new technologies).

## ABBREVIATIONS

4E: Energy, economy, environment, engineering	IEA: International Energy Agency
AB32: Global Warming Solutions Act	IGCC: Integrated gasification combined cycle
AC: Air conditioner	kWh: kilowatt-hour
AFA: Annual availability factor	LCFS: Low Carbon Fuel Standard
AFUE: Annual fuel utilization efficiency	LDV: Light-duty vehicle
BAU: Business-as-usual	LNG: Liquefied natural gas
BEV: Battery electric vehicles	LPG: Liquefied petroleum gas
BTL: Biomass-to-liquid	LWR: Light water reactor
BTU: British thermal unit	MDV: Medium-duty vehicle
CAFE: fuel economy standards	MFH: Multi-family housing
CARB: California Air Resources Board	MMT: million metric tonnes
CBTL: Coal/biomass-to-liquid	MPMT: Million passenger miles traveled
CCS: Carbon capture and sequestration	MSW: Municipal solid waste
CEFF: Commodity-based efficiency	MTMT: Million-ton-miles traveled
CDD: Cooling degree days	MVMT: Million vehicle miles traveled
CF: Capacity factor	NGCC: Natural gas combined cycle power plant
CHP: Combined heat and power	NGGT: Natural gas combustion (gas) turbine
CI: Carbon intensity	NGST: Natural gas steam turbine
CO <sub>2e</sub> : Carbon dioxide equivalent	O&M: Operation and maintenance
COP: Coefficient of performance	OT: Once-through
CREZ: Competitive Renewable Energy Zones	PBMR: Pebble bed modular reactor
CRF: Capital Recovery Factor	PHEV: Plug-in hybrid electric vehicle
ED: Elastic demand	RC: Recycle
EER: Energy efficiency ratio	RECS: Residential Energy Consumption Survey
EF: Energy efficiency	RES: Reference energy system
EFF: Energy efficiency	RFO: Residual fuel oil
EIA: Energy Information Administration	RPS: Renewable Portfolio Standard
FAF3: Freight Analysis Framework	RR: Rural region
FCV: Fuel cell vehicles	PJ: Petajoule
FFV: Flex-fuel vehicle	SEER: Seasonal energy efficiency ratio
FT: Fischer-Tropsch process	SFH: Single-family housing
GGE: Gallon of gasoline equivalent (energy basis)	SMR: Steam methane reforming
GHG: Greenhouse gas	t/d: tonnes per day
GSP: Gross state product	tCO <sub>2</sub> : tonne of CO <sub>2</sub>
GT-MHR: Gas turbine-modular helium reactor	TOU: Time-of-use
GWh: Gigawatt- hour	TWh: Terawatt-hour
GWP: Global warming potential	VMT: Vehicle miles traveled
H <sub>2</sub> : Hydrogen	ZEV: Zero emission vehicles
HDD: Heating degree days	
HDV: Heavy-duty vehicle	
HHV: Higher Heating Value	
HSPF: Heating seasonal performance factor	
HWP: Harvested wood product	

## 1. INTRODUCTION

In 2005 and 2006, California took several initial steps to address the threat posed by climate change. First, Governor Schwarzenegger issued Executive Order S-3-05, which declared an aspirational goal for California to reduce its greenhouse gas (GHG) emissions to 80% below the 1990 level by 2050. Then, in 2006 Assembly Bill 32 (AB32), the “Global Warming Solutions Act” became law, setting a binding target that GHG emissions be brought back down to the 1990 level by 2020. AB32 included a requirement that specific plans were to be developed as to how the state might achieve the 2020 goal. The AB32 scoping plan (CARB 2009) provides a number of recommended actions to reduce emissions from a wide variety of sources and sectors and provides an important roadmap for achieving the near-term target. These policy measures include market-based mechanisms such as cap-and-trade and a low-carbon fuel standard, and technology-specific standards and regulations including vehicle efficiency standards (commonly known as the Pavley standards), energy efficiency measures, a renewable portfolio standard (33% renewable electricity by 2020), truck and tire standards, etc. In contrast, the long-term 80% goal was set based on the anthropogenic emission rates needed in all industrialized countries to help stabilize atmospheric GHG concentrations at levels that would avoid dangerous climate change (IPCC 2007). There exists significant uncertainty as to how these deep emission cuts would be achieved, what they would cost, and what policy measures would be needed.

California’s population is projected to grow to 50 million by 2050 (California Department of Finance 2013), a 34% gain from the 2010 level. This will be accompanied by continuous growth in demand for energy to provide services across all sectors of the economy, from transportation, heating, cooling, lighting, refrigeration, to industrial activities. Meeting these demands also presents tremendous challenges in managing consumers’ spending on energy costs and consumer technologies from vehicles to light bulbs; business investments on boilers, heat and power generation, infrastructure, etc. How we combine the objectives of reducing GHG emissions to mitigate the impacts of climate change, and meeting the growing demand for energy services at costs that are manageable and acceptable to the consumers and the industry is one of the biggest challenges that the state is facing today.

This report describes the CA-TIMES, a 4E (Energy-Engineering-Environmental-Economic) model, that explores the potential of various technology and policy options for reducing GHG emissions while meeting the future energy demand in California by 2050. It is important to recognize that CA-TIMES is a cost-optimization or utility maximization (with elastic demand) model, which uses scenarios to describe views of the future and how to achieve policy objectives by either *minimizing costs* that are considered in the model (which typically include capital, fixed and variable O&M costs for energy supply, conversion, transport and end-use technologies) or *utility maximization* (which maximizes producer and consumer surplus) when solving with elastic demand. The model allows the consideration of consumer’s risk aversion toward uncertainties to new technologies, but does not take into account social or noneconomic factors (such as imperfect markets) that often create barriers for least-cost technology adoption. Therefore the outcomes of the model should not be considered as projections, but rather a roadmap to achieve policy objectives by minimizing the total system costs or total system utilities within a set of assumptions and constraints. Unlike a general equilibrium model, the model does not consider constraints on capital and labor, nor the feedback of GDP due to increased costs of mitigation (Loulou and Lavigne 1996).

We describe the general literature of energy modeling for energy and climate policy analysis, and California’s energy systems and GHG emissions in Section 1. Section 2 describes the model structure and modeling equations for solving the model via optimization (minimizing cost) vs. partial equilibrium (maximizing welfare) and how the model incorporates policies and consumer behaviors. The supply sector, which includes resource extraction, supply, and fuel production, is described in Section 3. Section 4 describes the demand sectors including transportation, residential, commercial, and non-energy sectors. In Section 5, we present scenarios and results, and discuss the implications in Section 6. In Section 7, we

present several innovative stand-alone models that use TIMES algorithm (cost-minimization) to explore more advanced and complex modeling approaches. These stand-alone models are cutting edge research that demonstrates potential techniques to improve existing models, but are currently too computationally burdensome to be included in the core CA-TIMES model. We conclude with our key observations and future research directions in Section 8.

## 1.1 Background and Motivation

Over the past several years, a variety of scenario analyses and energy modeling tools have been used to envision how deep cuts in GHG emissions can be made in the long-term, using commercial or near-commercial low-carbon and advanced technologies and fuels (IPCC 2007, GEA 2012, IEA 2012). These studies have shown that protecting the global climate will necessitate dramatic changes in the way societies produce and consume energy. A robust finding of these studies is that the transport and electric sectors must be significantly decarbonized if deep economy-wide emissions reduction targets are to be achieved.

Several recent studies have looked at how California can achieve significant GHG emission reductions, on the order of 80 percent below 1990 level, as established in Executive Order S-3-05. For example, McCollum and Yang (2009) looked at snapshots of 2050 to see what combination of travel demand reductions, efficient vehicle technologies, and low-carbon alternative fuels could be used to meet an 80% reduction within the transportation sector. Similarly, the California Air Resources Board (CARB) examined how an 80% reduction could be achieved exclusively in the light-duty vehicle sector, primarily using zero-emission vehicles (ZEVs) to achieve the target (CARB 2009). Several recent studies look at multi-sectors in California, and how California might achieve deep GHG reduction between 2030-2050 from a pure technology perspective (CCST 2011, Long, John et al. 2011, CCST 2012, McCollum, Yang et al. 2012, Nelson, Johnston et al. 2012, Williams, DeBenedictis et al. 2012, Greenblatt 2013, Wei, Nelson et al. 2013). However, all the above mentioned scenario studies have some important limitations: they either do not take costs into consideration or lack a systems modeling approach. Meaning that they fail to explicitly assess costs, the interactive effects of policies or markets, or adequately address critical questions relating to the optimal allocation of resources: both physical and financial.

While macroeconomic models such as E-DRAM<sup>1</sup> or Berkeley Energy and Resources (BEAR) model<sup>2</sup>, two general equilibrium models of the California economy, can partially fill this void by capturing important system dynamics in the larger economy, these models lack the rich technological detail of bottom-up engineering economic approaches. Nevertheless, several macroeconomic models have been extensively used to assess the economic costs associated with meeting AB32 goals in 2020 as laid out by the Scoping Plan and to inform California's near-term climate policy discussions. The Energy2020 model has subsequently been used to provide more detailed energy system representation; the model links to E-DRAM and attempts to understand the energy supply and demand technologies that could be utilized to meet the AB32 goal in 2020 (ICF 2010). For longer-term analyses, as California continues to move forward with a broad spectrum of carbon emissions reduction policies, there is a strong need for new tools that are able to provide strategic guidance to decision makers and to help them envision the multiple paths to a low-carbon society. Table 1.1 provides a list of energy-economic-environment models calibrated for California, modeling types and the type of questions it can address based on the construction of these models. The CA-TIMES model attempts to fill an important gap in the California energy policy space by offering a transparent and flexible analysis platform that can address the specific conditions that exist within the state.

---

<sup>1</sup> [http://www.arb.ca.gov/cc/scopingplan/document/economic\\_appendix2.pdf](http://www.arb.ca.gov/cc/scopingplan/document/economic_appendix2.pdf)

<sup>2</sup> [http://are.berkeley.edu/~dwrh/CERES\\_Web/Docs/BEAR\\_Tech\\_2.0.pdf](http://are.berkeley.edu/~dwrh/CERES_Web/Docs/BEAR_Tech_2.0.pdf)

**Table 1.1. California statewide energy-economic-environment models that have been applied to analyze state energy and climate policies.**

Model Name	Modeling Teams	Modeling Type	Type of Questions That It Can Address
E-DRAM*	UC Berkeley	Computable general equilibrium (CGE) model	Detailed emission and energy use patterns. Change in output, prices, employment, personal income and consumer spending
Berkeley Energy and Resources (BEAR) model	UC Berkeley	Computable general equilibrium (CGE) model	Detailed emission and energy use patterns. Change in output, prices, employment, personal income and consumer spending
CA-TIMES	UC Davis	Economic optimization (cost minimization or utility maximization) model	Energy use and technology adoption driven by economics of resources and technology costs for both supply and demand across all sectors
SWITCH	UC Berkeley and LBNL	Detailed electric sector optimization (cost minimization) model soft linked with other energy models	Electric sector capacity expansion, generation/reliability trade-offs, optimization of the generation and storage mix, electricity prices, demands. SWITCH models for the rest of the energy system including electrified transportation
Energy 2020*	ICF	Simulation model based on qualitative choice theory (maximize utility within constraints of imperfect market)	Energy use and technology adoption. When linked to macro-economic model provides economic changes resulting from policies (GDP, employment, personal disposable income, etc.)
The California Greenhouse Gas Inventory Spreadsheet (GHGIS) Model	Lawrence Berkeley National Laboratory	Scenario-based non-economic models	Explore the extent of individual policies and the impact of combinations of state policies on state greenhouse gas (GHG) and regional criteria pollutant emissions
IEPR	CEC	Scenario-based. Combination of models for the different parts of the energy system.	Energy use, technology adoption. The CEC suite of models are being used only up to 2030
AB32 Scoping Plan	CARB	Scenario-based non-economic models	Energy use, technology adoption, policy strategies
Vision Project	CARB	Scenario-based non-economic models	Transportation energy use, technology adoption, policy strategies
E3*	E3	Scenario-based non-economic models	Electricity and natural gas utility sectors only. Analyze how climate policies affect utility costs and consumers' electricity bills

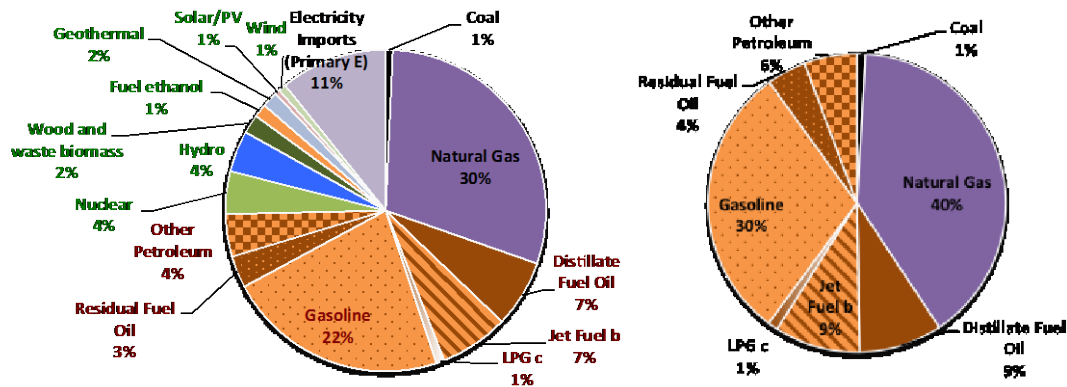
\* Model that participated in the last Scoping Plan to 2020.

## 1.2 Current Snapshot of California Energy Use and GHG Emissions

California has the highest population among all states, and ranks 16<sup>th</sup> in personal income. Although California's per capita energy use, energy intensity (thousand Btu per dollar of GDP) and per capita GHG emissions are among the lowest 10% among all US states, the total GHG emission rank is the second highest, about 50% of the highest emitting state Texas (EIA 2013). California's petroleum and electricity prices are well above the U.S. average, and its electricity generation mix has a lower carbon intensity than the U.S. average. Historically, California has had some of the most aggressive energy and environmental policies in the country, including policies addressing GHG and air quality emissions, and vehicle and building energy efficiency standards.

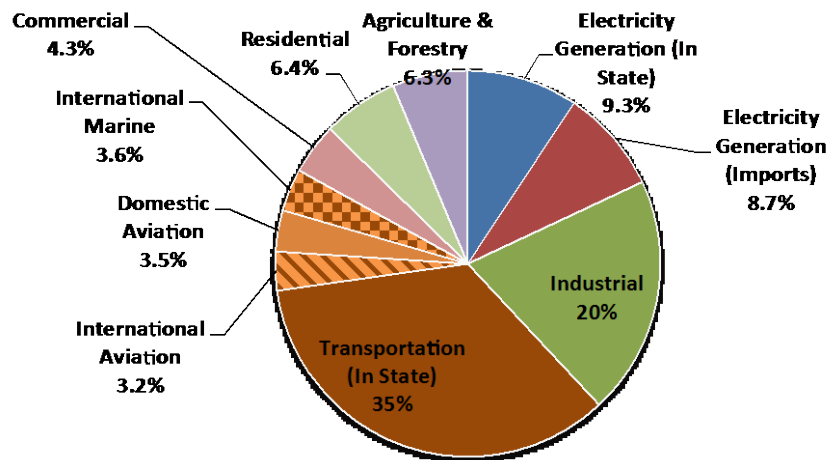


Figure 1.1 (left) shows energy consumption (including energy losses associated with electricity generation, transmission, and distribution) in the state, for a total of 7846 trillion Btu in 2010. Transportation alone contributes to 46% of total primary energy consumption, while the demand for electricity and natural gas (which are consumed in end use sectors including industrial, residential, commercial and agricultural sectors) constitute the majority of the rest. Transportation petroleum fuel use constitutes about 60% of total fossil energy use (Figure 1.1, right).



**Figure 1.1. Total energy consumption (left) and fossil energy (right) (including energy losses associated with electric generation, transmission, and distribution) for California, 2010.** Total energy consumption in 2010 is 7846 Trillion Btu (left), of which 85% comes from fossil energy (right, 5854 trillion Btu). Source: EIA (2013).

The single largest contributor to emissions in California is the transportation sector, accounting for 45% of total emissions (CARB 2013)(Figure 1.2) (35% comes from in-state emissions, while the other 10% (51.4 million metric tonnes CO<sub>2</sub> equivalent ) comes from domestic and international aviation and international marine bunker fuel use. These emissions are reported but not included in the state emission inventory). Electricity generation (in state and imports) accounts for only about 18% of total emissions, while industrial (20%), residential (6.4%) and commercial (4.3%) sectors make up the rest (CARB 2013).



**Figure 1.2. State-level GHG emissions in 2010.** Source: (CARB 2013). Total emissions are 449.37 million metric tonnes CO<sub>2</sub> equivalent and 500.74 million metric tonnes CO<sub>2</sub> equivalent when domestic and international aviation and international marine bunker fuel use are included.

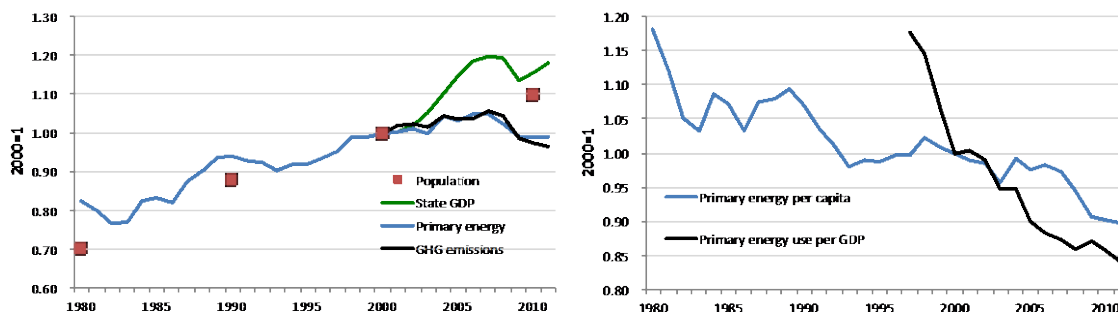
The relatively small contribution to emissions from California’s electricity sector is important to recognize, as electric generation has been identified in a number of studies and contexts as one of the least costly sectors to decarbonize (Yeh, Farrell et al. 2008, IEA 2012, McCollum, Yang et al. 2012). The large

proportion of emissions from the production and use of fuels (e.g., natural gas and liquid transportation fuels) means that meeting an 80% reduction in emissions requires improving efficiency of fuel use and significantly shifting the final energy consumption to low-carbon fuels and electricity, both of which represent some potentially challenging propositions (CCST 2011).

### 1.3 Drivers for Future Energy Demands and Emissions

California’s population is projected to grow to 50.3 million by 2050 (California Department of Finance 2013), a 34% gain from the 2010 level. This will be accompanied by continuous growth in demand for energy to provide services across all sectors of the economy, from transportation, heating, cooling, lighting, refrigeration, to industrial activities. This projection of population growth differs significantly from recent projections of 59.5 million (from 2007) and 54.8 million (from 2004) in 2050. Thus, projections of energy demand, service demands and emissions made in the last few years and policy analyses that relied on these projections may differ significantly in their results.

In the past two decades, California’s primary energy use and GHG emissions have grown slower than population growth and GDP increase (Figure 1.3) due to policies such as energy efficiency measures for vehicles and for consumer appliances. Energy efficiency improvements reduce energy use while delivering the same energy service (e.g., heating, cooling, lighting, vehicle miles). Thus our model builds on a more robust estimate, i.e., energy service demand as opposed to primary or final energy demand, that allows for endogenous technological changes to take place in spite of demand growth. Changes in service demand via structural changes, such as denser cities that reduce demand for vehicle travels or shifting from heavy industry to service industry, cannot be modeled endogenously in our model but can be modeled as separate scenarios. Making a clear distinction of drivers of changes, and how policy levers can affect these drivers, is essential for understanding our model results and analyses.



**Figure 1.3. Historical trend of California population, GDP (in constant dollar), primary energy use and GHG emissions (left) and energy use per capita and per GDP. Source: (CA DOF 2013, CARB 2013).**

### 1.4 Study Goals

The purpose of this particular study – and the CA-TIMES model in general – is to provide strategic guidance to California decision makers. We aim to produce policy insights, for example, on how economic drivers (such as technology and resource cost considerations, and competition among technologies) and policies (such as an emissions trading scheme, renewable portfolio standard for electricity, biofuels mandates, and vehicle tailpipe emissions standards) might affect future decisions on the investment of future energy technologies and utilization of resources under various scenarios. Our overall intent is to develop an improved understanding of the structure, operation, and cost of the future California energy system under different sets of assumptions about future population, GDP, demand growth, technology availability, and energy and environmental policies. Specifically, we analyze the optimized technology options and trajectories for meeting California’s 80% reduction goal for 2050.

With an eye toward policy design and formulation, the insights from this modeling exercise are intended to provide useful information for California policymakers as they seek to understand which energy sectors and technologies can (or should, under an optimization framework) play a role in both near- and long-term reductions in GHG emissions, considering the state’s specific and unique context. At the same time, because of the CA-TIMES model’s rich characterization of the energy supply sectors of the economy (including fuel supplies (e.g., hydrogen, biofuels) and electric generation), and energy demand sectors (including transportation, residential, commercial, industrial and agriculture<sup>3</sup>), we can explore the interactions within and across the supply and demand sectors in response to policies. For example, policies to encourage bio-based renewable electric generation (e.g., electricity generation from wood or biogas) and hydrogen production will reduce the availability of biomass for biofuels in the transportation sector.

The results from the modeling exercise can be applicable to the much larger community of energy and environmental policy analysts and modelers outside of California, particularly those focusing on the challenges of – and solutions to – rapid growth in decarbonizing the economy.

---

<sup>3</sup> The industrial and agricultural sectors are not modeled with the same level of technological detail as the other sectors listed, but are handled more simply with scenario-based energy demands.

## 2. MODEL STRUCTURE AND MODELING APPROACHES

The California TIMES (CA-TIMES) model is an integrated energy-engineering-environmental-economic (4E) systems model focusing on the California energy system. The model is both rich in technological detail and covers all sectors of the California energy economy, including energy supply (energy resources and feedstocks (oil, gas, and biomass), fuel production/conversion, fuel imports/exports, electricity production, and fuel delivery), and demand (i.e., residential, commercial, industrial, transportation, and agricultural end-use sectors). Figure 2.1 presents a highly simplified schematic of the reference energy system (RES) of the CA-TIMES model. Demands for energy services in transportation, residential and commercial sectors drive the demand for end-use technologies and energy carriers, the latter of which must be supplied by fuel and electric generation plants powered by a range of fossil and renewable energy resources. Demands for industrial and non-energy sectors are modeled simplistically at the fuels level; therefore no end-use technology details are represented in these two sectors.

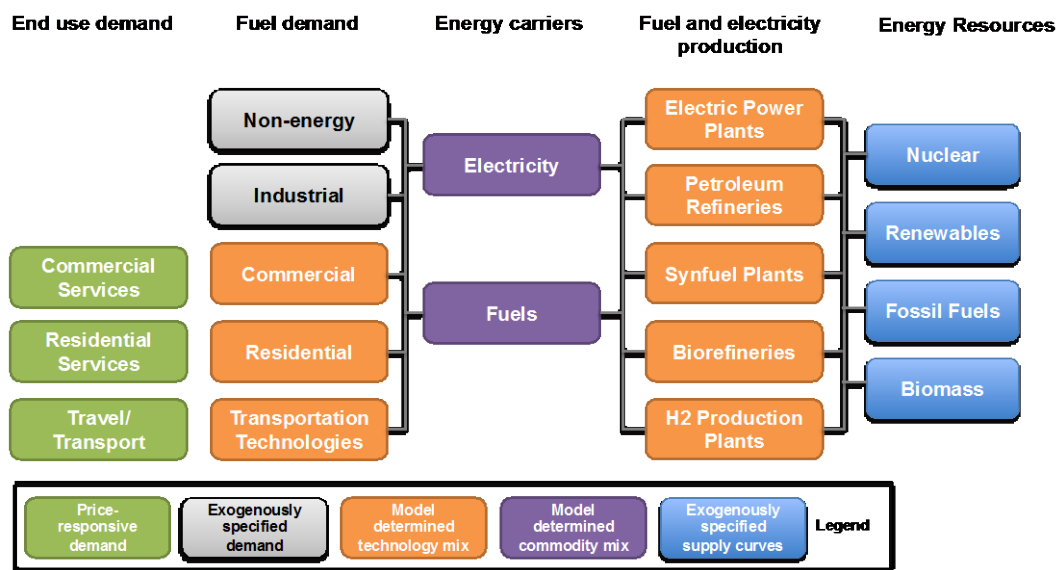


Figure 2.1. Schematic diagram of CA-TIMES model (version 1.5).

Developing and running CA-TIMES requires a substantial quantity of data inputs, including cost, efficiency and other assumptions for individual technologies in all time periods up to 2055. CA-TIMES model development is an ongoing process that will span several years. The model description and analysis described in this report refers to the first public version of the model, CA-TIMES v1.5, as opposed to the first version of the model (CA-TIMES v1.0) of which results were published without the database (McCollum, Yang et al. 2012) due to the ongoing nature of research efforts. The CA-TIMES v1.5 is updated and re-calibrated to the year 2010 as the base year. All the costs represented in the model now are in 2010 dollars. Below we briefly describe the model structure, with more detailed descriptions in the following sections and Chapters.

**Demand.** Energy service demands (e.g., lighting, heating, cooling, and vehicle miles traveled) are estimated exogenously based on demand drivers such as population growth, GDP, # of housing units, and square footage of commercial space for the residential and commercial sectors. The industrial and agricultural demands are treated fairly simply by projecting the future fuel usage based on historical trends. We also run certain sets of scenarios which demands are endogenous in responsive to own price changes by specifying the price elasticities of service demands. This will be explained further in Section 2.2.

**Supply.** The supplies for primary energy are represented as *supply curves*. In some cases (e.g. oil and gas from outside of California), the supply curves are exogenous projections from the Energy Information Administration based on the belief that demand level changes in California will not affect fuel prices in the US and rest of the world. Some are represented as step functions of annual potential (e.g. maximum available biomass at a given price, or available wind or hydro potentials). There are also trading possibilities where the amount and prices of the traded commodities are determined endogenously (within any imposed limits) or exogenously (for a pre-specified price and quantity).

**Policy.** The all-encompassing nature of TIMES model allows a wide-range of policies to be represented in the model. This can range from explicit fuel taxes, technology subsidies, or carbon taxes that can be added directly to a technology, or products (e.g. finished fuels or emissions) to more elaborate policy measures such as renewable portfolio standards (RPS), energy efficiency standard for appliances and vehicles, or an emission cap that can be represented as constraints in the market share, technology penetration level, or total emission levels.

**Technology.** In TIMES, the transformation of primary resources into energy services are represented by a series of technical and economic parameters for technologies (or processes) that transform energy resources into fuels, materials, energy services, and emissions. The quality of a TIMES model rests on a rich, well developed set of technologies and technology assumptions (in terms of costs, efficiency, availability, etc.), both current and future, for the model to make decisions in response to both exogenous and endogenous changes in drivers, scenarios, policies, etc.

## 2.1 Primary Modeling Approach: Optimization

CA-TIMES is built upon the MARKAL-TIMES optimization framework, which is used by dozens of research groups and energy agencies throughout the world (Loulou and Labriet 2008). The objective of the model is to meet future fixed energy service demands at minimum global cost (i.e., the minimum total discounted net present value (NPV) of all costs accounted for in the model) subject to a large set of technical, social and policy constraints. CA-TIMES identifies the most cost-effective technology pathways and resources options that will enable the state to transition to deep reductions in GHG emissions. Such an optimization approach can be described as representing a single decision maker with “perfect foresight”, as the model possesses full information about all future demands, technologies and resources and makes the least-cost investment and operating decisions throughout the modeling years in order to minimize the present value of all system costs.

$$NPV = \sum_{y \in YEARS} (1 + d_y)^{REFYR-y} (ANNCOST(y) + FIXCOST(y) + VARCOST(y) + ELASCOST(y) + \dots)$$

(Equation 2.1)

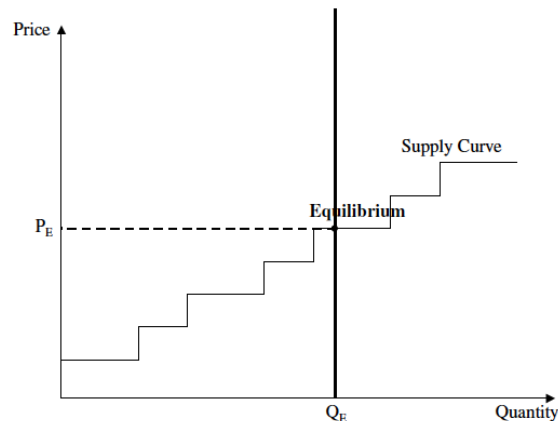
where,

NPV	= net present value of the total system costs;
$d_y$	= general discount rate;
REFYR	= reference year for discounting;
YEARS	= set of years for which there are costs, including all years in the horizon;
ANNCOST	= annual costs of investment. Each yearly payment is equal to a fraction, i.e., the CRF, of the total investment cost, INVCOST (CRF = Capital Recovery Factor, see Section 2.3 Hurdle Rate for more discussion on CRF);
FIXCOST	= fixed annual costs;
VARCOST	= variable annual costs;

ELASCOST = cost of demand reduction, the value is 0 when the model runs only with cost minimization (without elastic demand)

Additional costs terms such as investment taxes and subsidies, decommission costs, taxes and subsidies attached to fixed annual costs, salvage values of investments, etc. can also be added when appropriate. More detailed documentation of the model concepts and theory can be found at Loulou, Remne et al. (2005).

For most cases, the objective of the CA-TIMES model is simply the minimization of the total cost of meeting exogenously specified level of energy service, as illustrated in Figure 2.2. We also run scenarios of alternative demand scenarios given structural changes (e.g., reduced travel demands due to the success of land use policies or other demographic changes), but these changes are exogenous that do not respond to price changes.



**Figure 2.2. Equilibrium when an energy service demand ( $Q_E$ ) is fixed.** Source: (Loulou, Remne et al. 2005).

The decision variables in the model are technology investment, retirement, operation (activity levels and storage), primary energy supply, and energy trade decisions (i.e. level of imports). The key advantage of the CA-TIMES model is that it is a vertically integrated model of the entire extended energy system within California. For example, if there is an increase in residential electricity demand relative to the reference scenario (perhaps due to a shift from natural gas furnaces to electric heat pumps), either existing electricity generation must be used more intensively or new generation must be installed. If the demand has a distinct time profile, then the increased generation must also match the time profile of the increased demand. The choice by the model of the electricity generation equipment (type and fuel) is based on the analysis of the characteristics of alternative generation technologies, on the economics of the energy supply, and on environmental criteria if there is a constraint on emissions (Loulou, Remne et al. 2005).

In this respect, CA-TIMES (like all models) represents a simplification of reality. Also like all models, it has many caveats and the results of the model should be interpreted with great caution.

#### **Modeling simplifications and caveats:**

- There is a single global decision maker in CA-TIMES vs. millions of individual decision makers in reality, (In Chapter 8, we discuss a technique to incorporate consumer heterogeneity into the model.)
- Decision making with perfect foresight and no uncertainty (deterministic).
- Decisions are driven by economics, and assume decision-makers make rational decisions based on monetary tradeoffs (investment and operating costs) and the model uses constraints and other approaches to account for behaviors such as consumers'/producers' attitudes toward technology risks, uncertainties of future costs (including technology costs and fuel costs) and policies, and

social aspects of decision making (e.g. non-competitive markets) that cannot be captured based on costs alone.

- Exogenous assumptions about technology availability and cost changes over time and these assumptions play a very important role in the model solutions. Empirical evidence from the literature on technology learning suggests previous investments stimulate cost reductions in the long run, a relationship typically captured in the “experience curve” or “learning curve” (Yeh and Rubin 2012). Though the model could simulate endogenous technological change (ETL) via the implementation of *learning curves*, such model advancement is not implemented in this version of the model. In CA-TIMES we assumed exogenous cost reduction rates regardless of scenarios and policies.
- No feedback between the energy sector and state GDP. Macroeconomic variables such as state production, consumption, and savings can be affected by policies such as energy and environmental policies. CA-TIMES relies on exogenous projections of state GDP. If other studies suggest that there is an observable linkage with state GDP, this can be handled as scenarios rather than endogenously captured in the model.

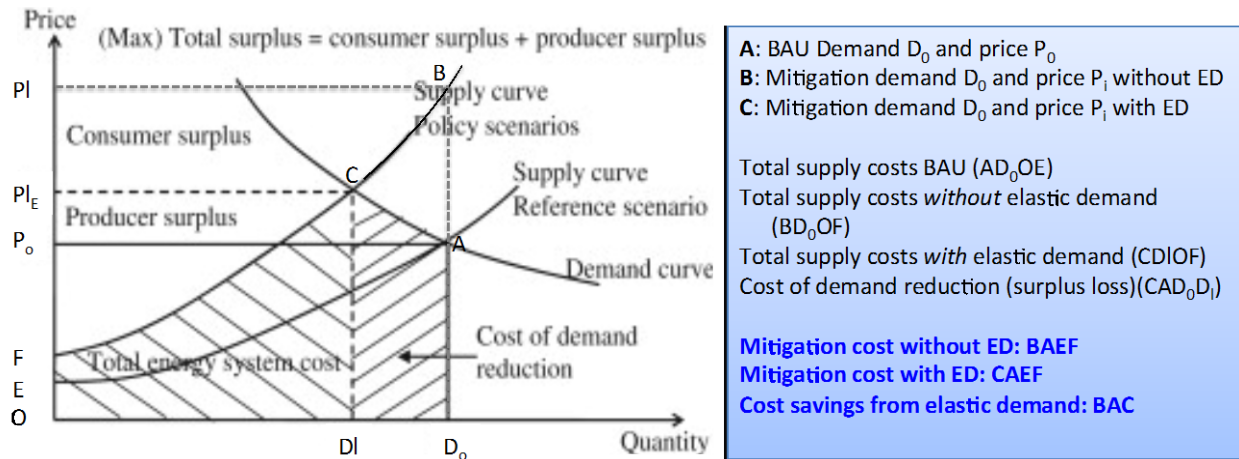
## 2.2 Alternative Modeling Approach: Partial Equilibrium with Elastic Demand (ED)

In most cases, we run the model with exogenously specified service demands, i.e., the specified energy services (e.g., lighting, heating, cooling, and vehicle miles traveled) are model inputs, must be met fully in each model year, and they are not responsive to price changes. In reality, consumers do respond to price changes: they travel less and adjust their thermostats when prices increase. When demands are lower, the supply costs fall. Therefore, we also run a few scenarios when demand for energy services is responsive to price changes. When the demand is endogenous, CA-TIMES computes a partial equilibrium on energy markets. This means that prices of providing the energy service will match exactly the amounts that the consumers are willing to purchase. This equilibrium feature is present at every stage of the energy system: primary energy forms, secondary energy forms, and energy services.

When the demands respond to supply price changes, instead of minimizing total system costs, the supply-demand equilibrium model maximizes the total surplus, defined as the sum of suppliers and consumers surpluses, as shown in Figure 2.3. Following the Equivalence Theorem, maximizing total surplus (consumer surplus + producer surplus) is also the same as minimizing the total discounted system cost and the cost of demand reduction (Loulou and Lavigne 1996), also shown in Figure 2.3. The demand curve shown in Figure 2.3 is represented by:

$$D/D_0 = (P/P_0)^{\text{Elasticity}} \quad (\text{Equation 2.2})$$

Where  $(D_0, P_0)$  is a reference pair of demand and price values for that energy service for a given time period, and *Elasticity* is the (negative) own price elasticity of that energy service demand.



**Figure 2.3. Illustration of supply-demand equilibrium with elastic demand.** Source: modified based on Kesicki and Anandarajah (2011).

Instead of investing in more expensive technologies to meet a fixed demand (point B), consumers also have the options of reducing service demand (point C), resulting in lower energy costs ( $P_{1E}$  as opposed to  $P_1$ ) and lower energy supply costs (the area surrounded by  $CDIOF$  as opposed to the area surrounded by  $BD_0OF$ ). Given the value of elasticity is always smaller than or equal to zero, the sum of total energy system costs *with* elastic demand (the area surrounded by  $CDIOF$ ) plus the cost of demand reduction (loss of consumer welfare, the area surrounded by  $AD_0DIC$  in Figure 2.3, which is  $ELASCOST$  in Equation 1) will always be smaller than the total energy system costs without elastic demand (the area surrounded by  $BD_0OF$ ). This means that the compliance costs that we calculate for meeting GHG policy targets, plus the loss of consumer surplus will always be smaller with elastic demand compared with the estimated compliance costs without ED. The mitigation costs without elastic demand is the area  $BAEF$ , and  $CAEF$  with elastic demand. Thus the net cost savings with elastic demand is the area  $BAC$  compared mitigation without elastic demand (most of deep GHG scenarios reported in this report).

The model optimizes the system configuration by maximizing system surplus (for both producers and consumers). Thus, when there is a reduction in demand, the cost of producing energy services can decline, but there is also a concurrent reduction in the consumer surplus, a non-economic cost associated with loss of consumer welfare resulting from the reduction in energy service (i.e., the loss in consumer well-being associated with traveling fewer miles by car). These costs are calculated in the model, but since they are not tangible, there is a question as to whether they should be included in the mitigation cost calculation. If the utility cost is excluded since it is not a tangible investment costs, then the calculated abatement costs may be lower than their actual “cost” to the society since reducing demand for energy services does impact consumer utility.

Another separate issue that is part of our ongoing research effort is that the cost savings estimated from this version of the model may be overestimated due to how “savings” are specified in the model. When people reduce energy services (e.g., less travel, less cooling in the summer, or less heating in the winter) due to higher energy prices, they save on fuel costs but overall they may still buy roughly the same number of cars, heaters, or air conditioners, but simply use them less. We have developed two versions of elasticity (described in later sections) in which consumers’ demand response can take different forms. The first is where demand reduction leads to a proportional reduction in investment in new equipment. To the extent that consumers do not actually reduce their purchase of this equipment, this scenario’s results will overestimate cost savings associated with demand elasticity. Another form is where demand reduction occurs but does not result in any reduction in the quantity of appliances and equipment used to meet demand. These two cases are treated as bounding cases for the analysis of demand reduction as a GHG mitigation option.



### 2.3 User Constraints and Other Techniques to Approximate Markets and Behaviors

It is often the case that in order to approximate imperfect market or non-market behaviors, such as those caveats that we mentioned in the previous section, we use a number of “modeling tricks” to constrain the model. These modeling techniques, typically based on the intuition of modelers or historical observations, are briefly described below.

#### Constraints on technology growth rate

Due to the optimization nature of the model, new investments in least-cost technology tend to constitute 100% market share of the new technology stock if there are no other user constraints. This is often referred to as the “all-or-nothing” behavior of optimization models. Therefore a typical practice is to apply growth rate constraints in controlling the penetration of technologies over time. A growth constraint may, for example, express that the capacity increase between two periods is limited by an annual growth rate. This is intended to approximate (in a simplistic and exogenous fashion) real world constraints such as the time it takes to expand plant capacity, build enough new production plants or infrastructure. Or it can be due to heterogeneity of consumers where it takes new technologies significant time to capture the entire market. These constraints can be binding or non-binding. When binding, these constraints play an important role in determining the outcomes of the scenarios. Therefore, the assumptions of growth rate constraints are documented in Appendixes B and C and alternative assumptions of growth rates constraints are explored in the scenario analysis.

#### Hurdle Rate

In CA-TIMES model, investments in technology are based minimizing costs: the technologies with the lowest investment and operating costs are selected to meet end-use demand. However, there is a wide-recognition that “efficiency gaps” exist and in certain cases, consumers do not choose the option with the lowest levelized cost; instead, consumers behave as if they have high discount rates (Greene, German et al. 2009, Greene 2011, Gillingham and Palmer 2013). A variety of explanations, such as consumer preferences, consumer heterogeneity, hidden costs, risk aversion to uncertainty, and information gaps have all been offered as possible explanation. We approximate this behavior by assigning a higher technology-specific discount rate to each consumer technology based on literature values, (documented in Appendixes B and C).

In the TIMES modeling framework, investments in technology result in a stream of annual payments spread over the economic life of the technology (ELIFE), similar to financing the purchase with a loan. Each yearly payment is equal to a fraction, CRF, of the investment cost (CRF = Capital Recovery Factor). Note that if the technology discount rate is equal to the general discount rate (which is set at 4% in the model), then the present value of a stream of ELIFE yearly payments is equivalent to a single payment of the whole investment cost (Loulou, Remne et al. 2005). If however the technology’s discount rate is chosen different from the general one (usually higher), then the stream of payments has a different present value than the lump sum. Note that:

$$CRF = \frac{1 - \frac{1}{1+r}}{1 - (\frac{1}{1+r})^{ELIFE}} \quad (\text{Equation 2.3})$$

Where  $r$  = technology specific discount rate (often referred to as the hurdle rate), and ELIFE is the economic lifetime of technology.

Table 2.1 illustrates the relation between hurdle rate, CRF, annual payment, and net present value of the technology. Using an example of a technology with an investment cost of \$1 million and an economic life of 15 years, based on different technology hurdle rates and a general discount rate of 4%, the annual payment and net present value of investment is calculated using the following formulas:

$$\text{Annual payment} = \text{CRF} \times \text{Investment cost} \quad (\text{Equation 2.4})$$

$$\text{Perceived net present value by customer} = \sum_{i=1}^{\text{ELIFE}} \frac{\text{Annual payment}}{(1+gr)^i} \quad (\text{Equation 2.5})$$

Where g = general discount rate

**Table 2.1. An example of technology-specific discount rate, CRF, the annual payment and perceived net present value by consumers** (assuming ELIFE = 15, investment cost = 1 M\$).

Technology specific discount rate (hurdle rate), r	0.04	0.08	0.12	0.16	0.2	0.24	0.28	0.32
Capital recovery factor, CRF	0.09	0.11	0.13	0.15	0.18	0.20	0.22	0.25
Annual payment (M\$)	0.09	0.11	0.13	0.15	0.18	0.20	0.22	0.25
Perceived net present value (M\$) by consumers	1.00	1.22	1.45	1.67	2	2.22	2.45	2.78

It can be seen in Table 2.1 that if the technology hurdle is equal to the general discount rate, the net present value perceived by consumers is equal to the actual investment cost (1 million dollars). With the increase of technology hurdle rate, the perceived upfront cost by consumers goes up to around 2.78 million dollar (with a hurdle rate of 32%). Since fixed and operating costs (which include fuel costs) are discounted based on the general discount rate (4%), the higher values of  $r$ , the more expensive the upfront investment costs compared with fuel savings, the lower the expected level of adoption and the greater the “efficiency gap”.

While this modeling technique is a good approximation of consumer behaviors resulting in simulated purchase decisions of technology adoption by consumers, these costs (through CRF multiplier) are not the actual costs that consumers pay nor are they real costs to the economy. Therefore, when calculating the system costs, including the abatement costs of policies, the real discount rate is used instead of hurdle rate. In other words, technology hurdle rates are only used to simulate the penetration of consumer technologies but not the actual costs of technology adoption (and carbon mitigation).

### 3. ENERGY SUPPLY

The energy and fuel supply sector in CA-TIMES covers the extraction of all primary energy resources as well as the conversion and transport of processed fuels (i.e., secondary and final energy carriers). It is the largest, most complex sector represented within CA-TIMES, encompassing everything within the three rightmost columns of Figure 2.1 except for electric power plants.

The model represents the production of primary energy resources with supply curves of varying complexity. These fuel supplies are discussed in greater detail in the sections below. In CA-TIMES, most primary energy resources are imported into the state and delivered to fuel conversion facilities, such as oil refineries, bio-refineries, synfuel and hydrogen production plants. Most of these plants are assumed to have fixed investment costs and efficiencies that exogenously change over time throughout the modeling period. Often the cost assumptions used in this model do not capture the very high costs of the first few plants, but represent mature technologies that are commercially available. In Chapter 8.1, we explore the spatially optimized hydrogen infrastructure built out over time, but that level of modeling details is not currently represented in CA-TIMES. CA-TIMES also allows for finished fuels (e.g., biofuels, refined petroleum products) to be imported into the state as well. Supply curves are specified for each of these imported commodities. Dozens of fuel transport and delivery technologies are used in CA-TIMES to distribute the various primary and final energy commodities to the fuel conversion and end-use sectors. Along the way, production, transport, and delivery costs are assigned, and upstream emissions are allocated. Figure 3.1 shows the schematic representation of the CA-TIMES model with the sectoral details.

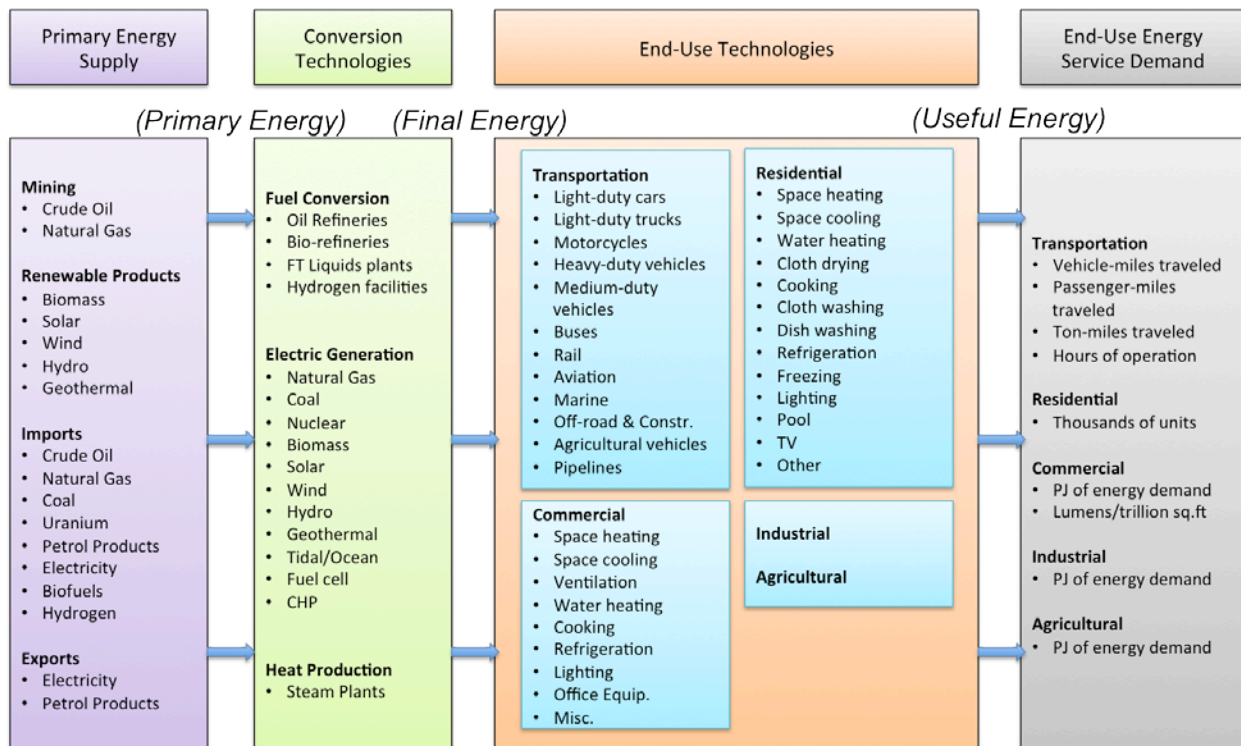
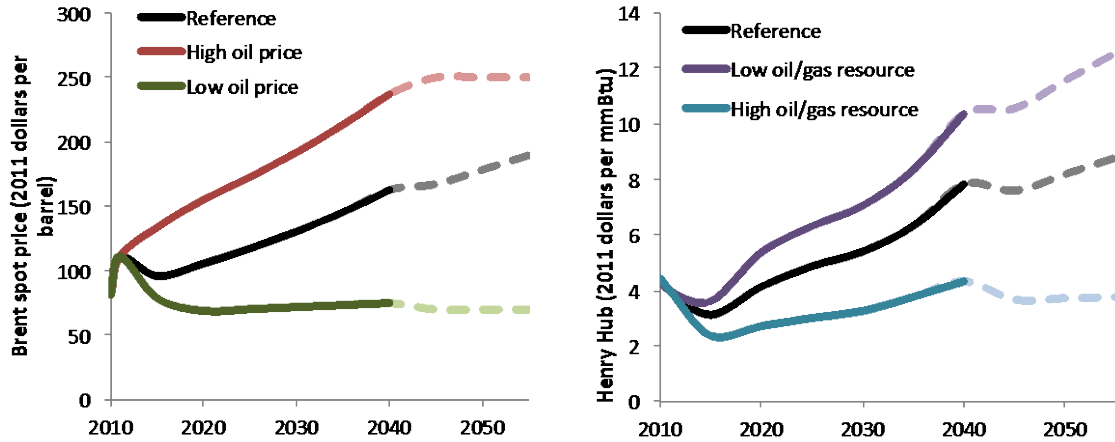


Figure 3.1. Schematic Representation of CA-TIMES Model.

### 3.1 Oil and Natural Gas

#### 3.1.1 Supply curves

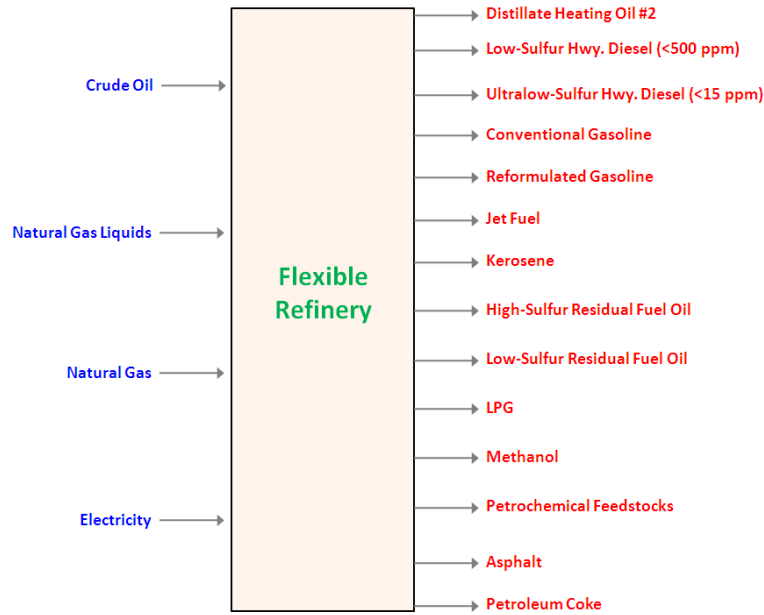
Crude oil and natural gas are treated very simply (exogenous price projections), as California is assumed to be a price-taker for both resources. Figure 3.2 shows price projections of crude oil and fossil natural gas in the reference scenario and high-low price scenarios. The model also allows for imports of finished fuels from outside the state, such as natural gas (via pipeline or LNG), refined petroleum products (e.g., gasoline diesel, jet fuel, kerosene, residual fuel oil, etc.). Natural gas can also be produced from bio-based resources such as bio-methane.



**Figure 3.2. Crude oil (left) and natural gas (right) price projections assumed in CA-TIMES v1.5.** Source: (EIA 2013). Dashed lines represent our own extrapolation from 2040 to 2055.

#### 3.1.2 Oil refineries

The refinery technology in CA-TIMES is able to flexibly produce a range of different petroleum products, taking crude oil, natural gas liquids, natural gas, and electricity as inputs (Figure 3.3). Crude oil and natural gas liquids are feedstock inputs (i.e., their carbon and energy content is converted into the fuel products), while the remaining energy carriers are combusted at the refinery in order to generate energy/heat for the various refining operations. In addition, a small fraction of the input crude oil is also combusted. Hydrogen is produced as an intermediary product/input at the refinery using natural gas steam methane reformation, though this process is not explicitly modeled. The outputs produced at the refinery include distillate heating oil #2, low-sulfur highway diesel (<500 ppm S), ultralow-sulfur highway diesel (<15 ppm S), conventional gasoline, reformulated gasoline, jet fuel, kerosene, high-sulfur residual fuel oil, low-sulfur residual fuel oil, liquefied petroleum gases (LPG), methanol, petrochemical feedstocks, asphalt, and petroleum coke (Figure 3.3).



**Figure 3.3. Simplified schematic of flexible refinery technology in CA-TIMES.**

Reflective of a real-world refinery, the flexible technology in CA-TIMES is constrained from over-producing each fuel product by setting an upper limit on the share of total refinery output that can come from a particular fuel. These fuel product splits are relaxed slightly over time (Table 3.1), and along with refinery efficiencies and resource inputs, they are calibrated to the base-year 2010, using data from the CEC’s Energy Almanac (CEC 2010), the EIA Petroleum Navigator (EIA 2010), and the assumptions to the Petroleum Market Module of the EIA’s NEMS model (EIA 2010). Through a process known as “capacity creep”<sup>4</sup>, the existing stock of California refineries is allowed to expand over time. Estimates of future refinery creep for California refineries have been put at about 0.45% per year according to the CEC (CEC 2010), from 4621 PJ in 2005 to 5784 PJ in 2055. Thus, the state’s refining capacity is able to grow, albeit with a much smaller capital outlay than would be expected if a “greenfield” refinery were to be built on a new site. Such greenfield expansions are also possible in the model through investments in a future refinery technology. Refinery efficiency is kept constant and capacity at 89% at all years.

---

<sup>4</sup> Refinery capacity creep is the term used to describe the cumulative result of many small projects and productivity enhancements that enable a refinery to increase crude oil input over time.

**Table 3.1. Assumptions of refinery inputs and maximum shares of outputs in 2010 and 2055.**

	2010	2055
<b>Input (unit energy input per 1 unit energy output)</b>		
Oil	1.110	
Natural gas	0.028	
Electricity	0.003	
<b>Output (maximum share per 1 unit energy output)</b>		
Distillate-Low Sulfur Highway Diesel (500 ppm)	0.037	0.037
Distillate-Ultralow Sulfur Highway Diesel (15 ppm)	0.165	0.165
Conventional Gasoline	0.058	0.058
Reformulated Gasoline	0.431	0.431
Kerosene-type Jet Fuel	0.166	0.166
Kerosene and Other Refined Products	0.015	0.015
LPG	0.024	0.024
Methanol from	0.010	0.010
Petrochemical Feedstocks	0.052	0.052
High Sulfur Residual Fuel Oil	0.030	0.030
Low Sulfur Residual Fuel Oil	0.030	0.030
Asphalt	0.051	0.051
Petroleum Coke	0.070	0.070

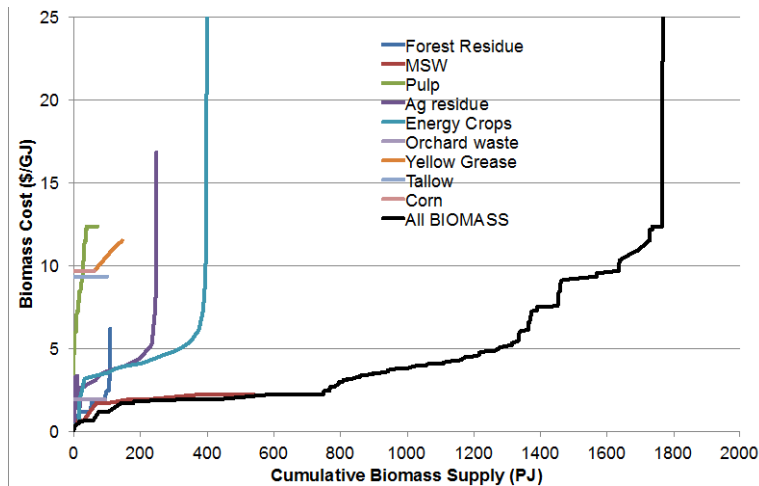
## 3.2 Biomass and Biofuels

### 3.2.1 Biomass supply curves

Biomass supply is represented with supply curves for twelve different feedstock types (e.g., crop and forest wastes, municipal solid waste, energy crops, animal fats and oils), all of which could be produced in California and/or the Western United States with some basic sustainability rules such as slope threshold (forest residue), maximum removal rate (agricultural residue), etc. (Parker, Hart et al. 2010). The supply curves are assessed for every time period. Figure 3.4 shows the biomass supply curves in 2050. The supply curves are taken from Parker (2010), and the feedstocks include forest residues, municipal solid waste or MSW (Mixed<sup>5</sup>, paper, wood, and yard waste), orchard and vineyard waste, pulpwood, agricultural residues (stovers and straws), energy crops (herbaceous), yellow grease, animal tallow, and corn. The model also allows for imports of biofuels from outside the state, including ethanol (made from corn, cellulosic feedstock, grain and sugarcane), bio-diesel, and bio-based synthetic fuels (biogasoline, bio-derived residual fuel oil, bio-derived jet fuel, bio-derived aviation gasoline, bio-derived methanol, and bio-derived synthetic natural gas), produced outside of California and outside of the U.S.

---

<sup>5</sup> Municipal Solid Waste (Mixed) includes the MSW (Dirty) and MSW (Food) categories from Nathan Parker's dissertation work.



**Figure 3.4. Biomass supply curves for California and neighboring states available for bioenergy purposes in California in 2050.**

### 3.2.2 Biorefineries

Several different types of bio-refinery technologies are modeled in CA-TIMES (Table 3.2), though only ethanol and biodiesel are available in the base-year 2010: bio-diesel production facilities consuming yellow grease or animal tallow as feedstocks. Ethanol supply in 2010 is met by imports of corn ethanol from the Midwestern U.S. and sugarcane ethanol from Brazil. After 2010, the model is able to invest in cellulosic ethanol plants (via either the biochemical or thermochemical pathway) and bio-derived residual fuel oil plants (via a pyrolysis bio-oil pathway). These future technologies consume one of nine types of cellulosic feedstock. In addition to producing their liquid fuel products, these bio-refineries also generate a small amount of electricity as a by-product. Feeding this low-carbon electricity to the grid can displace more carbon-intensive sources of electricity, such as natural gas plants. All future bio-refinery technologies are characterized by biomass input efficiencies, investment costs, fixed and variable O&M costs, annual capacity factors, technology-specific hurdle rates, year-to-year limits on capacity growth, and a variety of other information. These technology characterizations largely come from a NREL study (Bainm 2007).

Fischer-Tropsch (FT) coal-biomass poly-generation plants represent yet another category of potential future fuel conversion technologies in CA-TIMES (Table 3.2). These plants consume one of nine types of cellulosic feedstock and then produce some combination of synthetic gasoline, diesel, jet fuel, and/or electricity. Co-firing with coal is an option with certain plant designs. Based on Kreutz et al. (2008), we represent five unique biomass-to-liquid (BTL) and coal/biomass-to-liquid (CBTL) processes that are commercial or near-commercial technologies: BTL-RC-V, BTL-RC-CCS, CBTL-RC-CCS, CBTL-OT-CCS, and CBTL2-OT-CCS. The main differences between them have to do with their varying sizes, biomass-to-coal input ratios, and fuel/electricity product splits; whether CCS is utilized or CO<sub>2</sub> is vented to the atmosphere; and whether a once through (OT) or recycle (RC) approach is used for the initially unconverted synthetic gas (“syngas”). (Note that RC systems maximize FT liquids production, while OT systems allow for more electricity generation at the expense of reduced FT liquids production.) Two of the five plants made available to CA-TIMES consume only biomass (i.e., no coal co-firing); thus, they produce liquid fuel products with zero or significantly negative carbon intensities. For example, the BTL-RC-CCS plant design is an example of a negative emissions technology, since it takes carbon from biomass (which originally pulled CO<sub>2</sub> out of the atmosphere via photosynthesis) and permanently stores it underground (i.e., bioCCS). Further, because the three CBTL plants with coal-biomass co-firing each utilize CCS, they also produce liquid fuel products with relatively attractive carbon intensities, even though coal is used as an input fuel. These carbon intensities are significantly better, or at least no worse, than petroleum-based gasoline. From a technological perspective, carbon capture and storage is

particularly attractive with these FT liquids poly-generation plants because the CO<sub>2</sub> stream that is generated is naturally concentrated – in other words, a nearly pure stream of CO<sub>2</sub> is generated, by default, as a by-product of the FT process, thus the added costs of CO<sub>2</sub> capture are quite low. All future FT BTL/CBTL poly-generation plant technologies in CA-TIMES are characterized by coal and biomass input efficiencies, investment costs, fixed and variable O&M costs, annual capacity factors, technology-specific hurdle rates, year-to-year limits on capacity growth, and a variety of other information.

**Table 3.2. Biorefineries and Fischer-Tropsch (FT) poly-generation plants in CA-TIMES.**

Production Technology	Feedstock Types
<b>Cellulosic Ethanol Plants</b>	
Biochemical Pathway (50 or 100 million gal per year) Thermochemical Pathway (50 or 100 MGY)	Forest Residues Municipal Solid Waste, Paper Municipal Solid Waste, Wood Municipal Solid Waste, Yard Orchard and Vineyard Waste Pulpwood Agricultural Residues, Stovers/Straws Energy Crops
<b>Bio-Residual Fuel Oil Plants</b>	
Pyrolysis Bio-Oil Pathway (25 or 100 MGY)	Forest Residues Municipal Solid Waste, Mixed Municipal Solid Waste, Paper Municipal Solid Waste, Wood Municipal Solid Waste, Yard Orchard and Vineyard Waste Pulpwood Agricultural Residues, Stovers/Straws Energy Crops
<b>Renewable Bio-Diesel Plants</b>	
Hydro-treatment Pathway (50 or 100 MGY)	Yellow Grease Animal Tallow
<b>Fischer-Tropsch Poly-Generation Plants</b>	
Biomass Gasification (61 MGY) Biomass Gasification, w/ CCS (61 MGY)	Forest Residues Municipal Solid Waste, Mixed Municipal Solid Waste, Paper Municipal Solid Waste, Wood Municipal Solid Waste, Yard Orchard and Vineyard Waste Pulpwood Agricultural Residues, Stovers/Straws Energy Crops
Coal-Biomass Gasification, Syngas RC, w/ CCS (138 MGY) Coal-Biomass Gasification, Syngas OT, w/ CCS (112 MGY) Coal-Biomass Gasification, Syngas OT, w/ CCS (506 MGY)	Coal Forest Residues Municipal Solid Waste, Mixed Municipal Solid Waste, Paper Municipal Solid Waste, Wood Municipal Solid Waste, Yard Orchard and Vineyard Waste Pulpwood Agricultural Residues, Stovers/Straws Energy Crops

### 3.3 Hydrogen Production

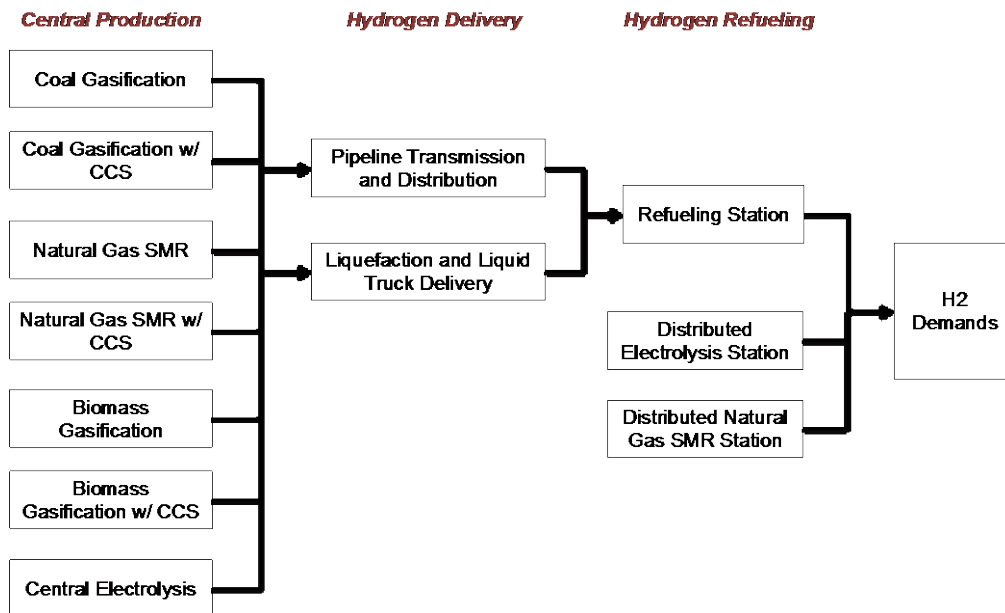
A more detailed spatial representation illustrating how hydrogen infrastructure can build out over time to meet regional demands has been developed as a standalone model described in detail in Section 7.1 and Appendix F.1 but has not yet been incorporated into the main CA-TIMES model.



Hydrogen production, delivery and refueling infrastructure is represented relatively simply in the current iteration of CA-TIMES. Hydrogen can be supplied to the various end-use sectors in CA-TIMES via a number of different pathways. The following hydrogen production technologies are available to the model in future years: Central production via coal gasification (w/ and w/o CCS), natural gas steam methane reformation (w/ and w/o CCS), water electrolysis, and biomass gasification (w/ and w/o CCS). Distributed production methods can be accomplished at the station using natural gas steam reforming and water electrolysis. Biomass gasification to produce hydrogen can be coupled with CCS to provide a negative emissions technology. Figure 3.5 shows the potential technology options for hydrogen production.

The cost of central production facilities is based upon reference sizes for each type of infrastructure from DOE’s H2A database (H2A 2005).

All hydrogen production plants only produced hydrogen and it is assumed that no electricity co-generation takes place (though many infrastructure elements can consume electricity, especially water electrolysis). All future hydrogen production technologies in CA-TIMES are characterized by energy resource and/or water input efficiencies, investment costs, and fixed and variable O&M costs. The technology and cost assumptions are based upon data primarily from DOE’s H2A database, though data from U.S. EPA’s 9-region MARKAL model (U.S. EPA 2008) is also used (for inputs like annual capacity factors, technology-specific hurdle rates, year-to-year limits on capacity growth, and a variety of other information).



**Figure 3.5. Simplified schematic of hydrogen production and supply technologies in CA-TIMES.**

After it is produced, hydrogen is distributed to end-use sector technologies by either pipeline or truck transmission and delivery technologies (see Figure 3.5). Distributed hydrogen production at the refueling station does not require any delivery technologies or associated costs. No spatial information is used in modeling of hydrogen delivery, instead an average distance is assumed for all central hydrogen production based upon average distances assumed in EPA’s MARKAL model.

Refueling station costs are based upon an assumed dispensing capacity of 2,740 kg/day. Each stage of hydrogen infrastructure, including production, delivery and refueling has associated costs, energy inputs

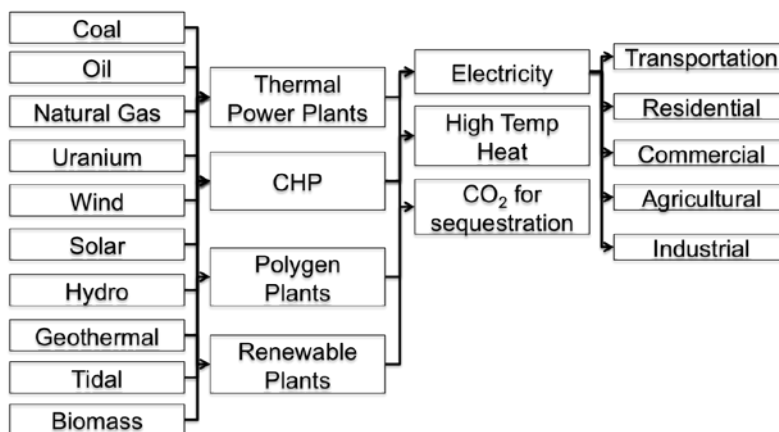
and emissions. These technology characterizations are based on the EPAUS9r MARKAL model U.S. EPA (2008), and the U.S. DOE’s Hydrogen Analysis (H2A) model (U.S. DOE 2008).

The representation of hydrogen infrastructure in CA-TIMES is a crude representation of how such a system would work. The two most important caveats include the lack of economies of scale in production and delivery infrastructure costs and the lack of spatial detail about hydrogen demand and delivery. These two issues are addressed in a separate analysis in Section 7.1, but have not yet been incorporated into the primary CA-TIMES model v1.5 and scenario analysis.

Without economies of scale represented in this model, costs for hydrogen production are represented as a cost per unit of capacity. This approach will underestimate the cost of building early infrastructure since systems to supply small amounts of hydrogen are invariably more expensive per unit of capacity than larger systems. This same issue arises especially with respect to pipeline delivery as cost does not scale linearly with hydrogen flow rate (Yang and Ogden 2007). Also important is the fact that CA-TIMES v1.5 does not specify location of hydrogen demands, which has an important impact on the scale of delivery infrastructure. CA-TIMES v1.5 treats all demand as coming from one region and thus all demands use average delivery distances.

### 3.4 Electricity Generation

The electricity supply sector consists of power plants that take in primary energy feedstocks (e.g., natural gas, biomass, uranium, wind, hydro, coal) and convert it into electricity, which can then be delivered and used to meet end-use energy service demands in the five end-use sectors (industrial, commercial, residential, agricultural, and transportation). Figure 3.6 shows a schematic representation of the electricity sector, including the resources, types of conversion plants, and electricity-using sectors.



**Figure 3.6. Schematic of electric sector resources, conversion plants and end use sectors.**

The California electricity system is treated as one large demand with no spatial detail. This means that power from any generator can be used to meet demand from any load without any intrastate transmission constraints. The one exception to this aspatial representation is how intermittent renewables are treated (this is discussed later in section 3.4.3).

The majority of electricity supply in the state is produced in dedicated electricity plants (thermal or renewable plants), while a fraction of electricity is produced in plants that also produce other products, such as heat, chemicals or fuels.

The CA-TIMES model minimizes total system cost, which in the electricity sector reflects investments in power plant capacity, operations and maintenance of plants, and operation and fuel use decisions. The

model accounts for the state’s existing stock of power plants in the base year, which is used to meet current and also near-term future demands. In order to meet the future demand for electricity (which is an endogenous decision in the model), the model chooses between available power plant technologies to invest in (i.e., capacity additions) and which power plants to operate (i.e., dispatch decisions), in order to match electricity supply and demand for each sub-annual timeslice, throughout the modeling period. CA-TIMES does not model individual power plants but tracks the capacity of power plants of different vintages (installation year) to account for differences in cost and/or efficiency.

The CA-TIMES model defines 19 power plant technologies to represent California’s current electricity generation stock, 11 different technologies representing electricity imports, and 25 power plant technologies are specified and available for future investment.

The CA-TIMES model also captures the cost of investing in new electrical transmission lines for “stranded” renewable resources that exist in remote regions of the western U.S. and Canada (e.g., solar, wind, and geothermal), which could contribute to California’s electricity supply mix in the future (RETI 2009, CPUC 2011).

### 3.4.1 Timeslices

While not limited to the electricity sector, the use of timeslices is most relevant to the operation and dispatch of electricity supply and the demand for electricity from the end use sectors. In an annual modeling period, CA-TIMES is broken into 48 sub-annual timeslices. This is significantly lower than many electricity simulation models (which typically include hundreds to thousands of time periods) but more than other similar energy system models (often with 6 to 12). Each model year of CA-TIMES is divided up into six “seasons”, or pairs of months, while each seasonal period is subsequently partitioned into eight three-hour time blocks, resulting in 48 timeslices.

“Seasonal” division	“Hourly” division
1JF - January/February	T1: 0:00 – 3:00
2MA - March/April	T2: 3:00 – 6:00
3MJ - May/June	T3: 6:00 – 9:00
4JA - July/August	T4: 9:00 – 12:00
5SO - September/October	T5: 12:00 – 15:00
6ND - November/December	T6: 15:00 – 18:00
	T7: 18:00 – 21:00
	T8: 21:00 – 24:00

An appropriate way to think about this division is that there are 6 representative days in the year (one for each two-month period). And these average days are broken into 3-hour blocks so the first timeslice 1JFT1 represents the midnight to 3am hours on an average January and February day.

This level of temporal resolution offers the ability to track some (but certainly not all) of the important variability in supply and demand. Timing for electricity demands is specified for each end use sector (or energy service). On the supply side, the availability of electric generators is specified within each timeslice based upon historical averages (for thermal plants) and resource availability (for renewables) for plants and resources in California.

The model must balance supply and demand of electricity in each and every timeslice<sup>6</sup>. Thus, additional generation in timeslices when demand is low has lower value compared to generation during peak demand timeslices.

### 3.4.2 Power plants

Detailed information about the state’s electric sector is derived from CBC (2009), McCarthy (2009), CARB (2010), CEC (2010), EIA (2011), CEC (2012). The list of technologies included in the model can be found in Table 3.3.

**Table 3.3. Electric Generation Technologies in CA-TIMES.**

Base-Year Technologies	Future Technologies
<p><b><u>Baseload</u></b>            Coal Steam            Biomass Steam (Woody Biomass)            Biomass Steam (Municipal Solid Waste)            Biomass Steam (Herbaceous Biomass)            Biogas from Landfills and Animal Waste Digesters            Geothermal            Nuclear, Conventional Light Water Reactors (LWR)</p> <p><b><u>Load following</u></b>            Hydroelectric, Conventional (Baseload and Peaking)            Hydroelectric, Reversible (Pumped Storage)            Oil Steam (Distillate, Jet Fuel, and residual fuel oil, RFO)            Diesel Oil Combustion Turbine            Diesel Oil Combined-Cycle            Natural Gas Combustion (Gas) Turbine (NGGT)            Natural Gas Steam Turbine (NGST)            Natural Gas Combined-Cycle (NGCC)</p> <p><b><u>Intermittent</u></b>            Wind            Solar Thermal            Solar Photovoltaic</p>	<p><b><u>Baseload</u></b>            Coal Steam            Advanced Coal Int. Gasif. Combined-Cycle (IGCC)            Advanced Coal Int. Gasif. Combined-Cycle (IGCC), w/ CCS            Biomass IGCC (Woody Biomass)            Biomass IGCC (Municipal Solid Waste)            Biomass IGCC (Herbaceous Biomass)            Biogas from Landfills and Animal Waste Digesters            Geothermal, in California            Geothermal, in Western U.S. Outside California            Nuclear, Conventional Light Water Reactors (LWR)            Nuclear, Pebble-Bed Modular Reactor (PBMR)            Nuclear, Gas Turbine - Modular Helium Reactor (GT-MHR)</p> <p><b><u>Load following</u></b>            Natural Gas Combustion (Gas) Turbine (NGGT)            Advanced Natural Gas Combustion (Gas) Turbine (NGGT)            Natural Gas Combined-Cycle (NGCC)            Advanced Natural Gas Combined-Cycle (NGCC)            Advanced Natural Gas Combined-Cycle (NGCC), w/CCS            Hydroelectric, Conventional (Baseload and peaking)            Hydroelectric, Reversible (Pumped Storage)            Molten Carbonate Fuel Cell</p> <p><b><u>Intermittent</u></b>            Wind, Onshore – by CREZ Group            Solar Thermal, - by CREZ Group            Solar Photovoltaic (Utility) – by CREZ Group            Solar Photovoltaic (Residential)            Tidal and Ocean Energy</p>

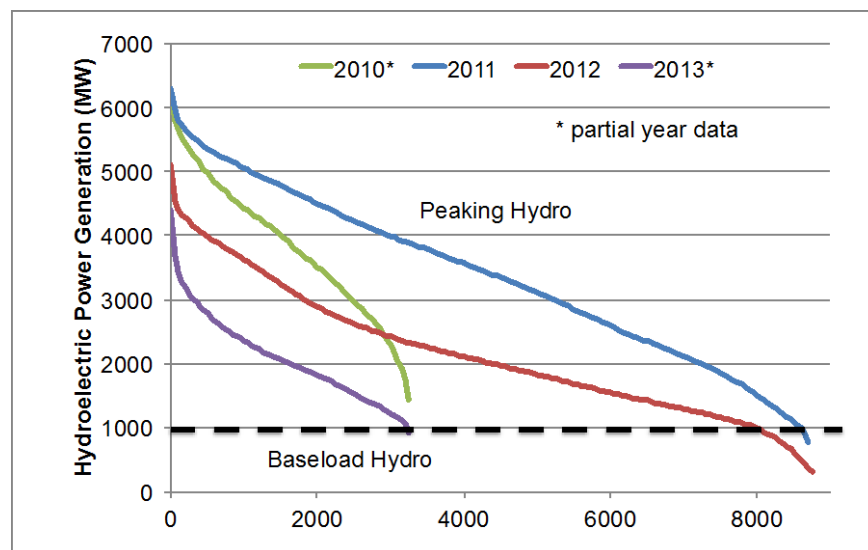
These power plant types can be broken into several categories based upon how they act within the model. The first are baseload thermal plants (e.g., nuclear, coal, biomass), which are run, more or less, at full capacity (~90%) in all sub-annual timeslices. These plants do not have the ability to be run at lower capacity factor. The second are load-following thermal plants (e.g., natural gas and fuel cell plants) that can vary their output on a timeslice basis. Because the model does not track individual power plants, but the overall capacity of specific types of power plants, the collective output from a given type of power plant can vary anywhere between 0% and maximum capacity (assumed to be 90%).

A third type is intermittent renewables (e.g. wind and solar plants) whose timeslice availability is an exogenous input to the model. Detailed analysis of historical and estimated solar and wind outputs for

<sup>6</sup> It is possible to have excess generation in a timeslice, which is then essentially wasted.

different locations in the western US has been done using NREL System Advisor Model data, using data from NREL's Solar Prospector and Western Wind Dataset (NREL 2013).

Hydro plants make up the last category of plants. Hydropower facilities are broken up into two types, conventional and pumped storage. Conventional hydropower in California consists of large dams and storage reservoirs. These are modeled as energy constrained resources, which have a certain quantity of energy generation over the course of the year and there is also seasonal variation in availability. We further break conventional hydropower into a baseload type, which has relatively constant generation (1/3 of total hydropower generation is assumed to run as a constant, baseload generator), and a peaking type, which is free to be dispatched up to hydropower capacity in order to meet demands as needed in any timeslice (2/3 of total hydropower is assumed to be available for load following). Figure 3.7 shows a historical generation duration curve for hydro for the last few years and hourly hydro generation is almost always over 1000 MW. This constant generation is represented by the baseload portion of hydro power plants whereas the variable hydro generation is represented by the peaking portion. Additionally, peaking hydropower generation is also constrained by season, as water is more available in winter, spring and early summer and less available during late summer and fall months. Pumped storage hydro is an energy storage technology that is assumed to be around 80% efficient (because of evaporation, pump and turbine losses).



**Figure 3.7. Load duration curve of historical large hydroelectric power generation in California. Data from CAISO (CAISO 2013).**

Biomass plants are split into three types depending upon the type of biomass they can use (woody, herbaceous or municipal solid waste). Each of the nine types of biomass described in CA-TIMES falls into one of these categories and is assumed to be equivalent to another kind of biomass of the same type.

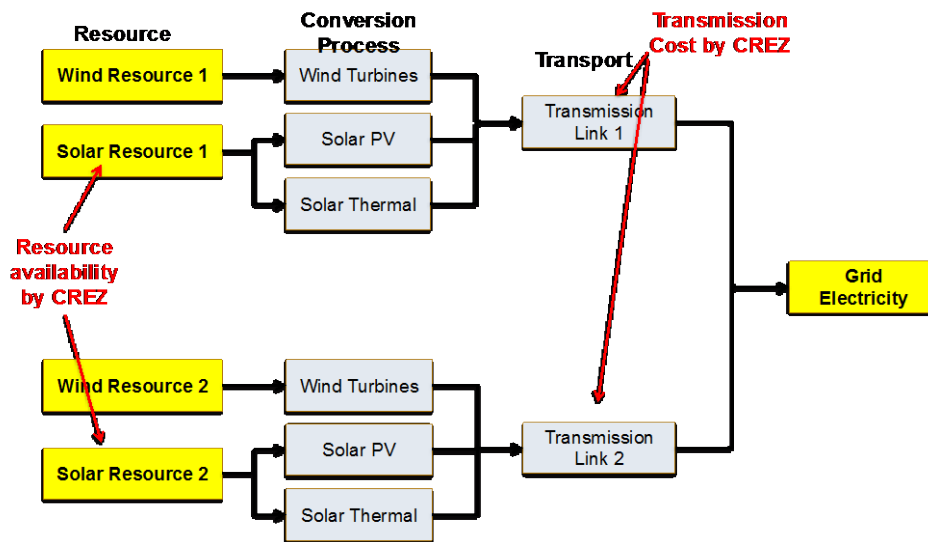
### 3.4.3 Renewable wind and solar resources and transmission

Since the introduction of the Renewable Portfolio Standard (RPS) policy, a number of studies have looked at how the state might meet the targets (CPUC 2009, RETI 2009, CPUC 2011). These studies identify wind and solar resources as the primary means of meeting the RPS, due to their relatively low cost and significant resource availability in California and in neighboring states. In addition, assessments of the location of these renewable resources and their availability have indicated that significant amounts of transmission capacity will need to be added in order to utilize these renewables (CPUC 2009, RETI 2009, WGA 2009).

The RETI project identified 59 Competitive Renewable Energy Zones (CREZ) that have significant renewable generation potential to contribute to meeting the demand in California (RETI) as well as identifying the transmission capacities and costs needed to connect these electricity sources to the California market. Data from Allan (2011) provided hourly profiles of potential wind and solar generation from each CREZ.

These 59 CREZs were aggregated to 23 CREZ groups (CGs) based upon shared use of representative transmission lines (RETI 2009) in order to reduce the modeling overhead. Each CG has potential wind and solar resources identified which has been mapped from the hourly profiles given by Allan (Allan 2011) to the 48 timeslices used in CA-TIMES.

The structure of remote renewable energy sources is shown in Figure 3.8.



**Figure 3.8. Structure of remote renewables for wind, solar PV and solar thermal power plants in Competitive Renewable Energy Zones (CREZ) groups.**

The first column (Resource) represents the availability of wind and solar resources in a given CG, which vary by the total resource availability (e.g., how much total energy is potentially available if wind or solar plants were built) and the timeslice availability (e.g., how much generation would be available in each timeslice). These vary depending upon the CG, which range from locations within California to many different western states, British Columbia and Baja Mexico.

The next column represents the actual conversion facilities (wind turbine, solar thermal power plant, solar PV plant) that convert the wind and solar resources into electricity within the CG. Costs for wind turbines and solar plants are all based upon the same costs but can vary because regional cost multipliers are used. This remote electricity needs to be brought to the population centers via newly built transmission lines. The output of these transmission lines is then part of the pool of electricity that is available for use in the end-use sectors. As stated earlier, the model must balance supply and demand for electricity during each timeslice, and thus the fixed timeslice profile of generation for wind and solar is important. If these resources are to be used in large quantities, their generation profiles must match with the profile of demand. Flexible, load-following resources like hydropower and natural gas become quite important to make up for shortfalls.

**Table 3.4. List of each CREZ group with solar and wind capacity, availability and transmission cost.**

<i>Primary CREZ</i>	<i>Solar Capacity (GW)</i>	<i>Solar Capacity Factor</i>	<i>Wind Capacity (GW)</i>	<i>Wind Capacity Factor</i>	<i>Transmission Cost (\$M/)</i>	<i>Transmission Capital Cost per GW (\$M/ GW)</i>	<i>Levelized* Transmission Capital Cost (\$/MWh)</i>
1 Lassen	-	-	2.01	0.30	22.28	11.09	0.64
2 Solano	-	-	0.89	0.19	6.11	6.84	0.63
3 Owens Valley	5.00	0.24	-	-	73.42	14.68	1.06
4 Inyokem/Tehachapi	17.33	0.27	4.39	0.34	127.93	5.89	0.36
5 Barstow	6.34	0.27	1.97	0.31	44.80	5.39	0.34
6 San Bern-Baker	4.13	0.26	0.18	0.26	31.40	7.29	0.48
7 Iron Mountain	6.61	0.27	0.06	0.19	96.41	14.46	0.94
8 Palm Springs	-	-	0.33	0.31	2.58	7.77	0.43
9 Riverside E	10.55	0.27	-	-	87.52	8.30	0.53
10 Imperial	5.07	0.27	0.12	0.23	87.90	16.94	1.11
11 San Diego	-	-	0.88	0.29	10.51	11.96	0.71
12 Carrizo	5.00	0.24	0.43	0.26	25.21	4.64	0.34
13 Westlands	5.00	0.20	-	-	23.20	4.64	0.40
14 Arizona	19.78	0.27	3.71	0.28	2,048.65	87.19	5.56
15 British Columbia	-	-	13.94	0.28	24,176.81	1,734.14	107.97
16 Baja	-	-	8.31	0.30	764.05	92.00	5.35
17 Idaho	-	-	1.65	0.30	2,498.42	1,514.97	87.86
18 New Mexico	-	-	13.19	0.39	3,624.10	274.84	12.22
19 Nevada	18.59	0.23	1.75	0.30	2,429.09	119.42	8.67
20 Oregon	-	-	2.91	0.27	2,045.36	702.17	44.67
21 Utah	-	-	1.68	0.30	562.65	335.16	19.40
22 Washington	-	-	3.26	0.28	1,075.19	329.59	20.67
23 Wyoming	-	-	14.85	0.34	7,923.31	533.44	26.89

\* Assumes 15% CRF - Source: RETI / A. Allan Thesis

Cost multipliers are used to estimate the cost of building wind and solar facilities in different regions (See Appendix A. The cost of electricity will vary between these different regions; due to these capital cost differences as well as the difference in resource availability, plant capacity factor and transmission cost and capacity. The value of electricity from these regions will also vary depending upon the timeslice profile of generation.

### 3.4.4 New power plant costs and efficiency

Table 3.5 shows the input capital cost and efficiency assumptions for CA-TIMES electricity sector power plants. Costs and efficiencies are shown for specific years and the values for other years are interpolated from the values displayed. This data comes primarily from AEO2012 (EIA 2012) and the SWITCH model (Nelson, Johnston et al. 2012). Costs and efficiencies are interpolated between data years.

Transmission lines for renewable generation in remote CREZ regions are assumed to have a 5% loss and costs for these lines is shown in Table 3.5. A comparison of our cost assumptions with the other studies is summarized in Appendix A.

**Table 3.5. Capital investment and plant efficiency assumptions for new power plants.**

Electric Power Plant Cost and Efficiency	Plant Capital Investment Cost (\$2010/kW)				Power Plant Efficiency (%)			
	2010	2015	2035	2050	2010	2035	2050	
Biogas from landfills and animal waste digesters	8727	8727	8727	8727	25.0%	25.0%	25.0%	
Biomass IGCC, Herbaceous (Energy Crop and Ag residue)	4168	3868	2871	2871	34.1%	37.9%	37.9%	
Biomass IGCC, MSW (Mixed, Paper and Yard MSW)	4168	3868	2871	2871	34.1%	37.9%	37.9%	
Biomass IGCC, Woody (Forest, Wood MSW, Orchard, Pulp)	4168	3868	2871	2871	34.1%	37.9%	37.9%	
Coal Steam	2844	2985	2115	2115	38.8%	39.0%	39.0%	
Advanced Coal Int. Gas. Combined-Cycle (IGCC)	3220	3366	2281	2281	39.2%	45.8%	45.8%	
Advanced Coal IGCC w/CCS	5990	6232	4101	4101	31.9%	41.1%	41.1%	
Natural Gas Combustion (Gas) Turbine (NGGT)	1208	980	538	538	31.8%	32.7%	32.7%	
Advanced Natural Gas Combustion (Gas) Turbine (NGGT)	859	897	582	582	35.0%	39.9%	39.9%	
Natural Gas Combined-Cycle (NGCC)	1221	1283	909	909	48.4%	50.2%	50.2%	
Advanced Natural Gas Combined-Cycle (NGCC)	1244	1302	875	875	53.1%	53.9%	53.9%	
Advanced Natural Gas Combined-Cycle (NGCC) w/CCS	2369	2462	1590	1590	45.3%	45.5%	45.5%	
Molten Carbonate Fuel Cell (Natural Gas)	7041	4158	2129	2129	35.9%	49.0%	49.0%	
Hydroelectric, Conventional	2347	2347	2347	2347	Renewable resources are characterized by their potential electricity generation so renewable power plants are generally assumed to have an efficiency of 100%			
Hydroelectric, Reversible (Pumped Storage)	2347	2347	2347	2347				
Geothermal	2513	2390	1955	1955				
Solar Photovoltaic (Residential)	5710	4453	2113	2113				
Tidal and Ocean Energy	7333	6723	4283	3333				
Wind Turbines (a)	2729	2662	2408	2408				
Solar Thermal Plant (a)	5301	5069	4239	4239				
Solar Photovoltaic Plant (a)	5373	4052	1895	1895				
Electricity Transmission from remote CREZ	Cost depends on distance and capacity					95.0%	95.0%	95.0%
Nuclear, Light Water Reactor (LWR)	5335	5466	3414	3414			1.53 PJ/IEU (b)	
Nuclear, Pebble-Bed Modular Reactor (PBMR)	4631	4745	2964	2964		2.76 PJ/IEU (b)		
Nuclear, Gas Turbine - Modular Helium Reactor (GT-MHR)	4157	4259	2660	2660		4.65 PJ/IEU (b)		

Notes: <sup>a</sup> Wind and solar plants in different CREZ zones have different transmission cost, capacity factor and hourly generation pattern

<sup>b</sup> Nuclear plants have efficiencies specified in units of PJ of electricity generated per tonne of input enriched uranium (PJ/IEU)

### 3.4.5 Electricity imports

A large share of California’s electricity is actually supplied from outside the state (~30% in 2010) and is categorized into two different types of imports: firm and system. Firm imports refer to generation from power plants located outside of California but owned by in-state utilities. System imports, on the other hand, refer to electricity produced by utilities outside the state that is only imported when available or needed – purchased on the spot market for electricity.

This imported electricity is generated primarily from natural gas, hydropower and coal plants. And as required by AB32, the energy use and emissions related to electricity imports are included in CARB’s official GHG Inventory (CARB 2009). Thus, within CA-TIMES, emissions and energy usage from electricity imports area counted in instate combustion emissions.

A key question for CA-TIMES, which models electricity generation out to 2050, is what are the costs, resource composition and emissions from electricity imports in the future? Because of the difficulty in answering this complex question, a simplifying assumption is made: imports are essentially phased out and future generation comes from “in-state” sources. In the CA-TIMES model, firm and system imports are assumed to decline to zero from 2010 to 2025.

Given the structure of the CA-TIMES model, it is preferable to represent all new electricity supply to California at the technology level (i.e., with investment cost, efficiency, and availability data), rather than as commodity flows; hence, future supplies of imports are subsumed as part of the mix of power plant technologies that the model chooses to build and deploy to meet California electricity demand. In other words, even though some of the power might be produced out of state it is assumed that it is built to serve California demands. The result is similar to, and thus modeled as if, all electricity generation post-2025 comes from instate generation. Note that electricity imports are also subject to the Renewable Portfolio Standard and emissions targets within the framework of CA-TIMES.



### 3.5 Greenhouse Gas (GHG) Emissions

Three categories of emissions are differentiated in the CA-TIMES modeling framework. The first category, *Included Instate emissions*, includes all GHGs produced from fuel conversion and processing (e.g., refinery emissions, biofuel or H<sub>2</sub> production plant emissions), transport and delivery, and combustion activities within the boundaries of California’s energy system. These emissions also include emissions from both instate and out-of-state electricity production for California. This category includes all emissions from activities in box 1 in Figure 3.9 (also see bin 1 in Table 3.6) and the carbon cap and emissions target for 2050 all focus on this first category of emissions.

The second category, *Overall Instate emissions*, includes additional emissions associated with fuel combustion from interstate and international aviation and marine transportation that is fueled in California. This category is still part of California’s energy system as these fuels must be supplied at the state’s ports and airports but are not included in the state’s official GHG emissions cap (CARB 2007). These emissions are shown in boxes 1 and 2 in Figure 3.9 and emissions bins 1 and 2 in Table 3.6.

The final category, *Lifecycle CA Energy emissions*, includes emissions from the first two categories but also additional emissions sources such as emissions that result from transporting primary energy feedstocks (e.g., crude oil, natural gas, coal, uranium, biomass) or finished fuels (e.g., refined petroleum products, biofuels) from outside of the state into California as well as the upstream lifecycle (“well-to-tank”) emissions resulting from production/conversion of these feedstocks/fuels outside of California. These emissions are shown in boxes 1, 2 and 3 in Figure 3.9 and emissions bins 1-3 in Table 3.6. California imports more energy than any other US state (approximately 67% in 2009) (EIA 2013) and as a result, the first two emissions categories exclude a substantial portion of emissions related to the state’s energy usage.

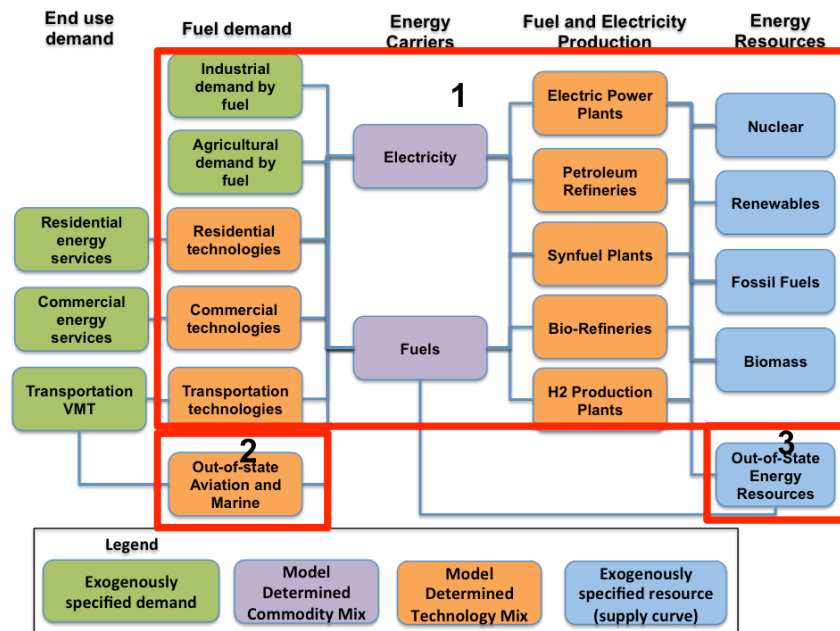


Figure 3.9. CA-TIMES model structure and emissions categories.

California tracks emissions from categories 1 and 2 in their official inventory, though only category 1 (*Included Instate emissions*) emissions are included in the cap for the purposes of meeting California’s current climate change law for 2020 (AB32) and presumably the 2050 target.

**Table 3.6. Emissions bins tracked in CA-TIMES.**

#	Emissions Bins	Description
1	Included Instate Emissions	Emissions from all fuel combustion activities occurring solely within CA <b>and</b> <i>imported</i> electricity emissions
2	Out-of-state transport emissions	Emissions from interstate and international aviation and marine trips fueled in CA
3	Out-of-state supply emissions	Upstream (i.e., life-cycle) emissions associated with producing and transporting energy resources from out of state for use in CA

While combustion emissions from interstate and international aviation and marine activities are specifically excluded from the emissions cap, they are important from a climate perspective. If we truly need to make significant reductions in GHG emissions from all sources of GHG emissions (and not just “Included” emissions), then including these activities in the cap makes sense, but also makes the cap more difficult to achieve. However, excluding these activities from the cap ignores a significant and growing source of GHG emissions and overstates the climate impact of an 80% reduction in emissions.

## 4. DEMAND SECTORS

CA-TIMES has five end-use sectors: transportation, residential, commercial, industrial, and agricultural and non-energy sectors. Each sector is represented with various degree of details, with the most detailed representation of transportation, followed by commercial and residential sectors, and simplified representation of industrial, agricultural and non-energy sector. They are described in detail in sections below.

### 4.1 Transportation

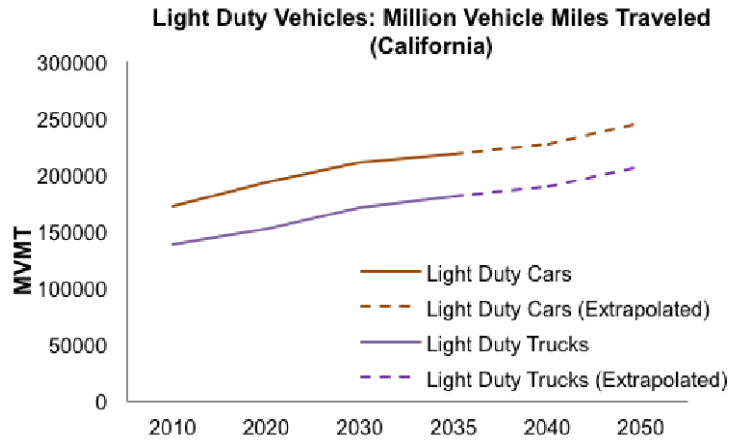
The transportation sector is the leading emitter contributing 45% of total emissions (CARB 2013)(Figure 1.2) (35% comes from in-state emissions, while the other 10% comes from domestic and international aviation and international marine bunker fuel use). Therefore, in order to reach any emissions target, a detailed analysis of the different modes of transportation sector is necessary. The current version of the CA-TIMES model consists of detailed end-use representation in vehicle-miles traveled, for the different sub-sectors in transportation, such as light-duty cars, light-duty trucks, medium-duty vehicles, heavy-duty vehicles, buses, trains, marine vessels, and aircrafts. The sub-sectors have a multiple vehicle technology running on different fuels represented, ranging from gasoline vehicles to fuel-efficient and advanced vehicle technologies, such as battery electric, plug-in hybrid and fuel cell vehicles. The assumptions for each end-use demand are briefly described below and detailed assumptions of technology costs and efficiencies are included in Appendix B.

The structure of the transportation sector in the current CA-TIMES model remains the same as the CA-TIMES v1.0 model (McCollum, Yang et al. 2012). The base year data and demand trajectory for the business-as-usual scenario are updated for most of the modes in the transportation sectors, wherever the data was available. In the cases where the updated data was not available, we directly extrapolate data from the CA-TIMES v1.0 model. The source data for all the modes are described in detail in the following subsections.

#### 4.1.1 Light-duty cars and trucks

The vehicle miles traveled (VMT) projections for the light-duty sector come from the EMFAC 2011 (CARB 2011) model developed by California Air Resources Board. The VMT data projections for the light-duty cars come from the LDA (passenger car) category, and the data for the light-duty trucks are represented from the combined categories of LDT1 (Light-Duty Trucks, 0-3750 lbs.), LDT2 (Light-Duty Trucks, 3751-5750 lbs.) and MDV (Medium-Duty Trucks, 5751-8500 lbs.) categories. EMFAC model projects the VMT data until the year 2035, the values are then linearly extrapolated from the trajectory till the year 2050. The vehicle stock for the base year 2010, for the gasoline and diesel vehicles is taken from the EMFAC model. For the hybrid and electric vehicle stock, the California DMV data facts for the year 2010 are used. It is assumed that, in the base year (2010), 90% of the registered hybrid vehicles in California are light-duty cars, and the rest are assumed to be light-duty trucks. All the electric vehicles registered according to the DMV data in the base year are assumed to be light-duty cars, as the share of the light-duty trucks might be too small to be represented compared to other base year vehicle technologies, so they are ignored. The miles traveled per vehicle for the base year are also calculated from the EMFAC model.

Figure 4.1 shows the VMT data based on EMFAC model data and our extrapolation for light-duty cars and light-duty trucks.



**Figure 4.1. Vehicle miles traveled demand of light-duty cars and trucks.**

The projections of costs and efficiencies for the new vehicle technologies are mostly obtained from AEO 2013 Reference case values (U.S. EIA 2013) modified based on our expert judgment based on the review of our assumptions in the literature (see Appendix B). The costs were converted to 2010 dollars. For the vehicle technologies that were not present in the AEO case, the costs were taken from the CA-TIMES v1.0 model, and were converted to 2010 dollars. These assumptions are detailed in Appendix B.

#### 4.1.2 Motorcycles

The VMT data projections for motorcycles are taken from the EMFAC model from the MCY (Motorcycle) category. The stock of motorcycles for the base year is taken from the California DMV data. The miles traveled per motorcycle are calculated from the EMFAC model (Figure 4.2). The costs and efficiency values were retained the same as the CA-TIMES v1.0 model, except that the costs were converted to 2010 dollars. These assumptions are detailed in Appendix B.

#### 4.1.3 Medium-duty vehicles and heavy-duty vehicles

The VMT projections for medium-duty vehicles are taken from the EMFAC model for the combined categories of:

- a) LHDT1 (Light-Heavy-Duty Trucks, 8501-10000 lbs.)
- b) LHDT2 (Light-Heavy-Duty Trucks, 10001-14000 lbs.)
- c) All the T6 category vehicles that are less than 26,000 lbs.

The VMT projections for heavy-duty vehicles are taken from the EMFAC model for the combined categories of T6 (>26,000 lbs.), T7 or above vehicle categories (Figure 4.2). The vehicle stock numbers for gasoline and diesel technologies for the base year are taken from the EMFAC model. The miles traveled per vehicle for each vehicle technology are also calculated from the EMFAC data. The cost and efficiency values are assumed from the International Energy Agency's Energy Technology Perspectives report (IEA, 2008), and the dollars values are converted to the year 2010.

#### 4.1.4 Buses

Three categories of buses are represented in the CA-TIMES model: Transit bus, School bus, Intercity & other buses. The transit bus VMT data projections are taken from the EMFAC model's UBUS (urban bus) category, school bus VMT data projections are taken from the EMFAC model's SBUS (school bus) category, and the Intercity & other bus VMT data projections are taken from the EMFAC model's OBUS (Other bus) category (Figure 4.2).

The stock of gasoline buses for all the three categories are taken from the EMFAC model, along with the calculation of miles traveled per gasoline bus. The stock of diesel, hybrid and electric buses for transit buses are calculated from National Transit Database from their energy consumption shares among the total number of operating buses. The diesel stock for the intercity buses is assumed the same as the CA-TIMES v1.0. The costs and efficiencies of these buses are also taken from the CA-TIMES v1.0 model, and the investment costs of buses are converted to 2010 dollars. These assumptions are detailed in Appendix B.

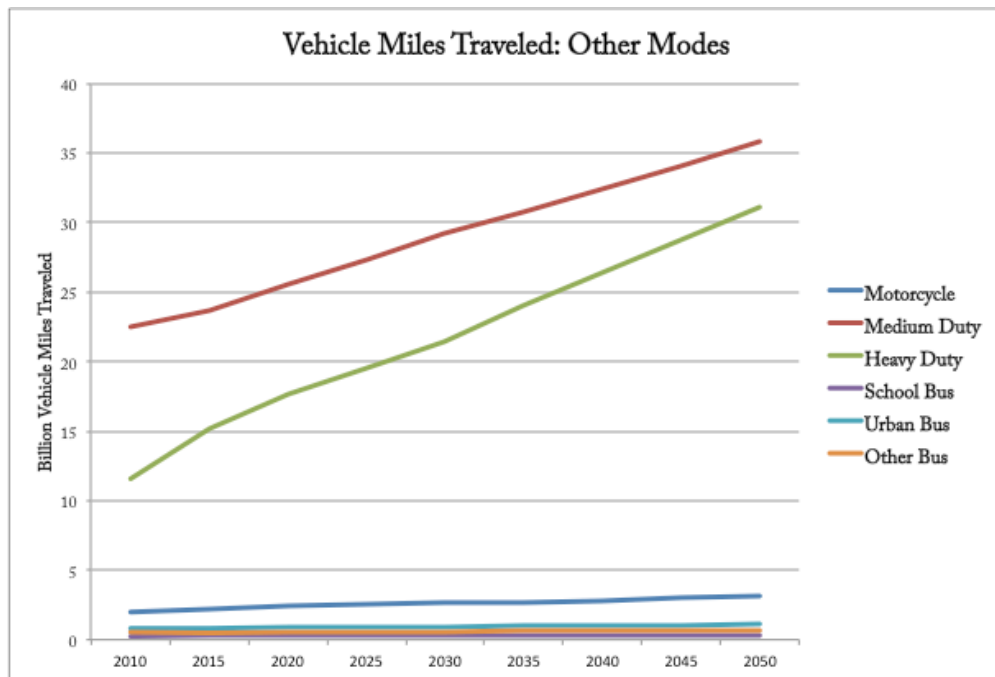


Figure 4.2. Vehicle-miles traveled data for modes other than light-duty sector vehicles

#### 4.1.5 Passenger rail

Four categories of passenger rail are represented in the CA-TIMES model: Commuter rail, heavy rail, light rail and intercity rail. The end-use demand for these categories is represented in passenger miles traveled. The train-miles traveled are obtained from the National Transit Database for the year 2010 (NTD, 2010) for the commuter rail, heavy rail and light rail categories. The cable car data is included in the light rail category. The intercity passenger miles are calculated from National Transit Database and Amtrak passenger boardings for the state of California in the year 2010. The train-miles for intercity trains are calculated from the load factor and passenger-miles data.

The load or occupancy factors for passenger rail (passengers/vehicle and vehicles/train) are assumed to be the same as the CA-TIMES v1.0 model, which were calculated from National Transit Database (NTD, 2005). The load factor (passengers/vehicle) for intercity trains is updated from Amtrak database for the year 2010 (Amtrak 2010).

The stock of trains per fuel type for these categories were obtained from National Transit Database (NTD, 2010). The train-miles traveled per train per year are calculated based on the above data (train-miles and stock) in the model. The costs and efficiencies of these trains are taken from the CA-TIMES v1.0 model, and the investment costs of trains are converted to 2010 dollars. These assumptions are detailed in Appendix B.

#### **4.1.6 Domestic freight (air, rail and shipping)**

Both interstate and intrastate freight data for the three major modes: air, rail and shipping are obtained from Oak Ridge National Laboratory's FAF3 (Freight Analysis Framework Version 3) model database (ORNL 2013). The end-use demand data are represented in million-ton-miles traveled (MTMT). The FAF3 model has the domestic (national) freight data, also has the capability to obtain the state-specific data: from, to and within the given data. Also, all the freight data includes domestic, import and exports for the state. The freight data 'within' California are considered as intrastate, and freight data 'from' and 'to' California are considered as interstate. The freight rail data has combined interstate and intrastate ton-miles.

The ton-miles traveled are projected till the year 2040; the data for the later years are linearly extrapolated till 2050. The vehicle configuration data for the freight rail (vehicles/train) and load factor (tons/cars) were calculated in the CA-TIMES v1.0 model from the ton-miles, vehicle miles and train miles data, determined from BTS (2005) calculations. The ton-miles are updated from the FAF3 data (ORNL 2013), but the database does not have the updated vehicle miles and train miles data. Hence, the vehicle configuration (vehicles/train) and load factor for the freight rail (tons/cars) was assumed to be the same as the CA-TIMES v1.0 model.

Stock for the freight rail cars were calculated based on the load factor and FAF3 model's kiloton by mode. The stock for the marine shipping vessels were calculated from the waterborne tonnage data from US Army Corps of Engineers (USACE, 2007). The stock of freight airline data was assumed to be the same as the CA-TIMES v1.0 model, which was obtained from California Air Resources Board (CARB, 2008). The costs and efficiencies of these freight modes are also taken from the CA-TIMES v1.0 model, which was obtained from ETP report (IEA, 2008); and the investment costs are converted to 2010 dollars.

#### **4.1.7 Domestic (interstate and intrastate) passenger aviation**

The passenger aviation data within California, and to and from California, were obtained from the Bureau of Transportation Statistics aviation (BTS 2010) database. The BTS data contains the number of passengers boarded in each flight, and the distance category of each flight (specified in 500 mile divisions). The total number of passenger miles traveled for the year 2010 is calculated and calibrated based on the 2005 data. Since the distance categories are separated into 500-mile divisions, it is harder to gauge the exact passenger-miles traveled. By comparing the similar data for the year 2005, it is calculated that the passenger miles traveled is about 70% of the total number of passenger miles obtained from the BTS data calculations with 500 mile intervals. The same percentage value is used to determine the 2010 data. The stock values for passenger aviation are obtained from California Air Resources Board (CARB 2008). Investment costs are obtained from Boeing (2007); and efficiencies for the passenger aviation airlines are calculated from the airplane energy intensity data from Bureau of Transportation Statistics (BTS 2010).

#### **4.1.8 Natural gas pipelines**

The pipeline consumption of natural gas in the state of California is updated for the year 2010 (EIA 2010). The pipeline efficiency for the base year was also updated from the EIA data.

#### **4.1.9 Other transportation**

The following end-use data demand sectors were extrapolated from the CA-TIMES v1.0 model. For this revised version of the model, the extrapolated 2010 data was used as a baseline. The stock, cost and efficiencies are retained from the previous model version. The data sources for these sectors are listed in Table 4.1:

- International freight data (air, rail and shipping)
- Harbor craft
- Personal recreation boats
- General aviation
- International passenger aviation
- International shipping
- Off-road and construction
- Agriculture

Table 4.1 summarizes transportation technology subcategories, units for end-use demand, and data sources for demand and technology assumptions.

**Table 4.1. Summary of data sources for transportation demand and technology by subcategory.**

Sub-category	Demand Unit	Demand data	Technology data
Light-duty cars and trucks	MVMT	EMFAC (2011) to 2035 and linearly extrapolated to 2050	AEO 2013 and ARB ZEV Regulation
Motorcycles	MVMT	EMFAC (2011) to 2035 and linearly extrapolated to 2050	CEC IEPR and Caltrans MVSTAFF
Medium-duty vehicles and Heavy-duty vehicles	MVMT	EMFAC (2011) to 2035 and linearly extrapolated to 2050	Energy Technology Perspectives report (IEA, 2008)
Buses	MVMT	EMFAC (2011) to 2035 and linearly extrapolated to 2050	Various sources (See Appendix B)
Passenger rail	MPMT	National Transit Database (2005)	US Environmental Protection Agency (2006)
International Shipping	Million Vessel miles	CARB's Oceangoing ship survey (2005)	Energy Technology Perspectives report (IEA, 2008)
Domestic freight (air, rail and shipping)	MTMT	Oak Ridge National laboratory's FAF3 (Freight Analysis Framework Version 3) to 2040 and linearly extrapolated to 2050	Energy Technology Perspectives report (IEA, 2008)
Domestic (interstate and intrastate) passenger aviation	MPMT	Bureau of Transportation Statistics: Aviation (2010)	Boeing (2007)
International passenger aviation	MPMT	California Air Resources Board (2008).	Boeing (2007)
International freight aviation	MTMT	California Air Resources Board (2008).	Energy Technology Perspectives report (IEA, 2008)
General aviation	Million hours	FAA (2007)	FAA (2007)
Harbor Craft and Recreational boats	Million hours	CARB's Harbor Craft survey (2004) and OFFROAD model (2007)	
Off-road and construction vehicles	Million hours	CARB's OFFROAD model (2007).	CARB's OFFROAD model (2007).
Agricultural vehicles	Million hours		
Natural gas pipeline	PJ	EIA (2010)	This transport subsector is treated differently from the other subsectors since there is no stock or annual average activity.

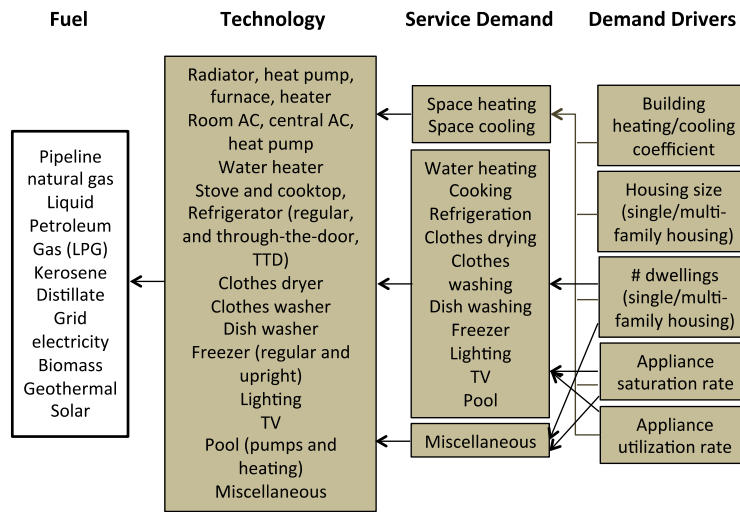
MVMT: Million Vehicle miles traveled; MPMT: Million passenger miles traveled; MTMT: Million-ton-miles traveled

## 4.2 Residential End Use Sector

The building sector is a large consumer of energy, it currently consumes about 40% of final energy in the US (EIA 2011); and it contributes to 13% of CO<sub>2</sub> emissions from fossil fuel combustion directly in California (not accounting emissions from electricity use) (Figure 1.2). The building sector generally includes commercial and residential sectors; in CA-TIMES model we address commercial and residential sectors separately. In this section we describe the residential sector demand and in Section 4.3 the commercial sector will be explained. Most other models have treated these two sectors either exogenously (assumed energy use and GHG emissions follow historical trends) or ignore economic interactions (such as efficiency improvement vs. demand response to fuel prices). Given the assumed drastic technology/efficiency improvements in buildings to meet the statewide 80% GHG emission reduction goal by 2050, it is important to understand the trend of energy consumption and the potential effects of climate policies on this sector.

California has always had a leading role in adopting efficiency standards and building codes in the United States and even in the world since the 1970s. Many believe that these standards have had a significant effect in reducing energy consumption in California. For instance, Geller et al. (2006) indicated that efficiency standards and codes cut electricity use by about 7% of statewide electricity consumption as of 2000. California residential energy consumption per capita and per household have been on decreasing trends since 1980, and are significantly lower compared with other states (Bernstein, Lempert et al. 2000). These efficiency improvements resulted in a variety of economic benefits, including lower household spending on energy and higher GDP growth (Bernstein, Lempert et al. 2000). Using the of CA-TIMES model, we can study the effects of different policies including sector-specific policies such as building efficiency standards and economy-wide carbon policies and how they affect the future energy use and technological adoption in these two sectors.

The residential sector in CA-TIMES model is broken into thirteen service demands, including space heating, space cooling, water heating, lighting, cooking, refrigeration, clothes washing, clothes drying, dish washing, freezing, TV, pool pump, and miscellaneous. Service demand of space heating, space cooling, water heating and lighting is calculated separately for single family and multi-family housing. These service demands are satisfied by end-use technologies, like central A/C, incandescent light bulbs, natural gas heaters, etc. These end-use technologies use fuels that come from electricity, natural gas, LPG, solar and wood biomass in the supply sector. The diagram of so-called reference energy system (RES) of this sector can be seen in Figure 4.3.



**Figure 4.3. The structure of residential RES describing energy service demands, fuel types and technologies in California. “Demand drivers” are exogenous to the model.**



We first calibrate end-use service demand to the base year (2010) and then project the service demand up to 2050 based on a few socio-economic drivers. By specifying energy service demands (e.g., heated space, cooled space, lighted space, heated water, etc.) for the base year and how they change over time based on drivers such as population growth and housing sizes, we exogenously specify fixed service demand changes over time. These drivers include the projected increase in housing unit size, number of dwelling, utilization rate, appliance saturation rates, and housing stock heating/cooling coefficient.

The model endogenously optimizes investment in end-use technologies based on economic factors (including technology costs and fuel prices), consumer choices (technology-specific discount rates and service demand changes in response to prices if running with elastic demand), technology availability, and policy constraints and calculates total statewide residential technology adoption and energy uses over time. The final energy demand (energy consumption) is determined by the model endogenously selecting different end-use technologies and their fuel input and efficiency assumptions. The model selects the end-use technologies to satisfy energy service demand while minimizing the total system cost (not just sector specific costs) and satisfying user-defined constraints such as technology or building efficiency standard, economy-wide or sectorial-specific GHG emission target, incentives (e.g., subsidies or rebates), etc.

End-use service demands (ES) of residential sector are calculated based on the following equation in our model:

$$ES_{u,t} = \sum_D \sum_t N_{i,u,D,t} \times UE_{i,u,D,t} \times Eff_{i,u,D,t} \quad (\text{Equation 4.1})$$

Where,

$ES_{u,t}$	Energy service demand $u$ at time $t$ (PJ <i>delivered</i> /year or PJ of useful energy per year)
$N_{i,u,D,t}$	Stock of technology $i$ for energy service demand $u$ for dwelling type $D$ at time $t$ (number of units)
$UE_{i,u,D,t}$	Fuel use of technology $i$ for energy service demand $u$ for dwelling type $D$ at time $t$ (PJ <i>consumed</i> /unit/year or PJ of final energy per unit per year)
$Eff_{i,u,D,t}$	Energy efficiency of technology $i$ for energy service demand $u$ for dwelling type $D$ at time $t$ (PJ <i>delivered</i> /PJ <i>consumed</i> ).

The projections for all of service demands are based on Equation 4.2 except space heating and cooling are calculated based on Equation 4.3.

$$ES_{u, 2050} = ES_{u, 2010} \times (1 + \Delta \# \text{ of Dwellings}) \times (1 + \Delta \text{Saturation rate}) \times (1 + \Delta \text{utilization rate}) \quad (\text{Equation 4.2})$$

$$ES_{u, 2050} = ES_{u, 2010} \times (1 + \Delta \# \text{ of Dwellings}) \times (1 + \Delta \text{Saturation rate}) \times (1 + \Delta \text{utilization rate}) \times (1 + \Delta \text{Housing heating / cooling coefficient}) \quad (\text{Equation 4.3})$$

Where  $\Delta$  represents the percent change between 2010 and 2050.

Residential energy service demand, fuel use, and technology are summarized in Table 4.2 below.

**Table 4.2. Characteristics of residential sector: fuel use, technology, service demand and demand drivers.**

Fuel	Technology	Service Demand	Temporal Resolution	Demand Drivers
Electricity, natural gas, LPG, wood	Radiator, heat pump, furnace, heaters	Space heating	Seasonal (bi-monthly)	Number of dwelling units (population), housing size, building heating/cooling coefficient, appliance saturation rate, appliance utilization rate
Electricity, natural gas	Room AC, central AC, heat pump	Space cooling	Full timeslice detail (8 periods/day in each two month “season”)	
Electricity, natural gas, LPG, solar	Water heater	Water heating	Full timeslice detail (8 periods/day in each two month “season”)	Number of dwelling units (population), appliance saturation rate, appliance utilization rate
Electricity, natural gas, LPG	Stove and cooktop	Cooking	Annual	
Electricity	Refrigerator	Refrigeration	Annual	
Electricity, natural gas	Clothes washer	Clothes washing	Annual	
Electricity, natural gas	Clothes dryer	Clothes drying	Annual	
Electricity, natural gas	Dish washer	Dish washing	Annual	
Electricity	Freezer (regular and upright)	Freezers	Annual	
Electricity	TV	TV	Annual	
Electricity, solar thermal	Pool (pumps and heating)	Pool	Annual*	
Electricity	Light bulbs	Lighting	Full timeslice detail (8 periods/day in each two month “season”)	
Electricity, natural gas	Dummy technology	Misc.	Annual	Number of dwelling units (population)

\* Even though pool energy demand should be modeled seasonally, we ignore the time slice of this demand to simplify the model since the demand is small.

As shown in Table 4.2, the temporal resolution of the service demands varies. Space heating is defined with bi-monthly resolution, while space cooling, water heating and lighting resolutions are defined with 3-hour intervals (8 time slices per day), and every two-month (6 time slices per year). The rest of service demands have annual resolutions.

#### 4.2.1 End-use demand drivers

This section describes residential demand drivers and their projection to the year 2050.

##### 4.2.1.1 Population, number of dwellings and housing unit size

We use the population projection from California Department of Finance (CADOFF 2013) and the number of dwelling units from the census data ([http://quickfacts.census.gov/qfd/download\\_data.html](http://quickfacts.census.gov/qfd/download_data.html)). We assume the same population growth rate in single family and multi-family households and project the total number of single and multi-family households in California. Mobile homes are included in the single family households. The total single family and multifamily dwellings are estimated to grow from 9.4 million and 4.2 million dwellings to 13 million and 5.3 million dwellings in 2050, respectively. The share of single and multi-family households in 2010 is 69.2% and 30.8% and it is estimated to increase slightly to 70.8% and 29.2% in 2050. The detailed data is shown in Table 4.3.

**Table 4.3. Number of dwelling units and housing unit size, 2010 - 2050.**

	Number of Dwelling Units			Housing Unit Size (sq. ft.)		
	2010 (1000s)	2050 (1000s)	Growth (%)	2010 (1000s)	2050 (1000s)	Growth (%)
Single-family housing (SFH)	9,467 (69.2%)	13,073 (70.8%)	38%	2,100	2,753	31%
Multi-family housing (MFH)	4,213 (30.8%)	5,390 (29.2%)	28%	843	1033	23%
Total	13,680	18,212	35%			

Based on EIA's 2009 Residential Energy Consumption Survey (RECS) Housing Characteristics Tables (Table HC10.15), the average square feet per housing unit in the West region in 2009 were 2,100 sq. ft. and 843 sq. ft. for single-family homes (SFH) and multifamily homes (MFH), respectively (EIA 2013). The average sizes for both housing types have increased substantially over the years, 34.6% and 13% increase for SFH and MFH, respectively, when comparing houses constructed in the 1970s versus houses constructed in 2000s (EIA 2013). The annual average growth rates are 0.68% for SFH and 0.51% for MFH. Over the period of 40 years, we linearly extrapolate that the housing size will increase 31% and 23% for SFH and MFH, respectively.

#### 4.2.1.2 Housing heating and cooling coefficients

The housing heating coefficient measures the energy demand per unit area of dwelling (BTU/sq. ft./Degree Days/yr). Table 4.4 shows the assumed changes in average heat loss coefficient over time; the assumption is based on Rufo and North (2007) which reflects projections of the construction and insulating materials used in the U.S.

**Table 4.4. Estimated housing heating and cooling coefficient and percent changes, 2010-2050.**

	2010	2015	2020	2025	2030	2035	2040	2045	2050	Change (2010-2050)
Cooling coefficient	9.65	10.03	10.18	10.28	10.14	9.92	9.71	9.49	9.28	-4%
Heating coefficient	5.6	5.5	5.37	5.23	5.04	4.86	4.68	4.49	4.32	-23%

#### 4.2.1.3 Appliance saturation rate

Appliance saturation rate is the percentage of homes (SFH or MFH) that has one or more of an appliance. Appliance saturation rates show the penetration of different appliances in the state's households. Data for appliance saturation for natural gas and electricity appliances is taken from several CEC reports (Rufo and North 2007, McCarthy, Yang et al. 2008) estimated by housing type as shown in Table 4.5 below. These tables show the relative change (in percentage) from 2010 to 2050. For space heating, cooling and water heating we used the specific number for single and multi-family houses and for the rest of end-uses we calculated the weighted average of single and multi-family houses using the growth rate of each housing type. In the CEC report, the equipment saturation rates are estimated separately for different fuel types. Thus, for calculating the change of saturation rate within space heating and cooling, water heating, clothes drying and cooking regardless of fuel type we weight the changes in saturation rate by fuel type by their energy use in 2010.

**Table 4.5. Percent changes in appliance saturation rates by dwelling type and by end-use, 2010-2050.**

	Electricity						Natural Gas					
	Single-family			Multi-family			Single-family			Multi-family		
	2010	2050	%	2010	2050	%	2010	2050	%	2010	2050	%
Space Heating	7%	7%	6%	28%	29%	6%	80%	79%	-1%	68%	67%	-2%
Fan for Gas Furnace	44%	44%	1%	25%	27%	7%						
Central AC	38%	51%	32%	31%	41%	33%						
Room AC	10%	7%	-27%	17%	16%	-11%						
Water Heating	8%	8%	0%	16%	16%	2%	82%	84%	2%	74%	80%	9%
Dishwasher	77%	80%	3%	64%	70%	9%						
Clothes Washer	96%	97%	1%	80%	84%	5%						
Clothes Dryer	49%	52%	7%	47%	51%	8%	37%	44%	17%	26%	36%	40%
Cooking	45%	47%	6%	50%	53%	5%	44%	47%	7%	53%	42%	-21%
Refrigerator	116%	112%	-4%	105%	105%	0%						
Freezer	30%	34%	13%	9%	11%	20%						
Swimming Pool Pump	14%	15%	7%	2%	2%	6%						

SFH: single-family housing; MFH: multi-family housing

Lighting demand is estimated separately based on unit energy consumption and grows by 15 kWh per year or 1 percent annually for single-family households and 5 kWh per year or 0.8 percent annually for multi-family households (CEC 2007, Rufo and North 2007).

**Table 4.6. Projected changes in lighting demand from 2010 level.**

Unit	Single-family housing	Multi-family housing
2010-2050	49%	38%

#### 4.2.1.4 Appliance utilization rate

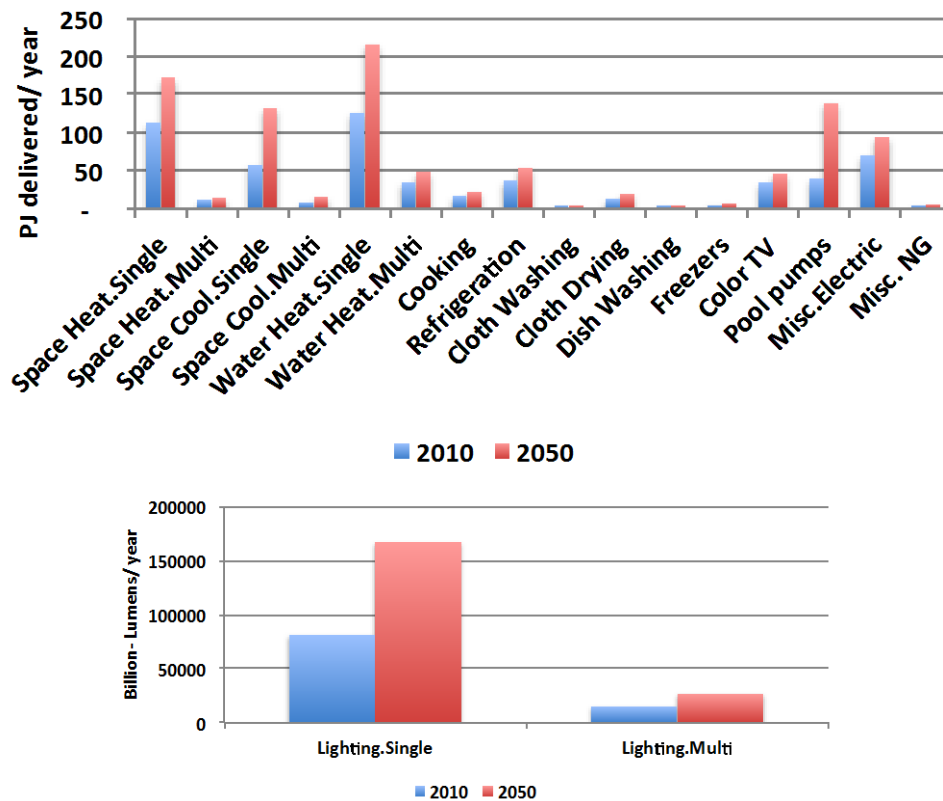
Appliance utilization rate describes how much more usage is expected *per appliance* or *per household* given increased demand per household (Table 4.7). Increased appliance utilization rate results in increases in service demand and/or increases in technology annual availability factor (AFA) or capacity factor (CF) at the technology level. This increased appliance utilization rate is reflected in the decreased service demand as well as in increased technology annual availability factor (AFA) or capacity factor (CF) at the technology level (CEC 2007, Rufo and North 2007). The estimates below are for electric appliance, though we assume the same rate of increase across all fuel types. For space heating, space cooling and water heating we used specific number for single and multi family units; however, for the rest of end-uses we calculated weighted number for all housing units by weighting them using the number of each type of household in 2010.

**Table 4.7. Estimated relative percent changes in appliance utilization rate, 2010-2050.** Source: (CEC 2007, Rufo and North 2007).

	Single-family housing	Multi-family housing	Weighted
Space heating	1.10	1.05	
Space cooling	1.10	1.05	
Water heating	1.02	1.00	
Dishwasher	1.06	1.00	1.044
Clothes Washer	1.05	1.00	1.038
Clothes Dryer	1.06	0.94	1.023
Miscellaneous	1.50	1.60	1.531
Cooking	1.06	1.00	1.040
Refrigerator	1.10	1.05	1.084
Freezer	1.00	1.00	1.000
Swimming Pool Pump	0.99	1.00	0.990

Note: Assuming no change for TV.

Given the assumed changes in demand drivers described above (number of dwelling units, housing size, building heating/cooling coefficient, appliance saturation rate, and appliance utilization rate), the projected service demand changes for residential sector for 2010-2050 are illustrated in Figure 4.4. Energy service demands with the highest percent changes that are greater than 100% are space cooling – single family homes, lighting – single family homes, lighting – multifamily homes, space cooling – multifamily homes, and pool pumps.



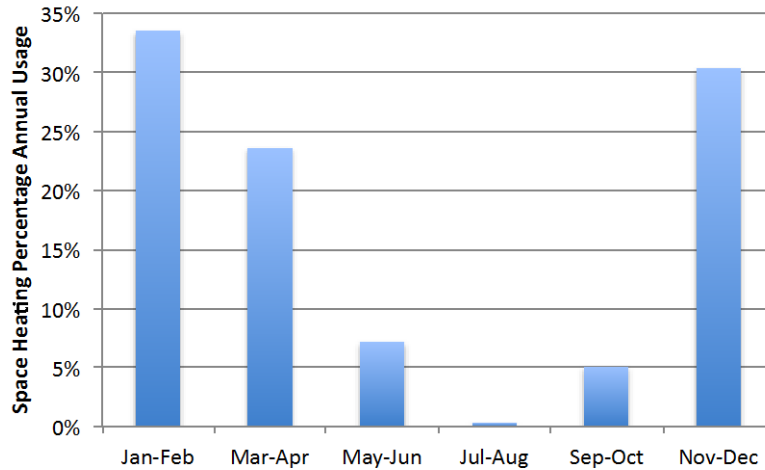
**Figure 4.4. Residential energy service demand projections 2010-2050 (top: all end-use except lighting, bottom: lighting).**

## 4.2.2 Temporal resolution of end-use demands

In this section, we explain the temporal resolution of space heating and space cooling, and other end-use services that have annual temporal resolution.

### 4.2.2.1 Space heating

Total demand for space heating is allocated over a year by specifying the fraction of residential space heating demand for each time slice, i.e., bi-monthly temporal resolution. The fraction is calculated based on the total number of heating degree days (HDD) in each 2-month interval averaged over 2008, 2009 and 2010 (Figure 4.5).<sup>7</sup>



**Figure 4.5. Shares of heating demand in a given year for the seasonal time slice (by-monthly) used in CA-TIMES.**

### 4.2.2.2 Space cooling

Residential cooling demand varies by time of day and by season, and contributes significantly to electricity peak energy demand during late afternoon in summer months. The hourly cooling demand is based on McCarthy et al. (2008), which is derived from the hourly electricity demand profile by utility planning area for California in 2003 and assumed to be constant to 2050. The hourly demand for all 8,760 hours is modeled in CA-TIMES using eight daily (every three hour intervals) and six seasonal (average of every two months) time slices as shown in Table 4.8. We assume this profile will remain the same throughout our modeling period.<sup>8</sup>

---

<sup>7</sup> National Oceanic and Atmospheric Administration (<http://lwf.ncdc.noaa.gov/oa/documentlibrary/hcs/hcs.html>).

<sup>8</sup> In our scenario analysis, we explore the possibility of demand response to various demand management tools such as time-of-day pricing, smart grid, etc. These will be discussed separately in the scenario analysis and the Results chapters.

**Table 4.8. Seasonal and hourly profiles of residential cooling demand modeled in CA-TIME time slices.**

Numbers represent the fraction of a year and the total fraction adds up to 1, numbers at the bottom show the demand fraction in each two months.

Residential	Jan/Feb	Mar/Apr	May/June	Jul/Aug	Sep/Oct	Nov/Dec
T1 (0 -3 am)	0.000	0.002	0.018	0.048	0.014	0.001
T2 (3-6 am)	0.000	0.002	0.017	0.042	0.014	0.001
T3 (6-9 am)	0.000	0.003	0.022	0.052	0.018	0.001
T4 (9 am-12 pm)	0.000	0.003	0.026	0.069	0.021	0.001
T5 (12-3 pm)	0.000	0.003	0.029	0.089	0.024	0.001
T6 (3-6 pm)	0.000	0.003	0.033	0.104	0.028	0.001
T7 (6-9 pm)	0.000	0.004	0.037	0.102	0.031	0.002
T8 (9pm-12 am)	0.000	0.003	0.029	0.076	0.022	0.001
	0.2%	2.3%	21.1%	58.2%	17.2%	0.9%

#### 4.2.3 Characteristics of end-use technology

Typically, six to eight input parameters are used to characterize a demand technology: stock, efficiency, availability factor, lifetime, year of which the technology becomes available, capital cost, operating and maintenance (O&M) cost, and discount rate. Table 4.9 lists the parameters we use to describe technology characteristics. All technology characteristics are assumed to be the same for single and multi-family homes with few exceptions. These parameters are explained in greater detail below.

**Table 4.9. Technology parameters describing residential end-use technologies.**

Parameter	Description	Unit
Stock	Existing capacity	000 units
AF	Availability/utilization factor, relating a unit of production (process activity) in a timeslice (hour/seasonal/annual) to the current installed capacity	TJ/unit/yr, Billion-lumens/unit/yr for lighting
EFF	Energy efficiency	Unitless for all service demands except lighting which is billion-lumens/PJ.
CEFF	Commodity-based efficiency	Unitless. Used only for technologies with more than one service demand (e.g., heat pump technology provides heating and cooling demand that has different efficiencies)
INVCOST	Investment cost in new technology	2010 million\$/000 units for most technologies, 2010 million\$/m-lumens-hrs/yr for lighting
FIXOM	Annual fixed O&M cost	2010 million\$/000 units /yr
Life	Lifetime of new technology	Years
DISCRATE	Technology-specific discount rate (hurdle rate) <sup>9</sup>	%

##### 4.2.3.1 Efficiency

The efficiency of technologies is defined as energy delivered/energy input for all of service demands and Billion-Lumens/PJ for lighting. The definitions of different efficiency metrics are shown in Table 4.10. They are further tied with end-uses in Table 4.11.

**Table 4.10. Definitions of efficiency of end-use technologies**

AFUE	Annual fuel utilization efficiency	Efficiency rating based on average usage, including on and off cycling, it is a thermal efficiency measure of combustion equipment like furnaces, boilers, and water heaters.
------	------------------------------------	---

<sup>9</sup> “Hurdle” rates, or technology specific discount rates, is used to represent non-economic, behavioral aspects of investment choices (e.g., consumer preferences, expectation of very rapid rates of return, or information gaps).

COP	Coefficient of performance	The ratio of the heating or cooling provided over the electrical energy consumed.
EER	Energy efficiency ratio	The ratio of output cooling (in BTU/h) to input electrical power (in watts) at a given operating point.
EF	Energy factor	Total energy consumed in active, cycling, and standby modes.
HSPF	Heating seasonal performance factor	The total heating output of a heat pump in Btu during its normal annual usage.
SEER	Seasonal energy efficiency ratio	The rating of a unit is the cooling output during a typical cooling-season divided by the total electric energy input during the same period.

**Table 4.11. Efficiency metrics describing residential end-use technologies.**

End-Use	End-Use Equipment	Efficiency Metric
Space heating	Heat pump, wood stove	COP [HSPF/3.412], unitless
	Electric furnace, electric radiator	COP, unitless
	Fuel oil boiler/radiator/furnace, kerosene furnace, LPG furnace, natural gas boiler/radiator	AFUE, unitless
Space cooling	Heat pump, air conditioner	COP [SEER/ 3.412], unitless
	Ground-source heat pump, natural gas heat pump	EER
Water heating	Water heater	EF, unitless
Cooking	Range (electric)	Kilowatt-hours per year (kWh/yr)
	Range (other fuel type)	Thermal Efficiency (Btu Out / Btu In)
Clothes drying	Clothes dryer	EF
Clothes washing	Clothes washer	kWh / cycle (motor), Modified Energy Factor <sup>10</sup> , Water Factor <sup>11</sup>
Dishwashing	Dishwasher	EF, Water Factor
Refrigeration	Refrigerator	kWh/yr (In CA-TIMES, we normalize energy consumption to 2010 level, i.e., EFF =1 in 2010)
Freezing	Freezer	kWh/yr (In CA-TIMES, we normalize energy consumption to 2010 level, i.e., EFF =1 in 2010)
Lighting	Light bulbs	Billion lumens/TJ/yr

Heat pump technology (electric, natural gas or geothermal) generates both heating and cooling demand. Even though heat pump is a single unit, cooling efficiency is higher than heating efficiency. Thus the efficiency and capital cost of heat pumps are estimated separately for heating and cooling as if they are two separate technologies in order to compare with other competing heating and cooling technology.

Lighting technologies are divided into four main categories of bulb type: general service (compact fluorescent lamp, incandescent lamp and LED lamp), reflector, linear fluorescent, and torchiere. For the existing stock it is assumed that 50% of used technologies are regular lamps and the other 50% are efficient bulbs.

#### 4.2.4 Calibration to 2010

The technology stock and efficiency are calibrated to final energy demand in 2010. The majority of the data sources for the base year calibration are based on 2005 Residential Energy Consumption Survey (EIA 2008), 2009 Residential Energy Consumption Survey (U.S. EIA 2012), and CEC AEP scenario by

<sup>10</sup> It counts the amount of dryer energy used to remove the remaining moisture content in washed items, in addition to the machine energy and water heating energy of the washer.

<sup>11</sup> The number of gallons per cycle per cubic foot that a washer uses.



McCarthy, Yang et al. (2008) and further extrapolation. Future projections of technology type, fuel type, efficiency, capital cost, and capacity factors are based on “Residential Technology Equipment Type” file obtained from the EIA, which is by the Energy Information Administration for the National Energy Modeling System (NEMS) model for the AEO 2013 projection (EIA 2013).

The technology efficiency, stock, and estimated final energy demand for 2010, and assumptions for future technology are provided in the accompanying spreadsheet. Figure 4.6 shows the final energy demand of residential sector in 2010. Similar to transportation and commercial sectors, future residential technology adoption and fuel uses are projected endogenously based on the assumptions of technology costs, efficiency, fuel uses and other characteristics described in Section 4.2.3, and various constraints such as efficiency standards and the interactions with the rest of the system (e.g., fuel prices and an economy-wide carbon cap).

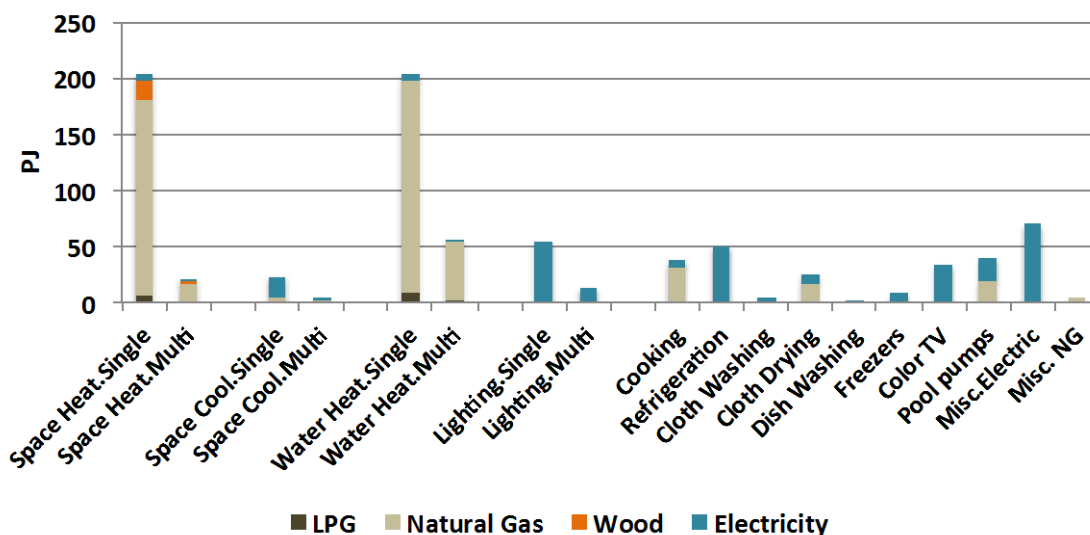


Figure 4.6. Calibrated residential end- use by fuel type, 2010.

#### 4.2.5 Levelized cost and growth constraints

Technology levelized cost (in 2010M\$/PJ) is calculated based on the following equation:

$$\text{Levelized Cost} = (\text{Investment Cost} \times \text{CRF} + \text{O \& M Cost}) / \text{AF} + \text{Fuel Cost} / \text{Eff} \quad (\text{Equation 4.4})$$

Where,

<i>Investment Cost</i>	Technology capital cost (2010 M\$/1000 units),
<i>CRF</i>	Capital recovery factor, $\frac{1}{(1+r)} \times \frac{r}{1-(1+r)^{-life}}$ ,
<i>O&amp;M Cost</i>	Fixed O&M (2010M\$/1000 Units/yr),
<i>AF</i>	Availability factor (TJ/Units/yr),
<i>Fuel Cost</i>	Fuel cost (2010M\$/PJ),
<i>Eff</i>	Efficiency,
<i>r</i>	Technology-specific discount rate (hurdle rate), %,
<i>Life</i>	Economic lifetime of technology.

The levelized costs of different end-use technologies are summarized in Appendix C.

Given the typical all-or-nothing behavior of the optimization model, we added growth constraints to the growth rates of technology penetration over time. We assumed that in each year existing technologies can have an up to 5% growth rate per year, while new technologies that do not have any share in the base year stock can grow up to 20% each year. We put these constraints in order to smooth out the transition to avoid a specific technology taking over the entire market over a very short period of time.

### 4.3 Commercial End Use Sector

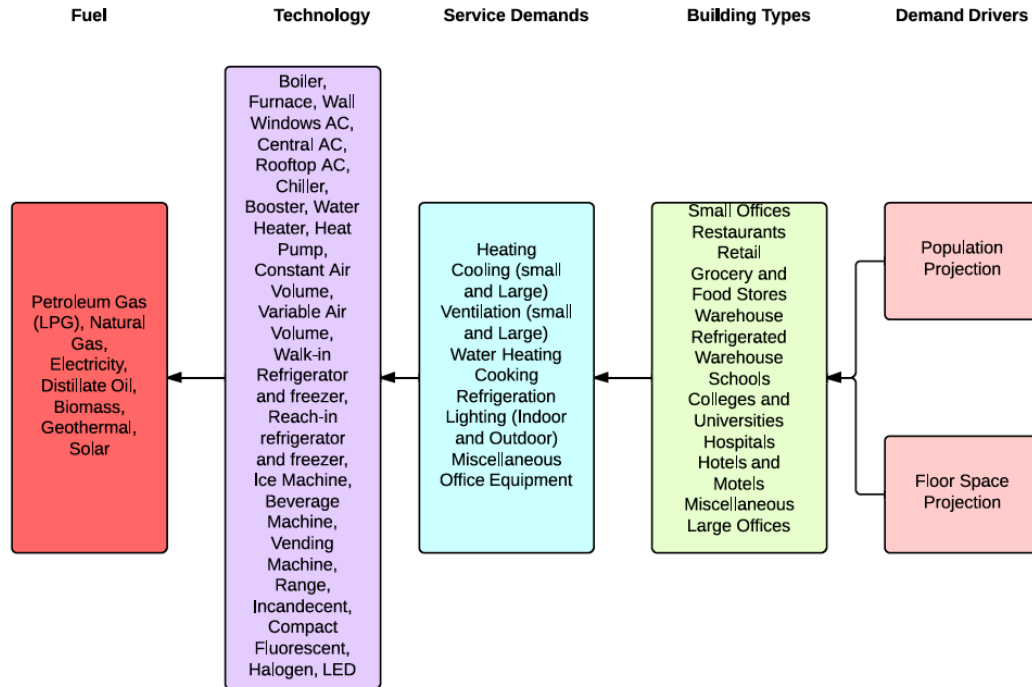
The commercial sector contributes about 4% of total state’s GHG emissions (Figure 1.2). Like the transportation and residential sectors, the commercial sector is modeled through detailed technology options, and the model endogenously estimates technology adoptions and final energy uses over the modeling period.

Commercial sector energy consumption per square foot in California has shown a steep reduction since the 1980s and has been lower than other states. This decline is due to the efficiency standards, building codes, and California’s climate (Bernstein, Lempert et al. 2000). In order to model energy usage of commercial sector we break this sector into 12 building types and each of these buildings has a demand for 9 different end-use energy services, which are shown in Table 4.12.

**Table 4.12. Commercial building types and end-use energy services.**

<b>Building Types</b>	<b>End-use energy service</b>
Small Offices	Heating
Restaurants	Cooling (small and Large)
Retail	Ventilation (small and Large)
Grocery and Food Stores	Water Heating
Warehouse	Cooking
Refrigerated Warehouse	Refrigeration
Schools	Lighting (Indoor and Outdoor)
Colleges and Universities	Miscellaneous
Hospitals	Office Equipment
Hotels and Motels	
Miscellaneous	
Large Offices	

Many end-use technologies can be used to satisfy each end-use service demand, like walk-in refrigerators, central ACs, heat pumps, etc. This wide range of technologies consumes fuels such as natural gas and electricity and has various efficiency levels and costs. The schematic diagram of commercial sector in CA-TIMES is shown in Figure 4.7.



**Figure 4.7. Structure of energy demand and supply for CA-TIMES v1.5 commercial sector.**

Our model endogenously chooses the least cost available technologies based on economic factors and policy constraints to satisfy commercial end-use service demands over time. Final energy demand is also calculated endogenously according to efficiencies of projected technology adoption.

We use estimates of 2010 electricity and natural gas usage by commercial end-use energy service demand and building type from IEPR report (CEC 2011). This energy use data by fuel type is combined with data from National Energy Modeling System (NEMS), which supplies the mix of technologies that is used to meet energy service demand for the Pacific region for 2012. The technologies used in region 9 (Pacific region) are assumed to be representative of California technologies, and the technology mix from 2012 is assumed to be representative of the 2010 mix.

Combining fuel usage and the mix and efficiency of technologies, we back calculate the energy-service demand using Equation 4.5, where energy service demand for a given end-use (e.g., cooling or heating)  $j$  is equal to the fuel demand scaled by the weighted technology efficiency values (by technology market share) over all technologies,  $i$ .

$$Energy\ Service\ Demand_j = \frac{Electricity\ Demand_j}{\sum_i \left( \frac{TechMktShr_i}{\eta_i} \right)} + \frac{Natural\ Gas\ Demand_j}{\sum_i \left( \frac{TechMktShr_i}{\eta_i} \right)} \quad (\text{Equation 4.5})$$

where  $\eta_i$  is the efficiency of technology  $i$ .

For projecting the end-use service demand to 2050, we assume that the energy service demand is constant per square foot for a given building type, i.e., the cooling demand (not energy use) per square foot is constant for a grocery store to 2050. The changes in aggregate energy service demand are a result of changes to floor space of each building type. These energy service demands are aggregated over all building types and an annual projection of energy service demands is made.

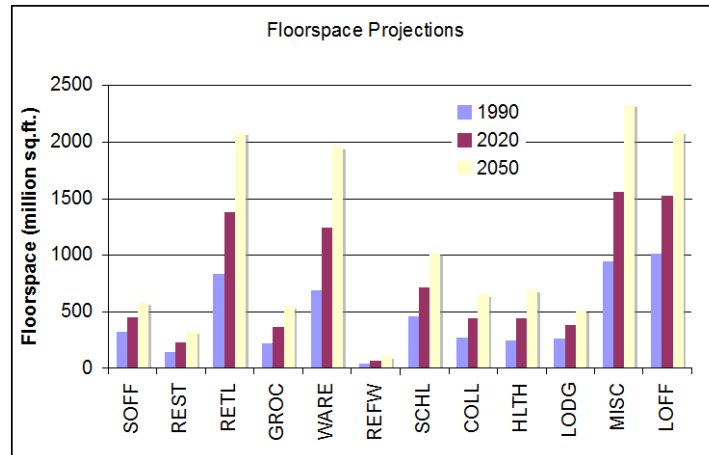
$$Energy\ Service\ Demand_{total} = \sum_j (Floorspace_j)(Energy\ Service\ Per\ SqFt_j) \quad (\text{Equation 4.6})$$

where  $j$  is the building type.

The CEC report (2009) provides historical and projected commercial floor space for each of the 12 building types from 1964 to 2020. We extrapolate the floor space per capita trend from 1990 to 2020 out to 2050. The annual change in floor space per capita ( $F/cap$ ) for a given building type ( $i$ ) is calculated by the following:

$$\Delta F / cap_{i,ann} = \frac{F / cap_{i,2020} - F / cap_{i,1990}}{30} \quad (\text{Equation 4.7})$$

Total commercial floor space per capita aggregated over all building types increases from 183 sq. ft. per person in 1990 to 200 sq. ft. per person in 2020 to 217 sq. ft. per person in 2050. The total floor space for each building type in a given year is calculated by multiplying the population projection by the floor space per capita projection for a given year. Total commercial floor space increases from 5,453 million sq. ft. in 1990 to 8,816 million sq. ft. in 2020 to 12,892 million sq. ft. in 2050 (Figure 4.8).



**Figure 4.8. Floor space projection by building type.** SOFF: Small Offices, REST: Restaurants, RETL: Retail, GROC: Groceries, WARE: Warehouses, SCHL: Schools, HLTH: Hospitals and Health, LODG: Hotels, REFW: Refrigerated warehouses, MISC: Miscellaneous, LOFF: Large Offices.

The projected commercial end-use service demand based on the given explanation is shown in Figure 4.9.

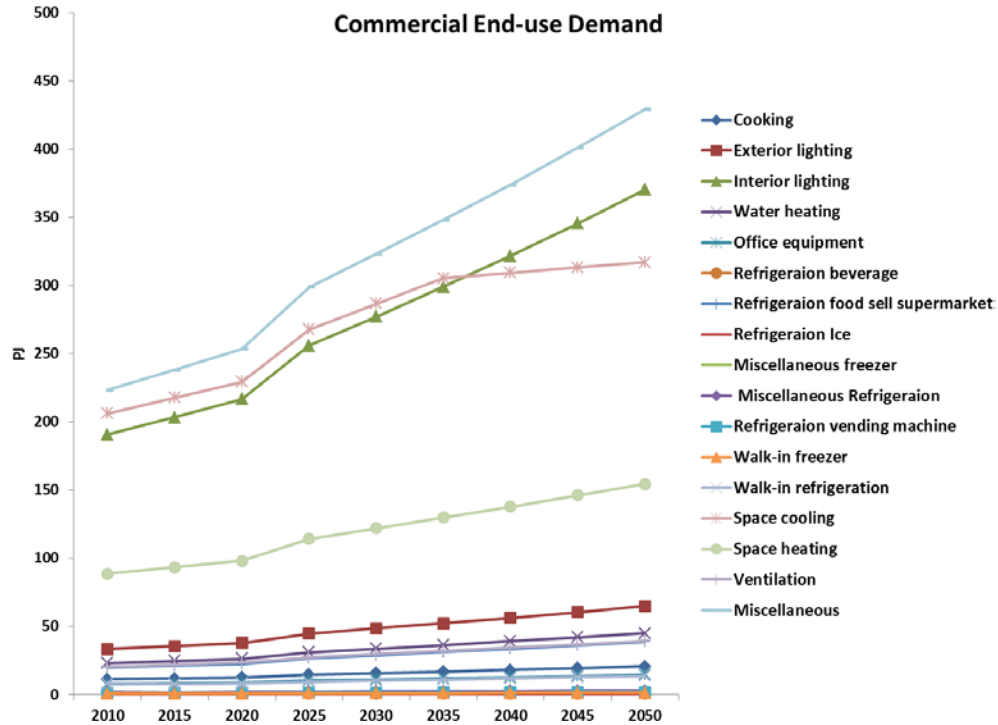
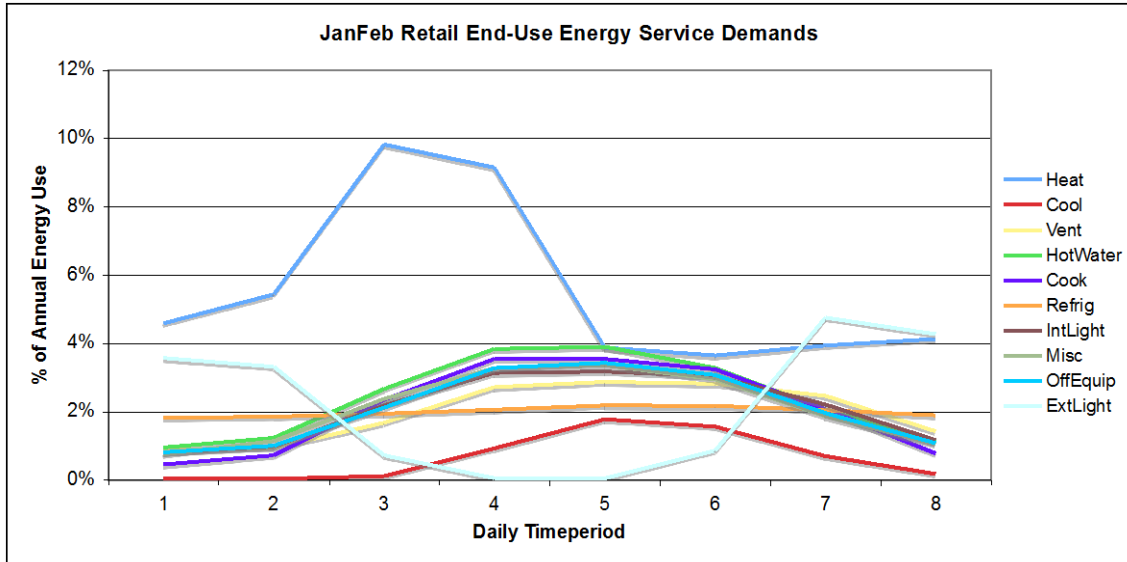


Figure 4.9. Commercial service demand projected to 2050. Note: most service demands are in PJ, but lighting and ventilation service demands are in different units (billion lumen-yr and trillion CFM-yr).

### 4.3.1 End-use demand by time slice

ITRON data prepared for the California Energy Commission is used to break out energy demands by building type and end-use into fractional energy use by time slice (ITRON 2006). The original data gives end-use demands for each hour of the year by building type, end-use demand and fuel. This data is aggregated to combine different fuel types and to obtain data that fit into our 48 time slices, as described in earlier chapters (8 daily time slices for every 3-hr interval, and 6 seasonal time slices for every 2-month interval). The data gives details of the fraction of annual energy use that occurs in a given time slice for each building type and end-use demand.

Figure 4.10 shows a small subset of the data: how energy service demands vary over the course of the day (in Jan and Feb) for retail commercial buildings. Most demands follow the same daily pattern with the maximum demand in time periods 4 through 6 (noon to 6 pm) and low at night. Exceptions are refrigeration (constant) and heating and external lighting (peak in early morning and at night, respectively).



**Figure 4.10. Daily variation of service demand for retail commercial building in January and February.** The daily time period is grouped into three-hour time slices. Thus the daily time period 1 corresponds to 12 am-3 am, and so on.

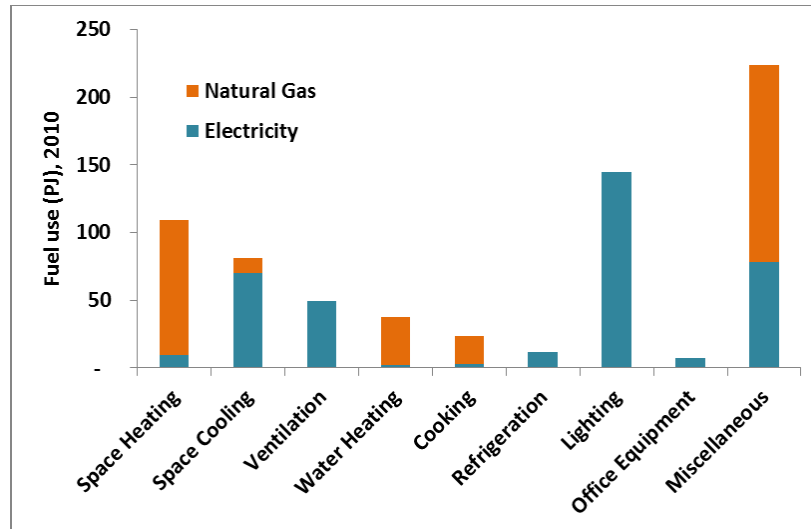
### 4.3.2 Technology characteristics

We use six to eight input parameters to characterize a demand technology in commercial sector. These parameters are described in Table 4.13.

**Table 4.13. Technology parameters describing commercial end-use technologies.**

Parameter	Description	Unit
Demand	Demand for energy service	PJ/yr; billion lumens hours/year for lighting; trillion cubic feet (TCF) per year for ventilation
Stock	Existing installed capacity	PJ/yr; billion lumens/yr for lighting; TCF/year for ventilation
AF	Annual availability/utilization factor	Unitless.
EFF	Technical efficiency	PJ/PJ; billion lumens years/PJ for lighting; TCF per minute (TCFM)/PJ for ventilation
CEFF	Commodity-based efficiency	PJ/PJ for heat pumps
INVCOST	Total cost of investment in new capacity	2010 Million\$/PJ (2010 Million\$/b-lumens for lighting and 2010 Million\$/TCFM for ventilation)
FIXOM	Annual fixed O&M cost	2010 Million\$/PJ/yr (2010 Million\$/b-lumens yrs for lighting and 2010 Million\$/TCFM for ventilation)
Life	Lifetime of new technology	Years
DISCRATE	Technology-specific discount rate (hurdle rate)	%

Energy consumption and floor space projection data come from CEC reports (CEC 2009, CEC 2011). Assumptions of technologies are based on “ktek.xml” file obtained from the EIA, which is used for the National Energy Modeling System (NEMS) model for the AEO 2013 projection (EIA 2013). Our model is calibrated to the year 2010. The final energy consumption by end-use service demand is shown in Figure 4.11. Additionally, levelized costs of commercial sector technologies are calculated similar to residential sector, and they are documented in Appendix C.



**Figure 4.11. Commercial fuel use by end use, 2010.**

Similar to the residential sector, the commercial sector is calibrated to the year 2010. For the projection of future technology adoption, growth rates are added as explained in the residential sector. Similar to the residential sector, we assume that technologies with existing stock can only grow up to 5% each year, while new technologies that do not have any share in the base year stock can grow up to 20% each year.

#### 4.4 Industrial Sector

The industrial sector contributes to 20% of the state’s GHG emissions (Figure 1.2). The current version of the CA-TIMES model has a fairly simple representation of end-use energy consumption in the industrial and agricultural and other non-energy (Section 4.5) sectors. In this version (v1.5) of the model, we represent final energy consumption in the industrial sectors with generic input-output technologies, as illustrated in Figure 2.1. An input-output technology consumes exogenously specified quantities of various types of fuel in each year. In other words, both the supply of final energy and the demand for total useful energy are specified in energy units (e.g., PJ) and they are equal to each other, i.e., the efficiency of each of the generic input-output technologies is set at 100%. Total useful energy demand and the breakdown of final energy by fuel type are calibrated to published energy statistics for the base-year 2010, using the fuel use estimates of the CARB GHG Inventory (CARB, 2010b). Obviously, given this rigid framework, the model is not free to make fuel use and investment decisions by trading off the costs, emissions, and efficiencies of competing end-use technologies (e.g., boilers, furnaces, CHP, etc.), as it is able to do in the supply and other end-use sectors. However, while most model runs in this report use these fixed specified fuel demands, operation of the CA-TIMES model with the elastic demand framework does partially allow for feedback and interplay with the other sectors, since in this model configuration of the fuel demands are price elastic thus changes of price/quantity in other sectors in response to policies will also affect the fuel use demand in the industrial sector, albeit in a much more non-transparent (and pure econometric) fashion.

Fuel use demands in the Reference Case are drawn heavily from the California Energy Commission and UC-Davis Advanced Energy Pathways (AEP) project (McCarthy, Yang et al. 2008); while fuel use changes under the Deep GHG Reduction Scenario are largely based on the magnitude projected in the BLUE Map scenarios of the IEA’s Energy Technology Perspectives (ETP) 2010 study (IEA 2010). Figure 4.12 shows the exogenously defined industrial energy demand in the BAU and GHG scenarios. Total demand for industrial energy in the GHG scenarios is 13% lower in 2050 and has a significant shift towards the use of electricity (from 30% to 80%) compared with the BAU scenario.

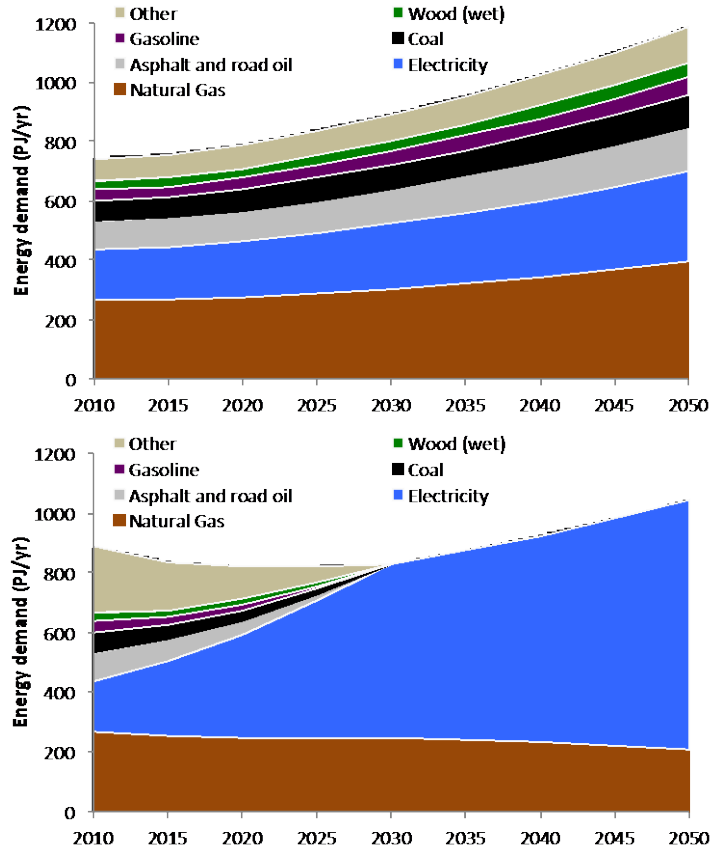
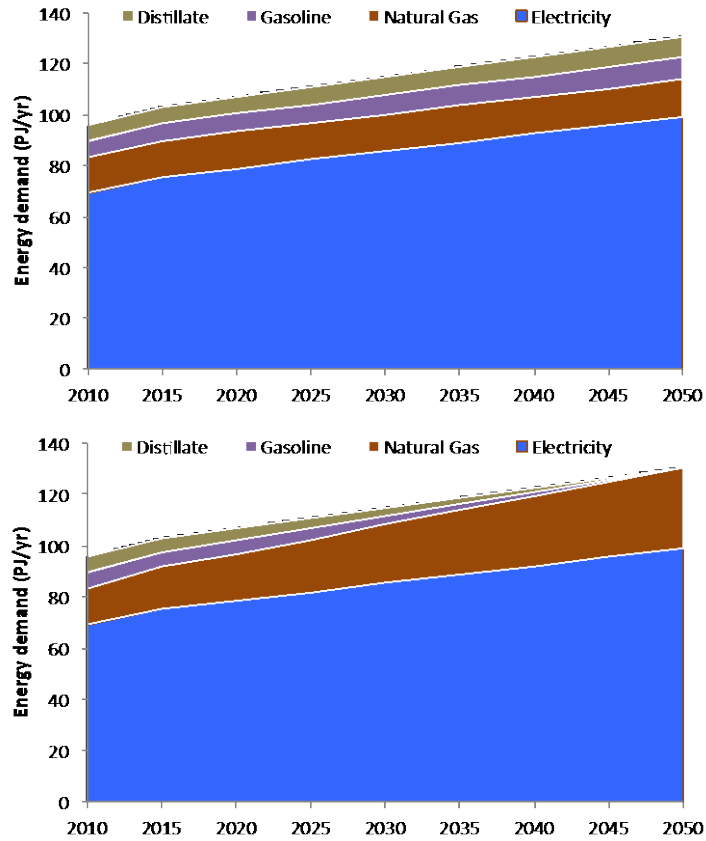


Figure 4.12. Industrial final energy demand assumed in the BAU (top) and GHG policy (bottom) scenarios.

#### 4.5 Agricultural and Non-Energy Sector

The smallest of California’s end-use energy sectors is agriculture. It accounts for only 1.6% of the state’s total energy demand, despite the fact that agriculture plays such an important role in California’s economy and society. It is important to note that the fuel consumption in agricultural vehicles is not included here, but rather in the transportation sector. Most energy use in the agricultural sector is used to operate pumps, lighting and other farm/fishery equipment. Yet, even if energy demands for agricultural vehicles were included, total energy demand for the agricultural sector would still only amount to 2.3% of all end-use energy consumption in California. Like the industrial sector, energy service demands are not modeled with endogenous technology adoption. Rather, a scenario was developed to represent final energy consumption in the agricultural sector with generic input-output technologies. Figure 4.13 shows the exogenously defined agriculture energy demand in the BAU and GHG scenarios. Electricity makes up the majority of agricultural energy use (since we are excluding vehicles) and the major shift for the GHG scenarios is the assumption that petroleum based fuels are replaced with natural gas.





**Figure 4.13. Agriculture final energy demand assumed in the BAU (top) and GHG policy (bottom) scenarios.**

Non-energy sector GHG emissions (accounting for around 13% of emissions in the base year) are not included in CA-TIMES model at the present time. In the deep GHG scenarios, it is assumed that these emissions are also controlled to a similar extent as combustion related emissions.

## 5. SCENARIOS

One of the main values of the CA-TIMES model is to run the model with varying sets of technology, resource and policy-related inputs and analyze the results to understand which options the model chooses as the optimal solution to satisfy the energy service demands. These scenarios, as we will define below, can result in a very different mix of technologies and resources in the optimal solutions.

There are a number of choices that are made when running a specific scenario, and these choices will impact the modeling results: technology mix, system costs, and emissions profile. Table 5.1 shows a list of generic choices that need to be made when developing a scenario.

**Table 5.1. List of choices that define a scenario’s inputs and influence the optimization model results.**

Category	Examples of Scenario Variants
<b>Demand</b>	Energy service vs. fuel demands Inelastic vs. elastic demands Varying levels of forecasted demand <i>e.g., VMT, residential space heating, industrial electricity use</i>
<b>Technology</b>	Technology cost trajectory (over time) Technology growth constraints Technology share constraints
<b>Resource</b>	Resource cost (over time) Resource availability and limitations (over time) Supply curve vs. price/cost trajectory Intermittent renewable availability <i>e.g., in-state biomass supply curves, wind speed profile</i>
<b>Policy</b>	Technology subsidies Technology mandates or bans <i>e.g., Zero Emission Vehicles (ZEV) mandates</i> Performance standards <i>e.g., Renewable Portfolio Standard (RPS), Low Carbon Fuel Standard (LCFS)</i> Pollution taxes or caps <i>e.g., carbon cap, biofuel volume mandate, prohibition on nuclear</i>

Many of the technology options are described in earlier sections covering each sector (transportation, electricity, residential and commercial). This section will focus primarily on policy and technology choices that influence the least-cost pathways for reference (BAU) futures (which do not attempt to mitigate GHG emissions beyond currently implemented policies) and futures that attempt to achieve the state’s target of an 80% reduction in GHG by 2050. The goal of this section is used to understand how the California energy system could be significantly decarbonized in the long term, what the technological and resource implications might be in such a case, and how much the energy system transition could cost. Several GHG scenario variants are analyzed in which policies, technology and resource availability, and technology and resource costs are varied, in order to understand how the transition to a low-carbon economy in California could be different if the potential of certain technologies and resources is substantially restricted or enhanced.

### 5.1 Reference Scenario

The CA-TIMES Reference Case (often designated as “BAU” scenario) is a scenario describing the potential development of California’s energy system over the next several decades under the business-as-usual (BAU) conditions. It is best interpreted not as a prediction of what will happen between now and 2050, but rather a single vision of what *could* happen, if the technological and policy assumptions in the model were to come to fruition and the various decision makers within society (e.g. consumers, firms and

governments) behaved in a manner that minimizes societal costs given the policy, resource, economic and behavioral constraints that we specify in the model. While in other applications such as the Intergovernmental Panel on Climate Change (IPCC), a number of Reference Case scenarios could be developed (O’Neill, Kriegler et al. 2014), our report chose to focus on one or two BAUs to keep the comparison manageable. The Reference Case is the scenario to which all other scenarios, especially the deep GHG reduction scenarios, are compared.

The following section illustrates the development of the energy system in the Reference Case. It hopefully provides a sense for how the system could potentially develop in the absence of any substantial effort to make a transition in California toward a low-carbon society beyond 2020.

The reference scenario has a baseline level of energy service and fuel demands that are taken from multiple sources, including VMT projections from EMFAC 2011 (CARB 2011), industrial and agricultural fuel demands from (McCarthy, Yang et al. 2008) and residential and commercial energy service demands are based upon population, household and floorspace projections from numerous sources. These assumptions are explained in greater details in Sections 3 and 4.

### 5.1.1 Reference scenario policies

Policy is an important driver of energy system development. And while the previous sections have discussed the most important resource, technology, and demand assumptions – and their respective data sources – used to develop the CA-TIMES Reference scenario, the Reference scenario is also strongly dependent on current policies and how they are assumed to develop over time.

Table 5.2 lists the policies represented in the Reference scenario. Although it is not possible to represent every single policy that affects California’s energy system, the list below attempts to capture those of greatest importance and with the largest impact. A more detailed description of each of these policies, and how it is modeled, is given in Appendix D.

**Table 5.2. Brief descriptions of policies represented in the CA-TIMES v1.5 reference scenario.**

<i>Scenario</i>	<i>Policies</i>
<i>Reference</i>	<ul style="list-style-type: none"> <li>- Current biofuel tax credits</li> <li>- Current biofuel import tariffs</li> <li>- Current transportation fuel taxes</li> <li>- CAFE standards to 2016 (39.5 mpg and 29.8 mpg for cars and trucks, respectively)</li> <li>- CAFE standards to 2025 (59.8 mpg and 45.1 mpg for cars and trucks, respectively)</li> <li>- Federal and California electric vehicle subsidies</li> <li>- Low carbon fuel standard (LCFS) biofuel volume <i>scenario</i><sup>12</sup> to 2022 (retired after 2022)</li> <li>- Power plant electricity GHG standard (baseload must meet NGCC emissions)</li> <li>- Renewable portfolio standard (33% by 2020 and remains at 33% until 2050)</li> <li>- Renewable electricity production tax credit, solar investment tax credit</li> <li>- Zero Emission Vehicle (ZEV) mandate policy <i>constraint</i> to 2025 (retired after 2025)</li> <li>- No new nuclear power plants (and retirement of SONGS by 2030)</li> </ul>

---

<sup>12</sup> The LCFS policy shown here is a scenario that defines a single or limited sets of fuel options that will satisfy this policy, rather than a more realistic and flexible representation of the policy that can be met with multiple fuel mixes. The assumptions of the LCFS scenario are detailed in Appendix D. A more realistic performance-based LCFS policy scenario has been set-up, but was not available in time for incorporation into this version of the model.

There are a number of current policies that have not been incorporated into the reference case, SB1505, SB375 and the Federal heavy duty GHG rule. These may be incorporated into future iterations of the model.

Running the Reference scenario in the CA-TIMES model, as with all scenarios, leads to the optimization of the energy system that can meet the specified demands for energy services within California to 2050 in the least cost manner, subject to the specified resource, policy, and other behavioral or user constraints (e.g., growth constraints and hurdle rates). This energy system will have a specified cost and emissions trajectory as well as technology and resource mixes that will be compared to the policy (GHG reduction) scenarios.

## **5.2 Greenhouse Gas Scenarios**

The GHG Reduction Scenarios describe a number of different futures in which the California's energy system undergoes substantial decarbonization over the next several decades in the context of a social, political, and economic framework that first recognizes and then acts to mitigate the threat of climate change, both within California and in the rest of the U.S. and the world. Hence, individuals, firms, and governments all make substantial efforts to make a transition in California toward a low-carbon society. Again, these scenarios should not be mistaken as predictions of what will happen as a result of strong climate policy, but rather as individual visions of what *could* feasibly happen, under the large set of technological and policy assumptions embedded in the model. The probability of any single scenario result occurring is essentially zero. However, their value is in understanding the role that technology and resource costs and availability and policy can play in influencing the development of the future energy system to 2050.

Because CA-TIMES is run as a deterministic model, any suite of inputs will lead to a specific model result and thus, alternative scenarios are generated by running with variations in model inputs. While a large number of these GHG scenarios can be developed (as there are tens to hundreds of assumptions that are connected to the thousands of technologies embedded in the model, each of which can be varied), a limited number will be discussed here. An overriding theme to these GHG scenarios is that they attempt to achieve an 80% reduction in GHG emissions below 1990 levels by 2050. Multiple GHG scenarios are developed that investigate interesting variants of this core goal, where changes in demand assumptions or the availability of key resources and technologies is altered.

### **5.2.1 Greenhouse Gas Scenarios Policies**

Policy is the most important driver for inducing dramatic energy system transitions. The GHG scenarios include all policies that are represented in the Reference Case (

Table 5.2), as well as additional policies that would also need to be enacted in order to meet a very stringent GHG target. For example, the state has an aspirational goal of an 80% reduction in GHG emissions below 1990 levels by 2050 (*80in50*), but current policies and regulatory mechanism in place are not enough to achieve the 2050 target (BAU emission trajectory). Market mechanisms such as a cap-and-trade (i.e., emissions trading) program or carbon tax with stringent caps/tax levels would be needed.

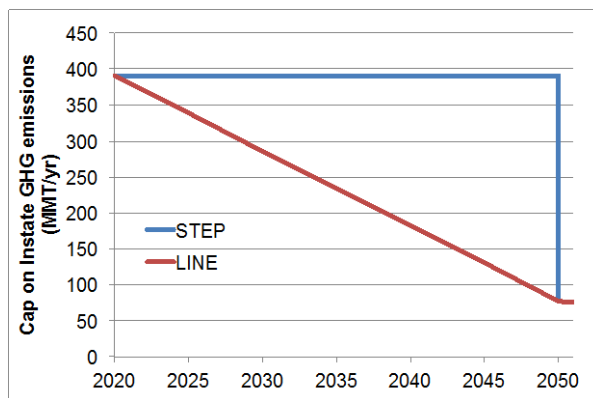
CA-TIMES only tracks emissions from the energy usage, while some GHG emissions listed in the ARB inventory for California for 1990 are not related to the use of energy (non-energy emissions). California's GHG emissions in 1990 for the categories that CA-TIMES tracks are 390.84 MMT CO<sub>2</sub>e (vs 426.59

MMTCO<sub>2</sub>e for the capped sectors of the inventory)<sup>13</sup>. The emissions categories included in the ARB inventory, and used for the purposes of setting the target for AB32 and the 80% reduction target includes out-of-state electricity generation (i.e., imports) but excludes interstate and international aviation and marine emissions. The 80% reduction from 1990 GHG emissions (i.e., the 2050 target) is 78.17 MMTCO<sub>2</sub>e (390.84 MMTCO<sub>2</sub>e × 0.2).

As discussed in section 3.5, CA-TIMES tracks several categories of emissions related to California’s energy usage. The cap on emissions only includes the *Included Instate* emissions which is all fuel and energy combustion and production emissions in the state, plus all emissions associated with electricity generation (even for imported electricity), but excluding interstate and international aviation and marine fuel combustion.

The CO<sub>2</sub> cap used in CA-TIMES fits with the energy-related inventory description as by CARB for AB32. The exclusion of out-of-state aviation and marine emissions makes the cap less stringent as some important emissions sources are not included in the state’s cap. And importantly, these sectors are quite difficult to decarbonize as they are expected to rely primarily on liquid fuels. Because CA-TIMES does not consider non-energy GHG emissions, an 80% reduction target on the energy emissions that it does consider implies that non-energy GHG emissions are also reducing by 80%. If non-energy emissions are easier or more difficult to mitigate, then this would have an important impacts on the ease (and cost) with which the state meets its emissions target.

For simplicity and transparency, two types of constraints to modeling the 80in50 target are used in the CA-TIMES model. The first type of constraint is called the “Step” cap in which a cap is held at the 2020 target (1990 levels) between 2020 and 2050 but then dropped to 80% below 1990 emissions in 2050. The second type of constraint is a declining carbon cap – specifically, a straight-line trajectory from 2020 to 2050 is assumed and called “Line”. Figure 5.5 shows the numerical values for the GHG emissions caps assumed in both constraints. Though the Step emissions cap makes a dramatic reduction in 2050, the actual path of emissions is unlikely to follow this cap because of the difficulty of reducing emissions so quickly in the year(s) before 2050.



**Figure 5.1. Carbon cap by year for the GHG policy scenarios, GHG-Line and GHG-Step.** Both achieve 80% reduction from 1990 emissions levels by 2050.

<sup>13</sup> CA-TIMES ignores approximately 42 MMTCO<sub>2</sub>e of emissions from cement production and other industrial processes, emissions from agriculture and waste treatment and fugitive emissions from oil, gas production, as well as nearly 7 MMTCO<sub>2</sub>e of negative emissions from natural sinks and sequestration.

While a linear cap might be a more likely approach from the state between 2020 and 2050, the “Step” GHG cap model constraint provides maximum model flexibility in terms of the type and timing of investments in low carbon resources and efficient technologies to meet the 2050 target in the least cost manner. Thus, while it is not likely that the State would have no interim GHG targets between 2020 and 2050, it is useful to understand how an optimized future calculated under the “Step” scenario differs with the “Line” scenarios. And the “Step” approach also helps elucidate an “optimized” emission reduction trajectory for setting the interim GHG targets between 2020 and 2050, balancing emissions reductions with minimizing mitigation costs. Note that the “optimized” emission reduction trajectory under the “Step” scenario has the following caveats:

- *Emissions instead of impacts:* Consistent with state policies, the model only considers annual emissions targets rather than focusing on minimizing temperature change (or other effects of climate change) that are determined primarily by cumulative emissions. Due to the long residence time of many of the GHGs, earlier reductions can achieve greater reductions in climate impacts than later reductions for the same level of annual emission in 2050.
- *Discount rate:* Using a discount rate values present costs more than future costs. With respect to the trajectory of emissions reductions, the discount rate will affect the timing of emissions reductions, with higher discount rates leading to greater incentives to delay high-cost investments in mitigation. We use a 4% discount rate in CA-TIMES.
- *Endogenous learning:* Because CA-TIMES has exogenous cost assumptions as a function of time, investments in a technology do not stimulate further cost reductions. With endogenous technological learning (ETL), early investments in GHG mitigation can lead to lower costs because investments in low-carbon technologies would lead to further cost reductions. When technology costs decline only as a function of time (as in CA-TIMES), rather than because of ETL, system costs are minimized when investments are delayed until technology costs decline.

Beyond the carbon constraint, there are no other policies that are included in all of the GHG Scenarios that are not included in the Reference case. In the GHG scenarios, VMT reductions are implemented for many transport sectors, which correspond to a suite of strong travel demand management (TDM) policies dealing with transit, land use, and auto pricing. These lead to a reduction in light-duty vehicle (LDV) VMT by 24%, and heavy-duty vehicle (HDV) and medium-duty vehicle (MDV) VMT by 10% in 2050 relative to the Reference case. Also, passenger automobile share of the light duty vehicle market is expected to climb to 75% in the GHG scenarios (the baseline share in the Reference case is 65%).

A separate Reference scenario is also run that takes into account these lower VMT activities (BAU-LoVMT) in order to provide additional points of comparison for the GHG scenarios. Since in general, VMT reduction leads to a large cost savings (from purchasing fewer vehicles and using less fuel), comparing BAU-LoVMT and GHG scenarios provides a more “fair” way of comparing an alternative future where VMT reductions are caused by factors other than climate policies, such as changes in social attitudes toward driving or land use policies unrelated to climate policies.

### 5.3 Scenario Variations

The sensitivity scenarios are used to understand the impact of changing input assumptions, technology availability or policy constraints can have on the on the ability of the state to meet the 80in50 target and cost and mix of options used to achieve the GHG reductions. The key sensitivity parameters for the 80% greenhouse gas reduction scenarios that will be discussed are shown in Table 5.3. As with any modeling work, there are many more possible scenarios that would be interesting to explore but could not be run due to time limitations. Future work will explore many more variations on input assumptions, resource availability, and policy constraints, to further explore the sensitivity of CA-TIMES to these model inputs.

**Table 5.3. Sensitivity parameters for GHG scenarios.** “GHG-S” represents scenarios with a “Step” constraint on GHG emissions as described in the previous section, and “GHG-L” represents scenarios with a “Line” constraint on GHG emissions between 2020-2050.

<b>Sensitivity Case</b>	<b>Description</b>
Nuclear power plant availability ( <i>GHG-S-Nuclear</i> )	<b>Base GHG case:</b> Existing nuclear power retired in 2030. No new nuclear power plants allowed <b>Sensitivity case:</b> New nuclear power plants can be built
Carbon capture and sequestration (CCS) availability ( <i>GHG-S-CCS</i> )	<b>Base GHG case:</b> No electricity or fuel plants will use CCS as the technology remains unproven <b>Sensitivity case:</b> CCS is available on many different types of plants
Nuclear power and CCS availability ( <i>GHG-S-NucCCS</i> )	<b>Base GHG case:</b> No new nuclear power plants allowed and no electricity or fuel plants will use CCS technology <b>Sensitivity case:</b> Nuclear power plants and CCS technologies are available
Rapid deployment of wind and solar ( <i>GHG-S-HiRen</i> )	<b>Base GHG case:</b> Wind power growth for CA is limited to 3GW/yr, utility solar is limited to 2.5 GW/yr and distributed solar PV is limited to 1 GW/yr in 2030 (and up to 4 GW, 3 GW, and 1.2 GW/yr in 2050) <b>Sensitivity case:</b> Wind power growth for CA is limited to 4 GW/yr, utility solar is limited to 4 GW/yr and distributed solar PV is limited to 2 GW/yr in 2030 (and up to 6 GW, 6 GW and 3 GW/yr in 2050)
Increased biomass supply ( <i>GHG-S-HiBio</i> )	<b>Base GHG case:</b> Details of biomass supply are specified in Section 3.2, but overall supply is limited to nearly 1800 PJ from California and neighboring states in 2050 <b>Sensitivity case:</b> This scenario assumes that the available biomass supply is double that of the base case at the same costs as in the base GHG case.
High and low oil and gas prices ( <i>GHG-S-HiOilGas</i> ) ( <i>GHG-S-LoOilGas</i> )	<b>Base GHG case:</b> Oil price rises to \$130/bbl in 2030 and \$180/bbl in 2050. Gas price rises \$5.4/MMBTU in 2030 and over \$8/MMBTU in 2050 <b>High Price Sensitivity case:</b> Oil price rises to \$191/bbl in 2030 and \$250/bbl in 2050. Gas price rises to \$7/MMBTU in 2030 and over \$11/MMBTU in 2050 <b>Low Price Sensitivity case:</b> Oil price declines to \$72/bbl in 2030 and \$70/bbl in 2050. Gas price declines to \$3.3/MMBTU in 2030 and over \$3.7/MMBTU in 2050 The cost assumptions are shown in Figure 3.2
Elastic demand ( <i>GHG-S-Elas1</i> ) ( <i>GHG-S-Elas2</i> )	<b>Base GHG case:</b> Demand for energy services in residential, commercial and transportation sectors is fixed <b>Sensitivity case (Elas1):</b> Demand for energy services can be reduced based upon elasticity of demands and endogenous price changes (relative to BAU scenario). This version of elasticity allows for a proportional reduction in the investment in end-use appliances (i.e., vehicles, heaters, light-bulbs) as demand is reduced. <b>Sensitivity case (Elas2):</b> Demand for energy services can be reduced based upon elasticity of demands and endogenous price changes (relative to BAU scenario). This version of elasticity constrains the level of end-use appliances to be equal to the non-elastic scenario even as demand is reduced. This represents the case where consumers may reduce the use of end-use technologies (e.g., less driving, less cooling) but would still purchase the same number of end use technologies (e.g., cars, air conditioner).

## 6. RESULTS

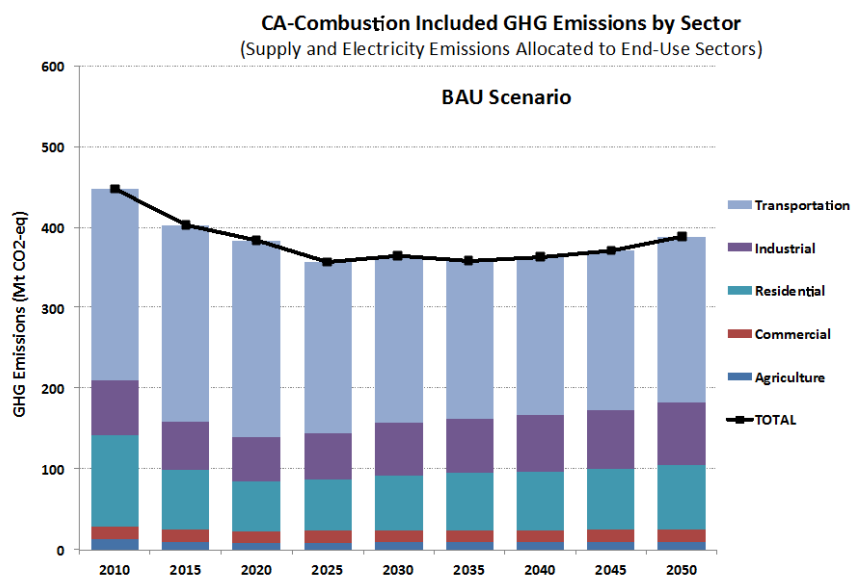
Modeling is a complex, but inexact science and these large energy system models are a simplified representation of reality. CA-TIMES is no exception and scenarios and model structure and assumptions are continually being modified and adjusted. The results shown in this section represent a set of modeling results from CA-TIMES as it stands now (CA-TIMES v1.5).

### 6.1. Primary Scenarios

This section will review the key results from the three primary scenarios: (1) the Reference (BAU) case, (2) the 80% GHG emissions reduction case with the “Step” CO<sub>2</sub> cap (GHG-Step) and (3) the GHG emissions reduction case with the linear “Line” CO<sub>2</sub> cap (GHG-Line).

The in-state GHG emissions for the Reference (BAU) scenario are shown in Figure 6.1. In this scenario, emissions are shown declining from the base year of 2010 to 2025 (from 447 MMTCO<sub>2</sub>e/yr to 356 MMTCO<sub>2</sub>e/yr) and then growing slightly from there (387 MMTCO<sub>2</sub>e per year) to 2050. The 2020 GHG emissions are 383 MMTCO<sub>2</sub>e/yr, below the 2020 target of 390 MMTCO<sub>2</sub>e/yr, even though the AB32 cap on emissions is not a constraint in this Reference scenario. In the graph, emissions from energy supply (i.e., electricity and energy transport, conversion and fuel production) are assigned to the relevant end-use sectors.

In 2050, *Included Instate* GHG emissions are approximately 1% lower than 1990 levels (388 MMTCO<sub>2</sub>e). Emissions from all end-use sectors decline slightly but remain similar in scale to 2010 levels. The largest emissions source remains transportation, which accounts for just over half of in-state emissions and which declines very slightly over the modeling period (237 MMTCO<sub>2</sub>e in 2010 to 204 MMTCO<sub>2</sub>e in 2050). *Overall Instate* emissions (including interstate/international aviation and marine) in the BAU scenario are 437 MMTCO<sub>2</sub>e.



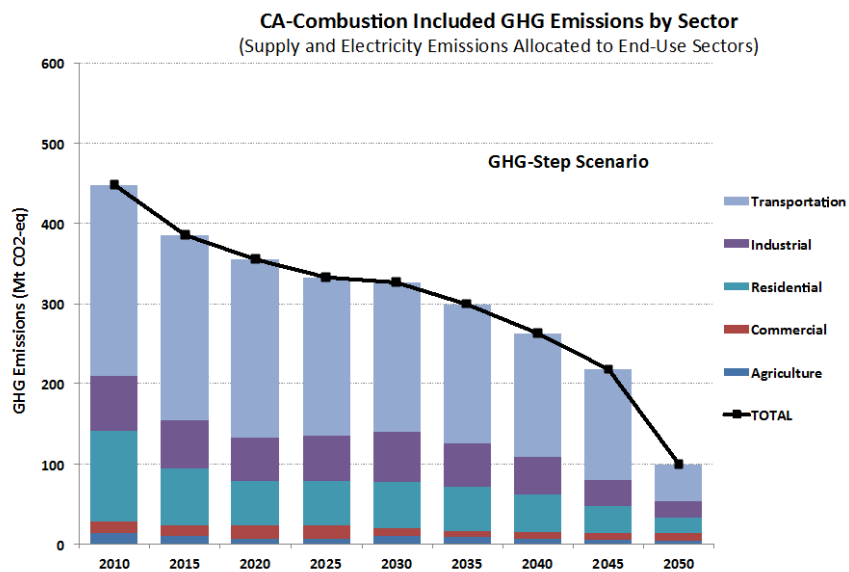
**Figure 6.1. *Included Instate* GHG emissions from 2010 to 2050 by sector for the Reference scenario.** Instate emissions include shipping and aviation emissions not included in the State’s GHG emission inventory.

When the 80% GHG emissions reduction constraint is added, both primary GHG scenarios are not able to meet the 80% GHG reduction target in 2050. Both scenarios are able to reduce *Included Instate* emissions below 1990 levels by 74.6% falling just short (5.4%) of the 80% target. These results must be understood in the context of several important points about our CA-TIMES model: (1) the model only looks at



reducing emissions from energy usage and fuel combustion, and ignores non-energy emissions; (2) emissions and fuel use from cross-boundary aviation and marine trips international are not included in the GHG target, consistent with the state’s treatment of emissions categories; (3) emissions offsets are not included in these scenarios.

In the GHG-Step scenario, even though the emissions cap stays constant at the 2020 target (391 MMTCO<sub>2</sub>e), *Included Instate* emissions decline to about 327 MMTCO<sub>2</sub>e in 2030 and 218 MMTCO<sub>2</sub>e in 2045. The GHG-Step scenario emissions are 99.3 MMTCO<sub>2</sub>e in 2050, 21 MMTCO<sub>2</sub>e above the 2050 emissions target. Transportation continues to provide the largest share of emissions (41 MMTCO<sub>2</sub>e) while emissions from industrial, residential and commercial shrink dramatically. *Overall Instate* emissions in these two GHG scenarios is 161 MMTCO<sub>2</sub>e, or only 64% below 1990 *Overall Instate* emissions. Since the out-of-state transport (interstate/international aviation and marine) emissions are not included in the emissions cap, emissions from these activities are not reduced significantly, though they do not grow significantly either, due to moderate efficiency improvements.



**Figure 6.2. *Included Instate* GHG emissions from 2010 to 2050 by sector for the 80% GHG reduction Step scenario (GHG-Step).**

The 2050 *Included Instate* emissions of the GHG-Line scenario are essentially identical to that of the GHG-Step scenario (99.3 MMTCO<sub>2</sub>e). The difference between the scenarios has to do with the trajectory of the carbon cap which declines linearly with time. Emissions follow the carbon cap until 2045 and then misses the cap in 2050 by 21 MMTCO<sub>2</sub>e like the GHG-Step scenario. The distribution of emissions into end-use sectors in 2050 is quite similar to GHG-Step.

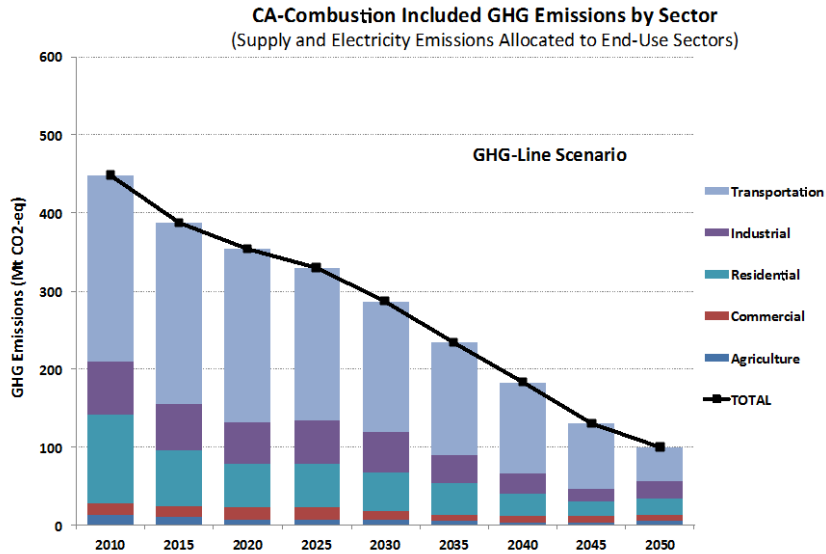


Figure 6.3. *Included Instate* GHG emissions from 2010 to 2050 by sector for the 80% GHG reduction Linear scenario (GHG-Line).

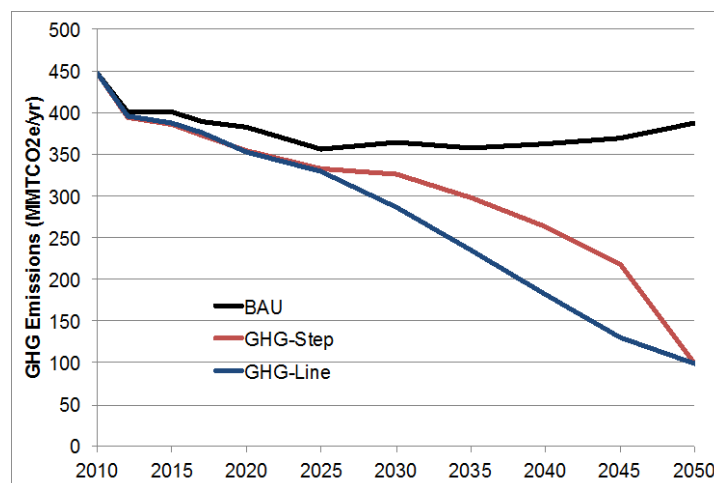


Figure 6.4. Comparison of *Included Instate* GHG emissions for the three primary CA-TIMES scenarios.

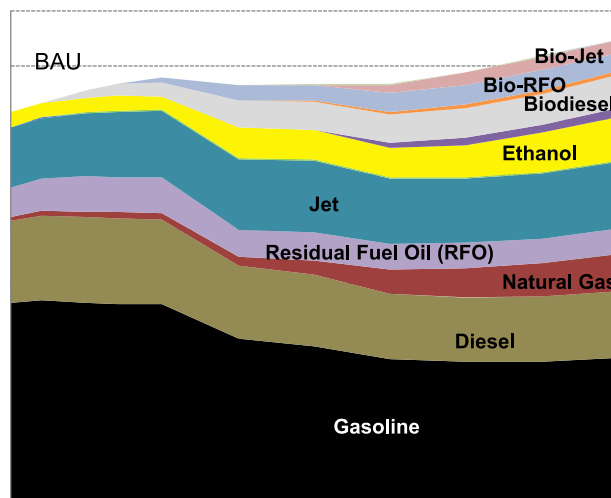
Figure 6.4 shows a comparison of the emissions trajectory of the three primary scenarios. While both GHG scenarios achieve the same emissions level in 2050, they do so with different paths and thus have different levels of cumulative emissions. Cumulative emissions for BAU are approximately 15.4 GTCO<sub>2</sub>e from 2010 to 2050 while the cumulative emissions of GHG-Step and GHG-Line are 12.5 and 11.1 GTCO<sub>2</sub>e respectively. There is a difference of approximately 1.4 GTCO<sub>2</sub>e between the two GHG scenarios in that 40-year period.

### 6.1.1 Transportation Sector

To better understand the broader scenario GHG emissions results, it is helpful to delve deeper into individual sectors to understand the shifts in technology choices and fuel and resource usage that drive these changes. The first sector of interest is the transportation sector, and end-use sector that accounts for the largest share of emissions in all of the scenarios (See Figures 6.1 through 6.3). As a result, the transportation sector is one of the most important sectors in CA-TIMES and is modeled with endogenous technology investment and fuel choice decisions.

Transportation demand (VMT, passenger miles and freight ton-miles) is expected to increase slightly (as discussed in Section 4.1) based upon projections from EMFAC2011 (CARB 2011) in BAU. However, these travel demand trends are offset by increasing efficiency in vehicles (especially light-duty) such that total fuel demand from the transport sector is only slightly higher in the Reference scenario in 2050. It is important to note that not all of the emissions from fuel used in the California transport sector are included in the emissions totals described above. The infrastructure and resources needed to provide fuel for interstate and international aviation and marine travel is included in CA-TIMES but emissions from their use are not included in the emissions cap. Figure 6.5 shows that total BAU transportation fuel demand is only 19% higher in 2050 relative to 2010 (4235 PJ vs. 3573 PJ or 32 billion gallons of gasoline equivalent (GGE) vs. 27 billion GGE). Starting in 2015 there is an increasing amount of biofuels used (including ethanol, biodiesel, bio-RFO and bio-jet). Total biofuel usage in 2050 is approximately 8x the biofuel usage in 2010, with significant growth in ethanol, biodiesel, bio-RFO and bio-jet. This shift in biofuels usage is driven in part by technology cost reductions in biofuel production and by increasing costs of oil imports. However, petroleum based transport fuels still make up the majority of transportation fuels (95% in 2010 and 66% in 2050).

There is a modest decline in the use of gasoline and ethanol between 2010 to 2050 (8%), even with increasing travel demand, due to improved efficiencies in light-duty cars and trucks. Light-duty on-road fuel economy is driven by the new federal fuel economy standards, which mandates a doubling of light-duty fuel economy to 2025. Test-cycle fuel economies for the light-duty vehicle fleet achieve approximately 55 mpg, which roughly translates to on-road values of 40 mpg.



**Figure 6.5. Transportation fuel consumption in Reference (BAU) scenario.**

Figures 6.6 and 6.7 show the transportation fuel demand in the GHG-Step and GHG-Line scenarios. In these scenarios, VMT is reduced by 24% in light-duty, and 10% in medium- and heavy-duty sectors relative to the BAU transport demands. Also important is the assumption that cars make up a greater share of light-duty vehicles in the GHG scenarios than in the BAU scenario (75% in GHG scenarios vs. 54% in BAU scenario). These two factors along with shifts in technology modeled within TIMES account for the reductions in fuel demand. Total transportation fuel demand in 2050 is ~2600 PJ or 19.7 billion GGE.

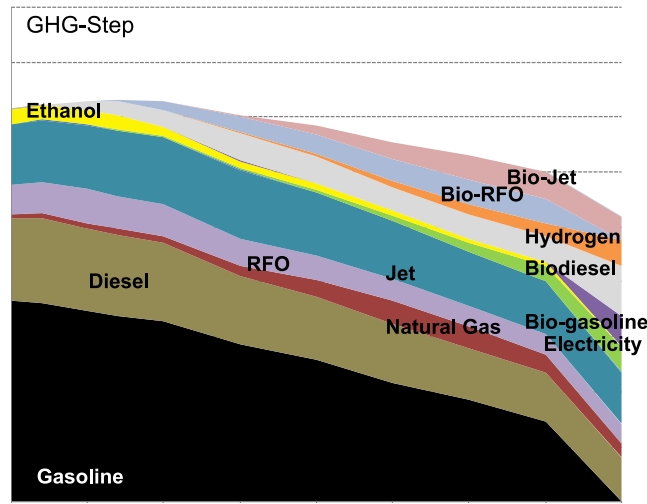


Figure 6.6. Transportation fuel consumption in 80% GHG step reduction scenario (GHG-Step)

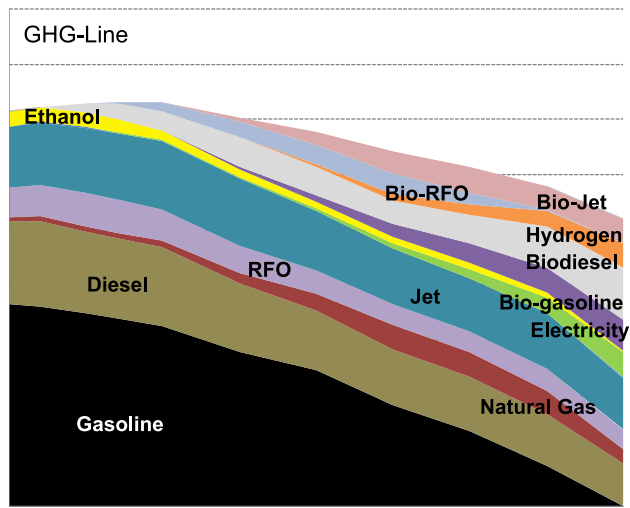


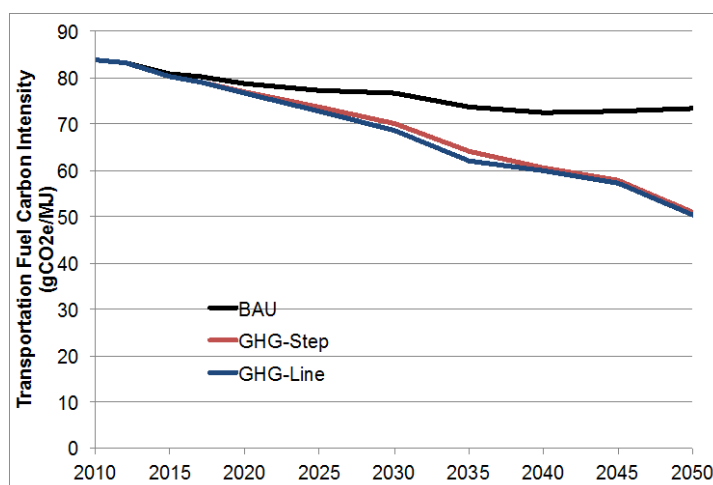
Figure 6.7. Transportation fuel consumption in 80% GHG linear reduction scenario (GHG-Line)

Both scenarios look remarkably similar in 2050 but differ somewhat in the timing of introduction and growth of alternative fuels. Petroleum based gasoline is entirely gone in 2050 as light-duty vehicles shift to electric drive vehicles. Diesel declines slightly but is still needed in heavy and medium duty trucks. Biofuels grow significantly to make up 37% of fuel use in 2050, while petroleum-based fuels account for approximately 41% of 2050 fuel use. The remainder comes from natural gas (5%), hydrogen (9%) and electricity (9%). The continued use of petroleum fuels are a primary reason that the two GHG scenarios do not meet the 80% reduction target, as petroleum emissions makes up the bulk of the transportation GHG contribution. This is primarily due to the lack of sufficient biofuels (and in particular diesel and jet fuel substitutes) to further displace these petroleum fuels. Also important is that because interstate/international aviation and marine are not included in the emissions cap, higher carbon petroleum

fuels are used in these excluded sectors while lower carbon biofuels are used in sectors included under the cap. The carbon intensity (CI) of fuels used in excluded transport categories in 2050 is 68 g/MJ in the GHG-Step and GHG-Line scenarios, whereas the CI of liquid fuels under the cap in these scenarios is 38 g/MJ.

The slight difference between the two GHG scenarios has to do with the timing of growth of alternative fuel. Given the more stringent cap in intermediate years for the GHG-Line scenario, alternative fuels are introduced earlier and necessarily grow faster than in the GHG-Step scenario. For example, gasoline use is reduced later in GHG-Step while bio-based gasoline is introduced earlier in GHG-Line.

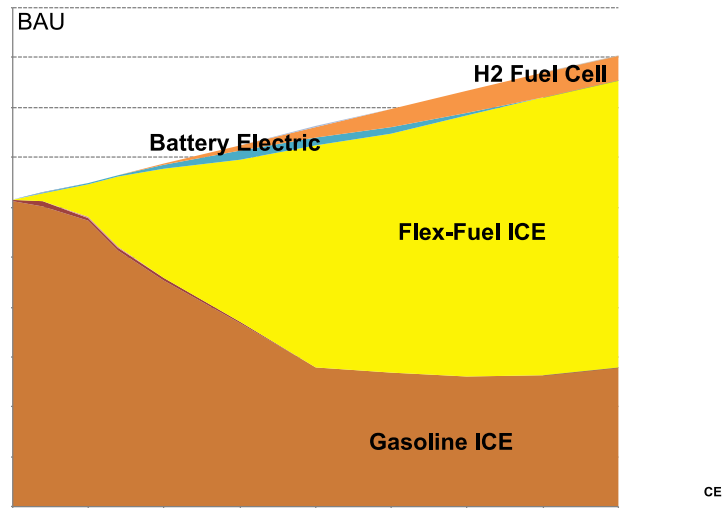
Overall the carbon intensities<sup>14</sup> of transportation fuels decline by 12% (to 73.5 g/MJ) in the Reference scenario vs. around 40% (to 50-51 g/MJ) in the GHG scenarios (see Figure 6.8). The slightly earlier timing of the shifts towards lower carbon intensity biofuels in the GHG-Line scenario relative to the GHG-Step scenario is also shown in the figure.



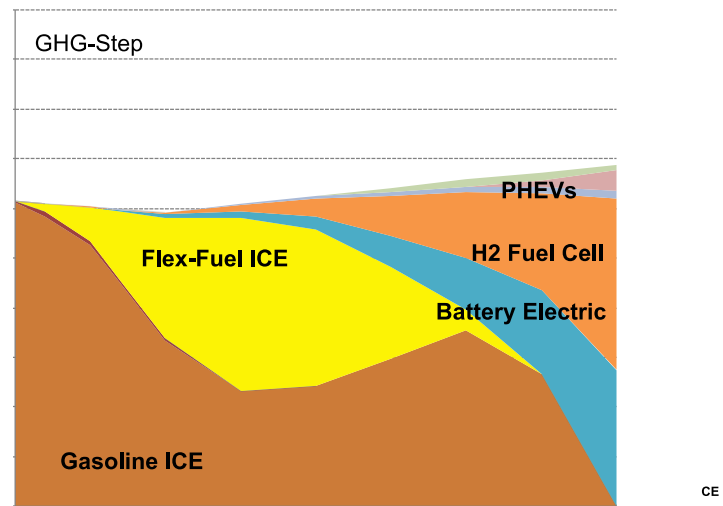
**Figure 6.8. Comparison of the carbon intensity of transportation fuels in the three primary CA-TIMES scenarios.**

Figure 6.9 shows the light-duty vehicle fleet mix contributions to VMT in the Reference scenario. The results show that light-duty vehicles continue to rely primarily on internal combustion engines and liquid gasoline-like fuels. Conventional gasoline vehicles decline significantly. The bulk of vehicles consists of Flex Fuel Vehicles (FFVs) in 2030 and beyond that are essentially conventional internal combustion engine vehicles with a slight modification to allow them to use up to 85% ethanol. Figure 6.5 shows that ethanol consumption is modest (about 33% of gasoline on an energy (HHV) basis, which is equivalent to E33 if they were exclusively blended), but FFVs are quite low cost and allow the vehicles to run on any blend of gasoline and ethanol, overcoming any “blend wall” issues that limit ethanol in conventional gasoline vehicles. Battery electric vehicles (BEVs) represent a small proportion of vehicles in 2020 to 2040 (about 1-3% of vehicles), while fuel cell vehicles (FCVs) grow to about 5% of vehicles in 2050. These vehicles are chosen primarily because they satisfy the ZEV mandate. It is important to reiterate that the current iteration of the CA-TIMES model does not represent consumer heterogeneity in LDV purchases and as such, because BEVs, PHEVs and FCVs are not the least cost vehicles (accounting for vehicle purchase, fuel costs and including hurdle rates), they are not chosen except when required to meet a constraint (in this case, the ZEV mandate).

<sup>14</sup> Note that these carbon intensity values are based upon the higher heating value of the fuel.



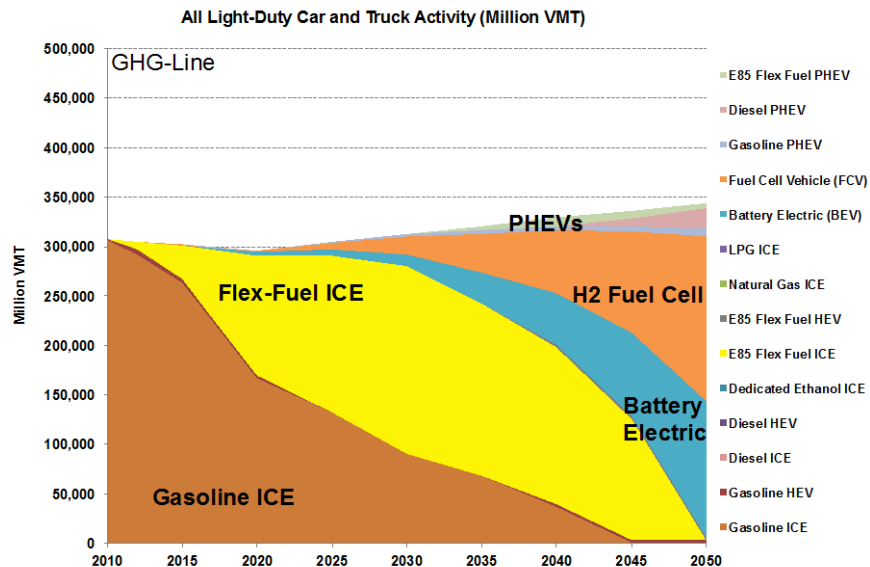
**Figure 6.9. Light-duty vehicle VMT by vehicle type in Reference (BAU) scenario.**



**Figure 6.10. Light-duty vehicle VMT by vehicle type in 80% GHG step reduction scenario (GHG-Step).**

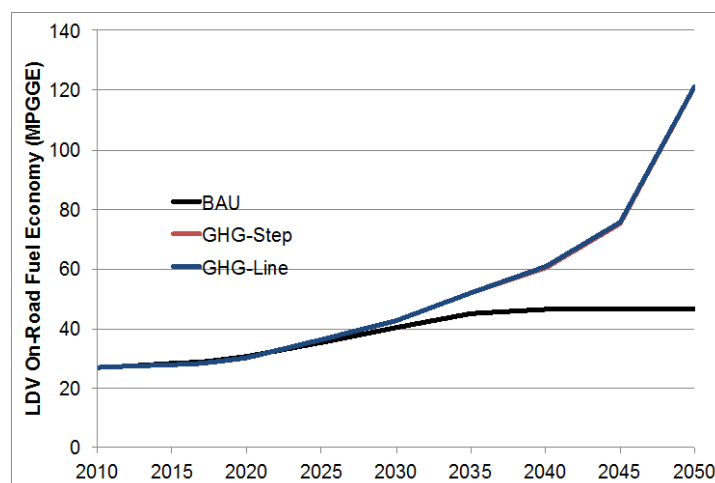
Figure 6.10 shows the mix of light duty vehicles for the GHG-Step scenario. We see a dramatic shift in the vehicle mix starting in 2030 when there is significant growth in battery electric vehicles (BEVs) and hydrogen fuel cell vehicles (FCVs). Also shown is some use of plug in hybrid electric vehicles. One of the model assumptions is that all plug-in vehicles can have a maximum share of 50% and that BEVs, specifically, can only have a maximum share of 40%, due to limitations on the availability of home-based recharging infrastructure. Plug-in vehicles achieve these maximum shares in 2050 (BEVs 40% and PHEVs 10%). The contribution of FCVs starts slowly due to the challenges of hydrogen refueling stations and vehicle deployment and is represented in the model as high early costs. However, after 2030, FCVs grow rapidly to 50% of the fleet due to competitive costs (approximately \$5000 more than gasoline cars/trucks), high efficiency and low carbon hydrogen (made primarily from natural gas with 33%

renewable hydrogen from biomass and electrolysis). Other low-carbon options for hydrogen production like fossil with CCS is not an option and electrolysis is limited due to availability of additional renewable electricity. Pure internal combustion engine vehicles (not PHEVs) are eliminated from the vehicle fleet in 2050.



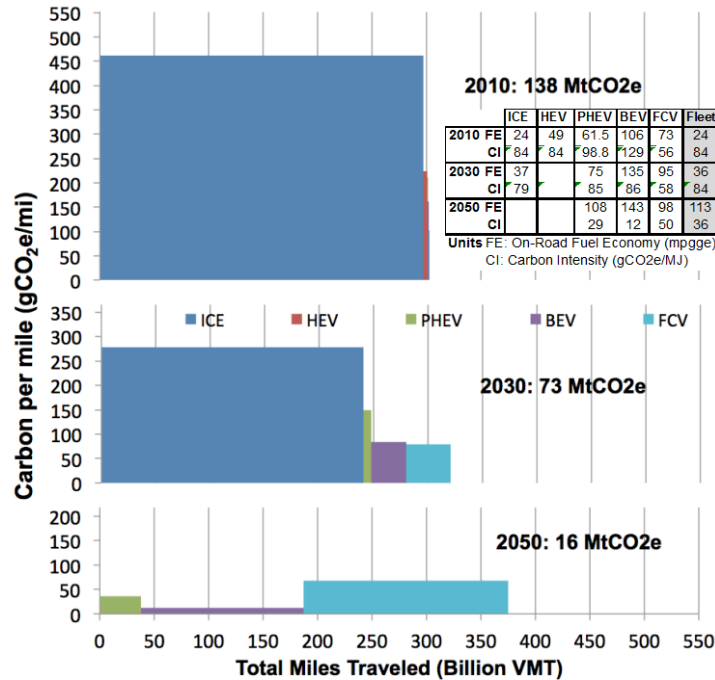
**Figure 6.11. Light-duty vehicle VMT by vehicle type in 80% GHG Linear Reduction Scenario (GHG-Line).**

In the linear GHG scenario, the 2050 fleet share for PHEVs and BEVs is essentially the same as in the GHG-Step scenario (Figure 6.11), with the exception of a small share of HEVs (1.6%). 2050 fleet share is 50% PEVs, 48.4% FCVs and 1.6% HEVs. The most noticeable difference is the major reduction in the amount of FFVs in the GHG-Line scenario relative to GHG-Step between 2020 and 2040. The FFVs are used in the GHG-Line scenario to meet the interim GHG targets while the ZEVs are being slowly ramped up.



**Figure 6.12. Comparison of light-duty vehicle fleet fuel economy (on-road) for the three primary scenarios.**

Figure 6.12 shows how the fleet fuel economy differs between the three scenarios. The Reference scenario achieves 40 mpgge on-road for LDVs which tracks the updated CAFE standards to 2035. LDVs in the GHG-Step and GHG-Line scenarios achieve over 110 mpgge in 2050 and the trajectory of fleet-wide fuel economy is the same.



**Figure 6.13. Comparison of the carbon per mile and miles traveled for different vehicle types and total emissions from LDVs in 2010, 2030 and 2050 for the GHG-Step scenario.**

Figure 6.13 shows the carbon per mile for different vehicle types in different years for the GHG-Step scenario. The carbon intensity of fuel (gCO<sub>2</sub>/MJ) is multiplied by the fuel consumption (MJ/mile) to obtain the carbon per mile (gCO<sub>2</sub>e/mile) on the y-axis. The number of miles that vehicle travels is on the x-axis and the product of these two factors (i.e., area of a given colored block) is the total GHG emissions from a given vehicle type. The sum of areas of all blocks gives the total GHG emissions from LDVs. Light-duty is pretty much decarbonized in 2050 only emitting only 15 MMTCO<sub>2</sub>e (89% reduction from 2010 emissions).

In other transportation sub-sectors, the GHG scenarios show significant increases in vehicle efficiency relative to the Reference scenario (Figure 6.14). Heavy-duty vehicles can achieve approximately 10 mpgge in the GHG scenarios in 2050 vs. around 5.5 mpgge in 2010. The Reference scenario shows only a modest increase in heavy-duty truck efficiency by 2050 (to 7 mpgge). The significant increase in heavy-duty efficiency in the GHG scenarios is due entirely to adoption of more costly and high-efficiency diesel trucks.

In the medium duty truck subsector, there is greater potential for efficiency improvements with the potential adoption of hydrogen and plug-in hybrid vehicles. Efficiency improves from 9 mpgge in 2010 to approximately 17.5 mpgge in 2050 in the GHG scenarios (vs. 11 mpgge in the Reference scenario). CNG makes up a moderate fraction (29%) of the medium duty vehicle fleet in 2050 and PHEVs (63%) make up the majority.



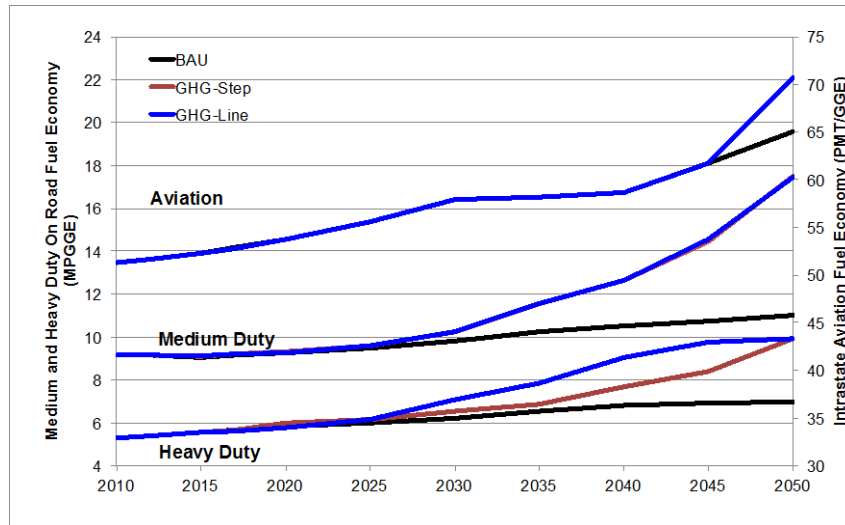


Figure 6.14. Comparison of the fuel economy in heavy-duty and medium-duty trucks and intrastate passenger aircraft for three primary scenarios.

In the aviation subsector, the difference in efficiency improvement between the Reference and GHG scenarios is not that great. For example, intrastate passenger aircraft has a fuel economy of 51 passenger miles/GGE in 2010. There is a steady increase in aircraft efficiency such that by 2050, the fuel economy is 65 pass-mi/GGE for the Reference scenario and 71 pass-mi/gge for the two GHG scenarios.

### 6.1.2 Commercial, Residential, Industrial and Agricultural Sectors

This section details the other end-use sectors (commercial, residential, industrial, and agricultural), which contribute about 47% of emissions in 2010 and about 55% in 2050 in the GHG scenarios.

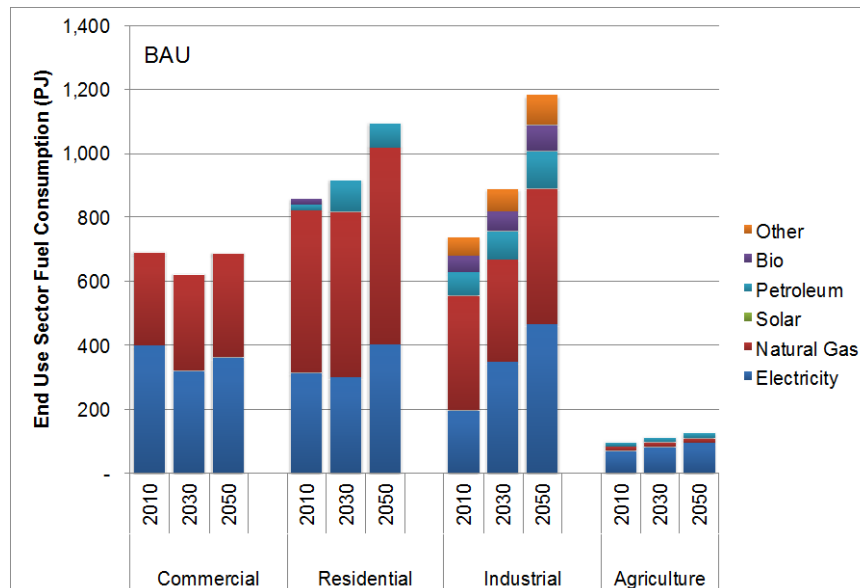
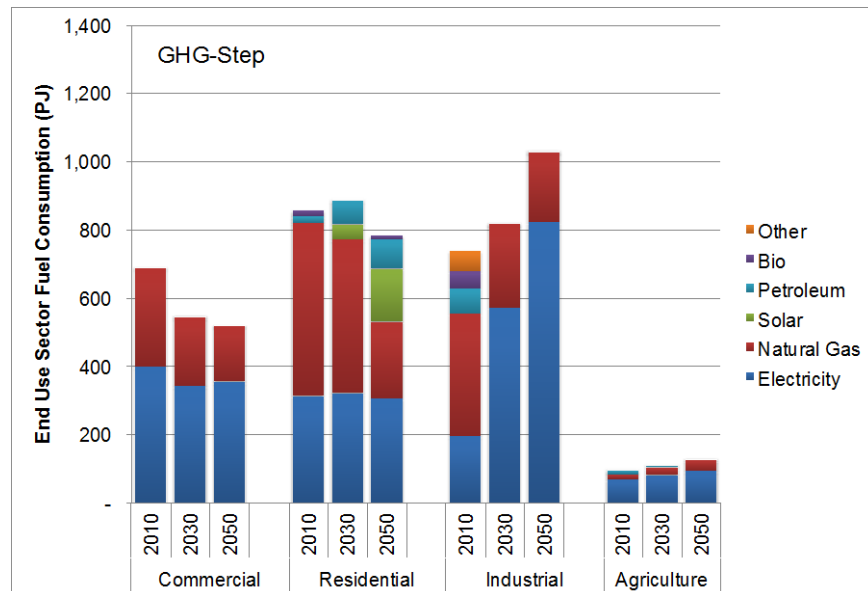


Figure 6.15. Final energy (fuel) demands for commercial, residential, industrial and agricultural sectors in the Reference scenarios.

Figure 6.15 shows the final energy demands for these end-use sectors in 2010, 2030 and 2050. The industrial and agricultural fuel demands are input assumptions to the model (as described in Sections 4.4

and 4.5) while the fuel demands for the commercial and residential sectors are endogenously determined within the model via choices about different technologies. In the GHG scenarios, the industrial and agricultural sectors are assumed to be more efficient and also shift final energy usage to a greater proportion of electricity use (see Sections 4.4 and 4.5).



**Figure 6.16. Final energy (fuel) demands for commercial, residential, industrial and agricultural sectors in the GHG-Step scenario.**

In Figure 6.16, the energy use in the commercial and residential sectors for the GHG-Step scenario is quite different than the BAU scenario. The mix of fuels used is shifted (the share of electricity rises) and the total energy demand is reduced. Given the rise in commercial floorspace and residential household population increase, electrification and efficiency are used to counteract the increase in total energy services in these sectors. From 2010 to 2050, commercial final energy use declines by 25% while the share of electricity rises from 58% to 69%. Residential final energy use declines by 9% and electricity's share of final energy rises from 36% to 39%. Solar (for water heating) is also used significantly in 2050 (20% of residential energy use).

Figure 6.17 shows the energy usage for the commercial, residential, industrial and agricultural sectors in the GHG-Line scenario. The industrial and agricultural sectors are identical to the GHG-Step scenario as are the 2050 energy use and final energy split for the commercial and residential sectors. However, because the carbon caps in the intermediate years are different, the energy use, final energy mix and system efficiency are different. In 2030, GHG-Step has higher final energy use in the commercial and residential sectors than GHG-Line (by 2-6%).

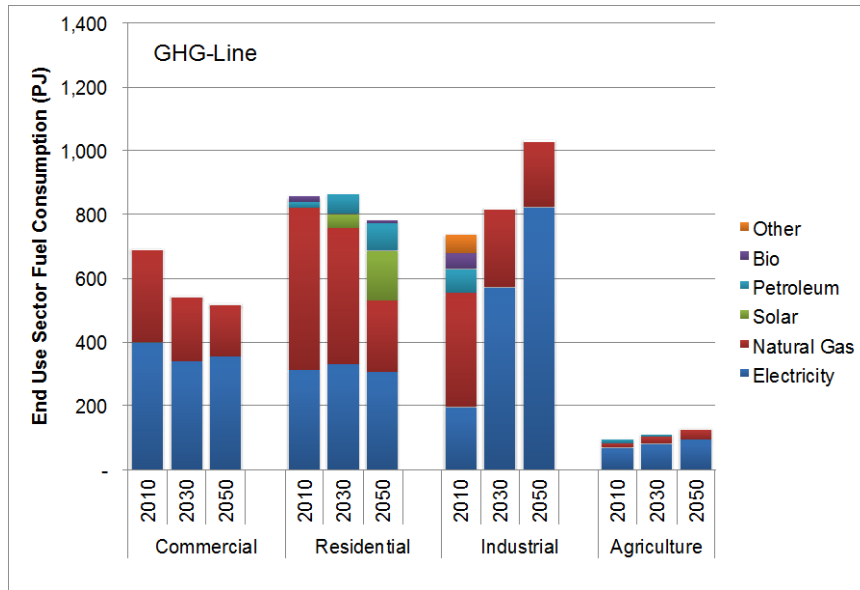


Figure 6.17. Final energy (fuel) demands for commercial, residential, industrial and agricultural sectors in the GHG-Line scenario.

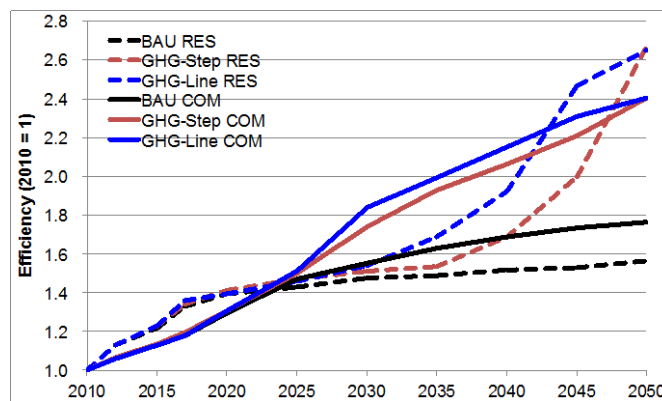


Figure 6.18. Indexed weighted efficiency in the residential and commercial sectors in the three primary scenario.

Figure 6.18 shows the efficiency improvement of the residential and commercial sectors in the three primary scenarios. The Reference scenario shows substantial improvements from 2010 to 2050 (a factor of 1.8 in the commercial sector and 1.6 in the residential sector). The GHG scenarios show even greater efficiency improvements by 2050 (2.7x in the residential sector and 2.4 in the commercial sector). The biggest contributors to the sectoral efficiency improvements are seen in commercial and residential heating (i.e., heat pumps) and lighting (i.e., LED).

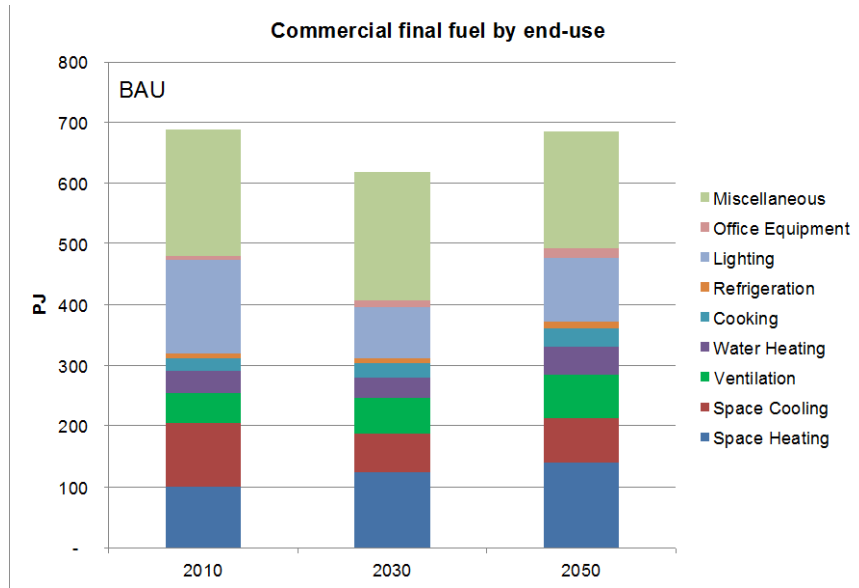


Figure 6.19. Commercial sector final energy use by energy services in the Reference (BAU) scenario.

Figures 6.19 and 6.20 show the final energy usage by energy service within the commercial and residential sectors for the Reference scenario. The biggest demands for energy in the commercial sector are space heating, space cooling, lighting and miscellaneous. Service demand is growing for these energy services because of growth in commercial floorspace (67% growth between 2010 and 2050). No improvements/reductions in miscellaneous energy usage are assumed. The largest service demands for the residential sector are space heating and water heating.

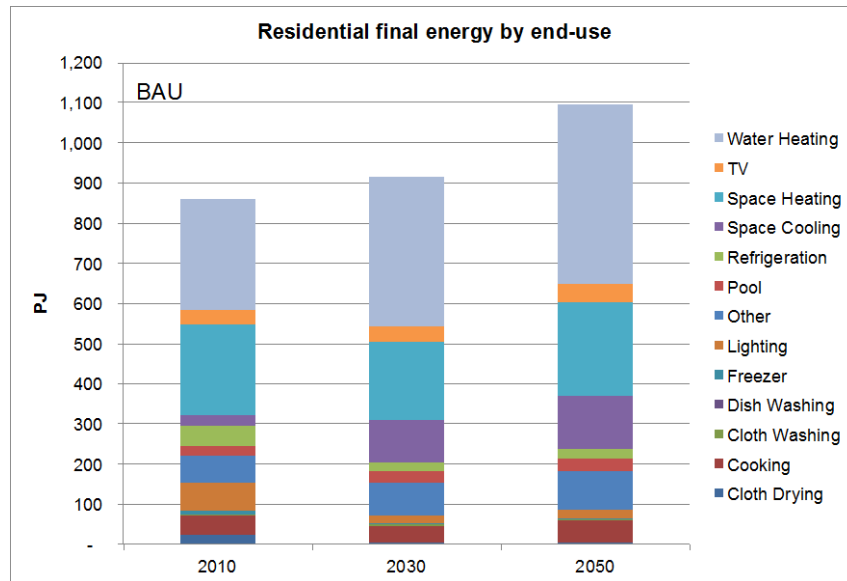
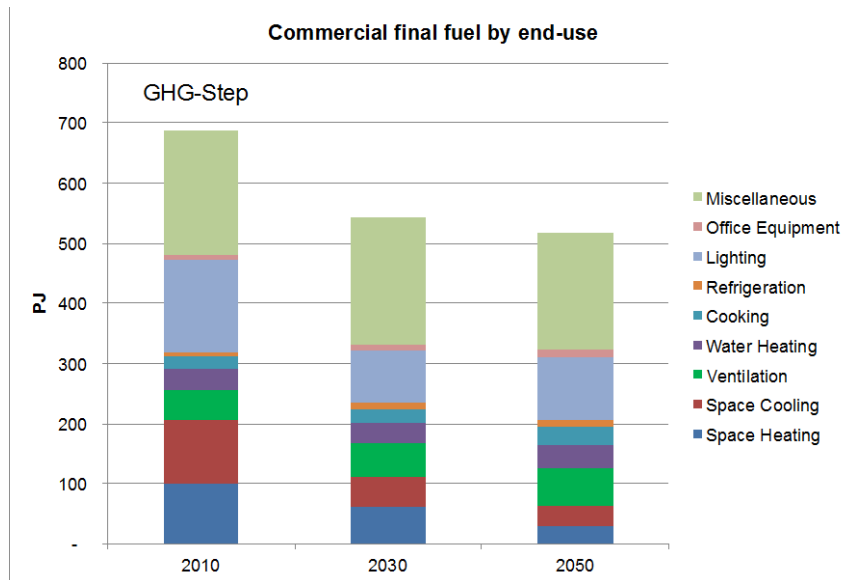


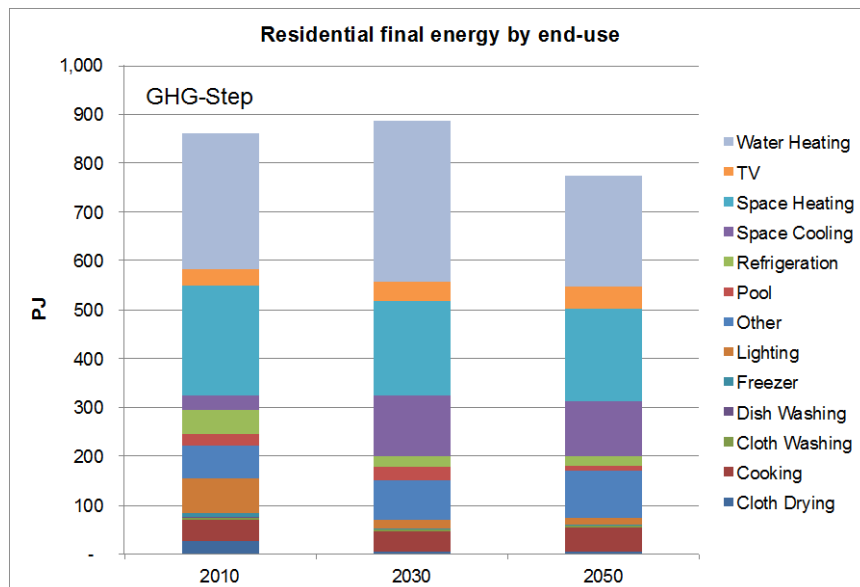
Figure 6.20. Residential sector final energy use by energy services in the Reference (BAU) scenario.



**Figure 6.21. Commercial sector final energy use by energy services in the GHG-Step scenario.**

Figures 6.21 and 6.22 show the commercial and residential final energy use broken out by energy service for the GHG-Step scenario. There are large reductions in energy use in the commercial sector in space heating, space cooling, and lighting energy. Again, miscellaneous is a large portion of the final energy use in the commercial sector because technology/efficiency changes are not modeled for this service.

The residential sector energy services that show significant energy use reductions are water heating, lighting, space heating and clothes washing. Many other energy services do not show any significant reductions in energy use, such as TV, cooking and other, while space cooling energy demand increases significantly. The results for GHG-Line are identical to those in the GHG-Step scenario in 2050 and very similar in 2030.



**Figure 6.22. Residential sector final energy use by energy services in the GHG-Step scenario.**

### 6.1.3 Electric Sector

The last two sections described the changes in final energy use and technology adoption within the end-use sectors. These next two sections describe the energy supply sectors that provide electricity and fuels to the end-use sectors.

Electricity is a critical component of the energy supply mix and major changes to generation and demand are essential in meeting the 80in50 targets. Decarbonizing the electric sector is critical in reducing the state’s emissions, because one of the key strategies for reducing emissions is shifting fossil fuel usage from petroleum and natural gas to electricity in end use sectors. As electricity demand rises as a result of this electrification, the sector must also re-invest in low carbon technologies. Cost reductions in renewables and other low carbon sources make it feasible to achieve low carbon intensity at reasonable costs.

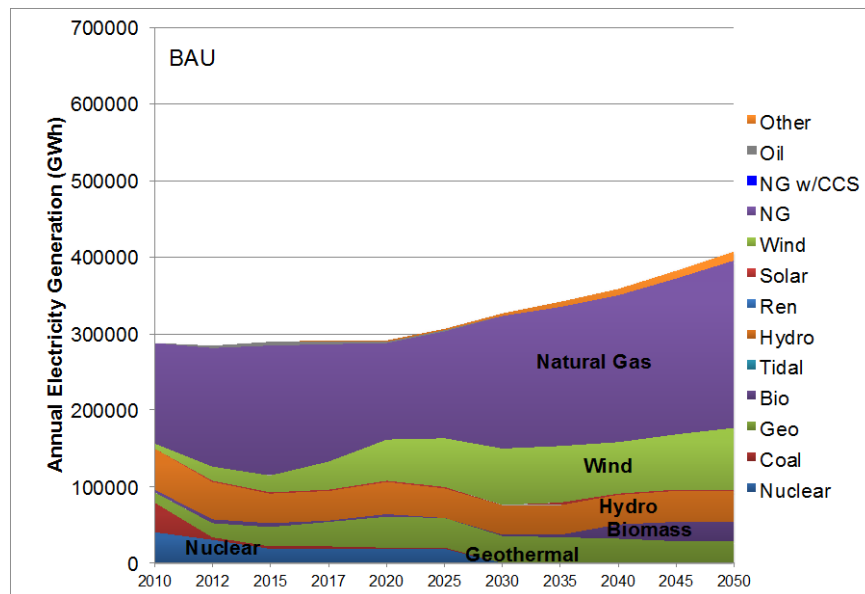


Figure 6.23. Electricity generation by resource type in the Reference (BAU) scenario.

Figure 6.23 shows the annual electricity generation mix from 2010 to 2050 in the Reference scenario. Overall electricity usage climbs from 288 TWh to 407 TWh in 2050, a 41% increase. With respect to the generation mix, there is a phase out of nuclear due to the closing of San Onofre Nuclear Generating Station (SONGS) in 2013 and then the state’s remaining nuclear plant (Diablo Canyon) in 2025. As modeled, all new generation is assumed to be purpose-built for use by California, so the investment, O&M, and other variable costs associated with electricity generation are allocated entirely to the California energy system. Coal imports are phased out and growth in electricity generation comes primarily from renewables. The rapid increase in wind power is due to significant reductions in the cost of wind turbines with much of the generation coming from out of state resources (and associated transmission lines). Wind grows to 80 TWh/yr in 2050, while solar, geothermal, and biomass contribute 2, 28 and 26 TWh/yr respectively. Overall, renewables make up 33% of total generation, which is consistent with the state’s RPS, though with large hydro, the renewable percentage is 43%. The largest contributor to the state’s electricity mix continues to be natural gas, which increases generation from 176 TWh in 2010 to 232 TWh in 2050, but remains a bit more than half of all generation throughout the modeling period. There is a small contribution of “Other” generation, which comes from by-product electricity generation in bio-refineries, i.e., cellulosic ethanol plants, pyrolysis and Synfuel (Fischer Tropsch) plants.

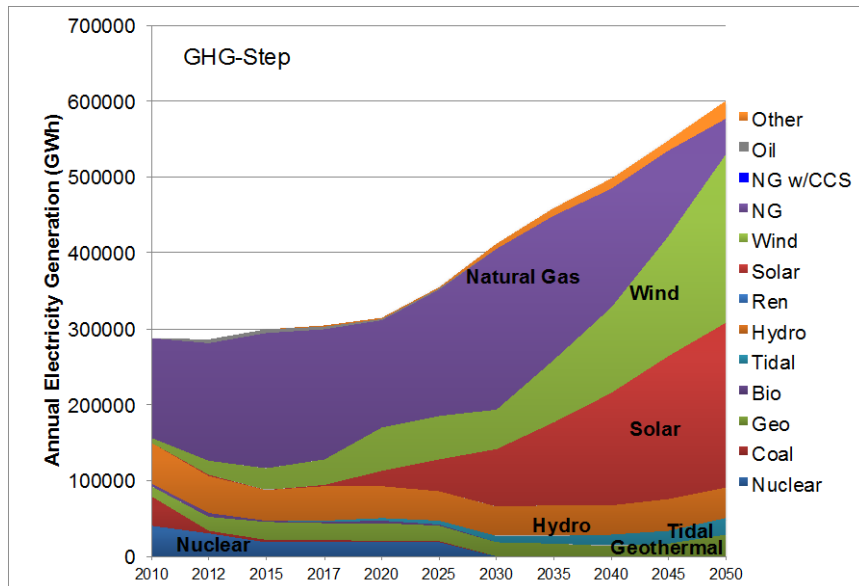


Figure 6.24. Electricity generation by resource type in the 80% GHG Step Reduction Scenario (GHG-Step).

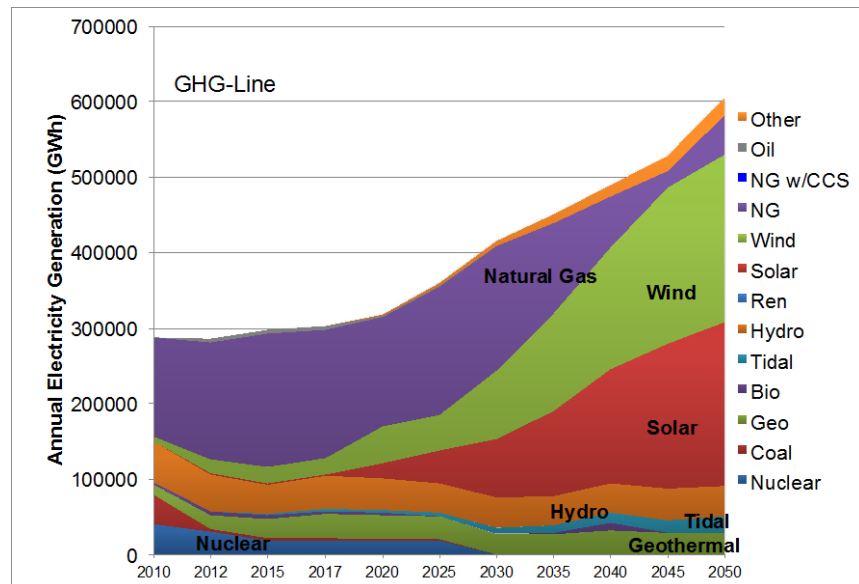
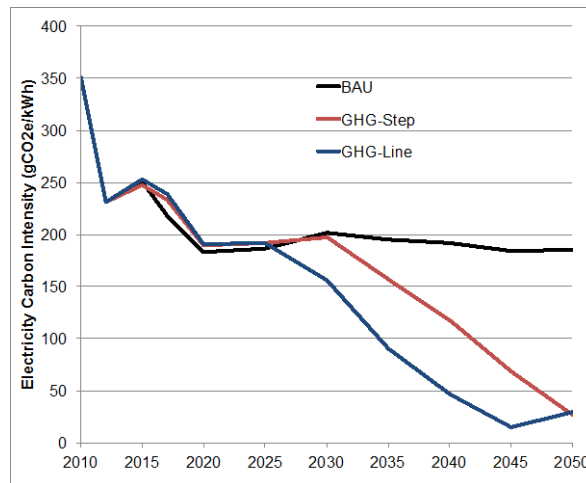


Figure 6.25. Electricity generation by resource type in the 80% GHG Linear Reduction Scenario (GHG-Line).

Figure 6.24 and Figure 6.25 show the generation mix for the GHG-Step and GHG-Line scenarios. One big difference between these scenarios and the Reference scenario is the large increase in electricity demand that is needed by 2050. Instead of 407 TWh in the Reference scenario, electricity generation in these GHG scenarios is approximately 600 TWh in 2050, approximately 50% more. The only viable option to decarbonize the electricity supply in these scenarios is renewables (since nuclear and carbon capture technologies are not available in these scenarios). Geothermal and tidal generation expand as much as the economically feasible resource allows in 2050 to 28 TWh and 22 TWh respectively. Solar and wind power make up the bulk of the generation in 2050, with utility scale solar thermal, solar PV and wind contributing 107 TWh, 110 TWh and 221 TWh, respectively. The installed capacity for solar thermal, solar PV and wind generation are 45 GW, 58 GW and 74 GW, respectively. Notable is the lack of biomass-based electricity generation in the GHG scenarios since these energy resources are used to make biofuels (which is discussed in subsequent sections). Renewable contributions to electricity generation are 81% when excluding hydropower (i.e., only RPS eligible generation) and 88% when

including hydropower. Another 4% comes from excess electricity generation from bio-refineries. The remaining 8% comes from natural gas (primarily combined cycle, with some contribution from combustion turbines). The 2050 generation mix for GHG-Line is very similar to GHG-Step.

The biggest difference between the two GHG scenarios again has to do with the timing of the ramp up of the low-carbon renewable generation resources. In 2025-2030, when the GHG-Line carbon cap starts to decline relative to the GHG-Step cap, renewable (solar and wind) generation is higher, while natural gas generation is lower.



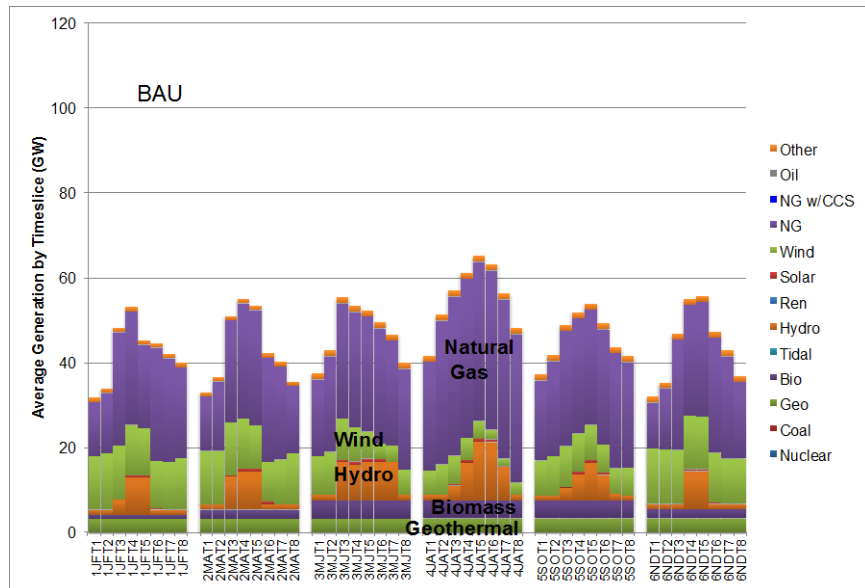
**Figure 6.26. Carbon intensity of electricity generation in three primary CA-TIMES scenarios.**

Figure 6.26 shows the carbon intensity of electricity (gCO<sub>2</sub>/kWh) for each of the three primary CA-TIMES scenarios. The carbon intensity of the Reference scenario declines to around 200 g/kWh in 2020 and more or less constant to 2050 (184 g/kWh), while the two GHG scenarios eventually decline to below 30 g/kWh. The remaining emissions from electricity generation are due to the continued use of natural gas generation, which is needed for load balancing and makes up 8% of generation in 2050.

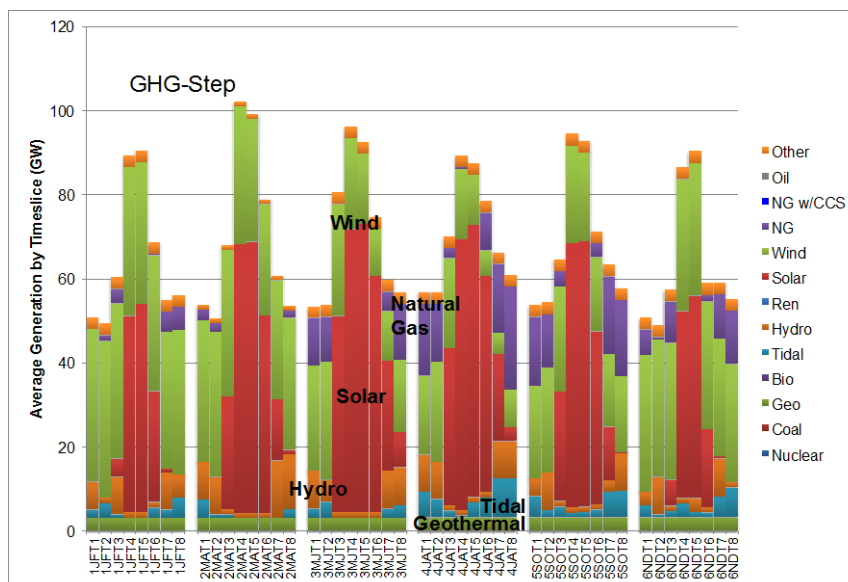
As noted previously, the CA-TIMES optimization must ensure that supply and demand for electricity are balanced in each of the forty-eight sub-annual timesteps. Thus, the timing of generation from different resources is part of the optimization process for investing in electric power plants of different types (along with policy constraints like RPS). Matching electricity supply and demand is a critical aspect of operating the electricity grid. When introducing significant levels of intermittent renewables, such as wind and solar, it is important to ensure that there is sufficient flexibility in the system to handle the variability<sup>15</sup>. Figure 6.27 shows the sources of electricity generation by timeslice. 2050 electricity demand in the BAU scenario is highest in the summer months (July-August), yet that is when wind power generates the least amount of electricity, so back up natural gas plants are especially active during these months.

<sup>15</sup> CA-TIMES currently does not model future investments in electricity storage beyond existing pumped hydro systems.





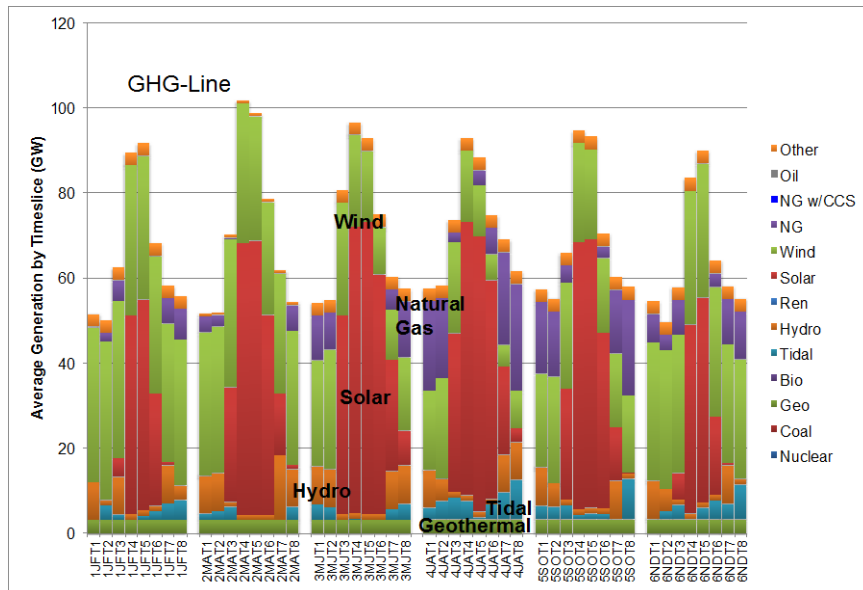
**Figure 6.27. Electricity generation by resource type and timeslice in the Reference (BAU) scenario in 2050. See section 3.5.5 for more info on timeslices. JF: January/February; MA: March/April; MJ: May/June; JA: July/August; SO: September/October; ND: November/December. The daily time period is grouped into three-hour time slices. Thus the daily time period 1 (T1) corresponds to 12 am-3 am, and so on.**



**Figure 6.28. Electricity generation by resource type and timeslice for 2050 in the 80% GHG-Step Reduction Scenario (GHG-Step).**

Figure 6.28 shows the same timeslice generation for 2050 for the GHG-Step scenario. The penetration of wind and solar is such that on average, intermittent generation makes up more than 66% of timeslice generation, and in many timeslices it can make up more than 90% of total generation. In these GHG scenarios, only hydropower and natural gas generation are available for dispatchable, responsive generation, while the remainder of generation assets are either intermittent renewables or must-run baseload power. This can present challenges to the operation of the grid in terms of balancing supply and demand, frequency regulation, having sufficient spinning reserves and ensuring system reliability. One interesting point to note is that the summer generation peak is non-existent and we actually see peak demand occurring in the spring (March & April) when both wind and solar output is at its highest. The

change in seasonality of demands is in part a result of a shift towards space heating with electric appliances (e.g., heat pumps). Also, flexible PEV charging, which tries to minimize the use of marginal natural gas generation, takes advantage of the high renewable output in the spring peak generation hours. Figure 6.29 shows the same graph but for the GHG-Line scenario. These two GHG scenarios are quite similar in terms of the timeslice generation in 2050.



**Figure 6.29. Electricity generation by resource type and timeslice in the 80% GHG Linear Reduction Scenario (GHG-Line).**

### 6.1.4 Fuels Supply Sector

Section 6.1.1 discussed the transportation fuel mix in the three primary CA-TIMES scenarios and Section 6.1.2 showed the fuel use for the different end-use sectors (residential, commercial, industrial and agricultural). This section will further discuss the energy supplies used throughout the energy system and the processes used to deliver the final fuels.

Biomass and biofuels are major areas of interest when discussing reducing greenhouse gas emissions with low carbon fuels. Figure 6.30 shows the significant growth in biofuels production in the BAU scenario. Even though there isn't a carbon cap, the rising price of oil (up to \$180/bbl in 2050) prompts a shift towards substitute liquid fuels. Biofuel consumption is 1080 PJ or 8.2 billion gallons of gasoline equivalent (billion GGE). However, not all of this fuel is low carbon (15% is corn-based ethanol). Biomass utilization is approximately 1632 PJ in 2050.

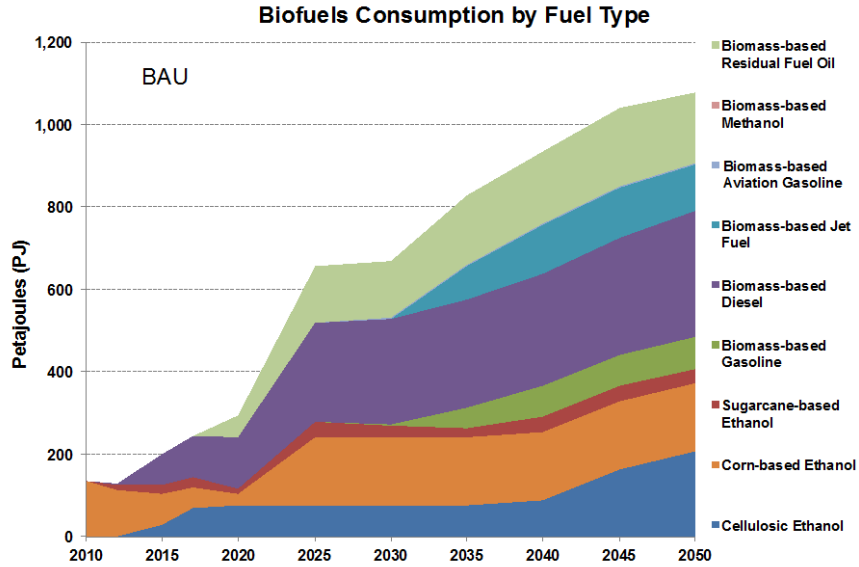


Figure 6.30. Annual biofuel production by category for the Reference (BAU) scenario.

Figures 6.31 and 6.32 show the biofuels production in the GHG scenarios. Interestingly, these two scenarios have slightly lower biofuel production than the BAU scenario (in 2050, the GHG scenarios have approximately 963 PJ of biofuels (~7.3 billion GGE) compared with 1080 PJ for BAU). The mix of biofuels is somewhat different between the BAU and GHG scenarios. The BAU scenario has a significant amount of gasoline substitutes (ethanol and bio-gasoline), comprising 43% of all biofuels production in 2050. In the GHG scenario, gasoline substitutes account for less than 30% of biofuels production. The remainder of biofuels production is used as diesel and jet fuel substitutes. This is due to the extent of electrification that is found in the light-duty sector. The primary users of gasoline (and ethanol) are medium-duty trucking and aviation, which cannot be electrified as easily.

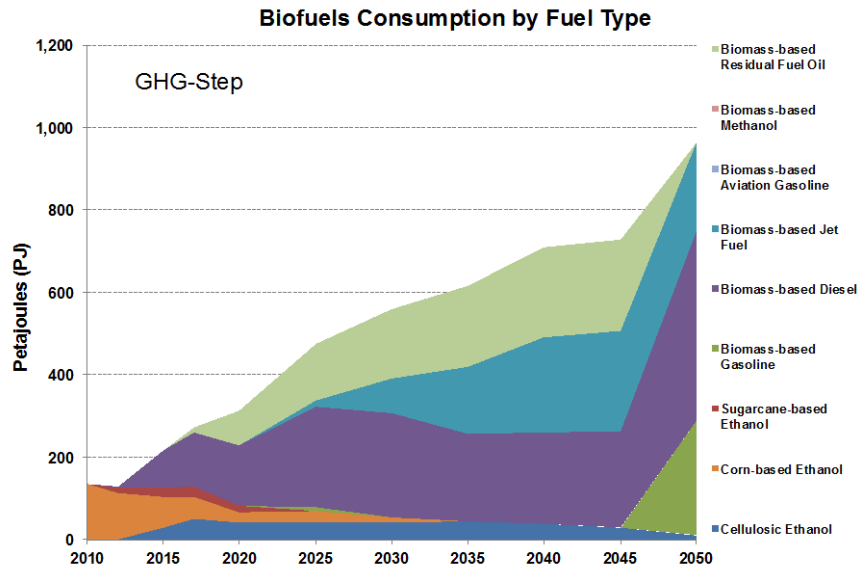


Figure 6.31. Annual biofuel production by category for the 80% GHG-Step Reduction Scenario (GHG-Step).

And again, these two scenarios look identical in 2050 but differ with respect to the trajectory of fuels production in the intermediate years. In the GHG-Step scenario, biofuel production ramps up quite significantly in 2045 to meet the 2050 goal, though this rate of production increase may be unrealistic.

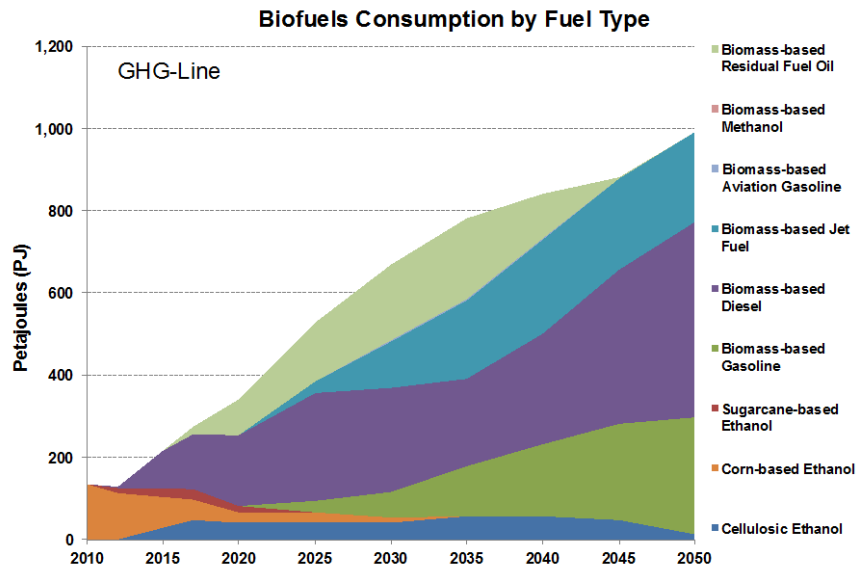


Figure 6.32. Annual biofuel production by category for the 80% GHG-Step Reduction Scenario (GHG-Line).

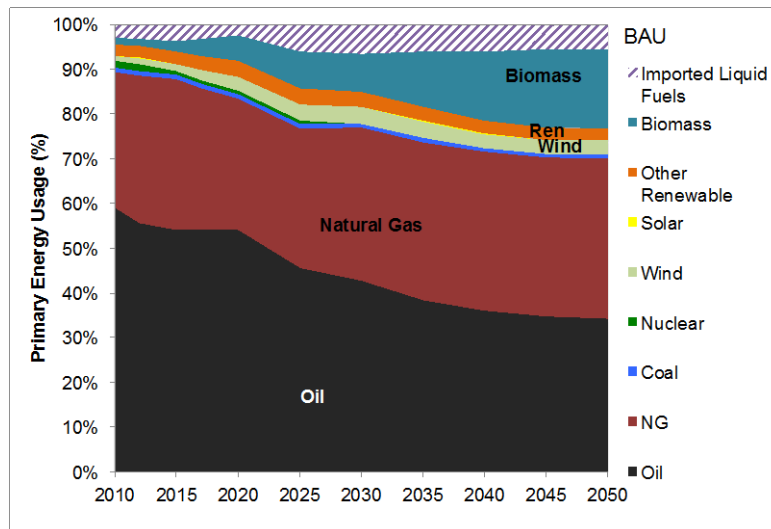
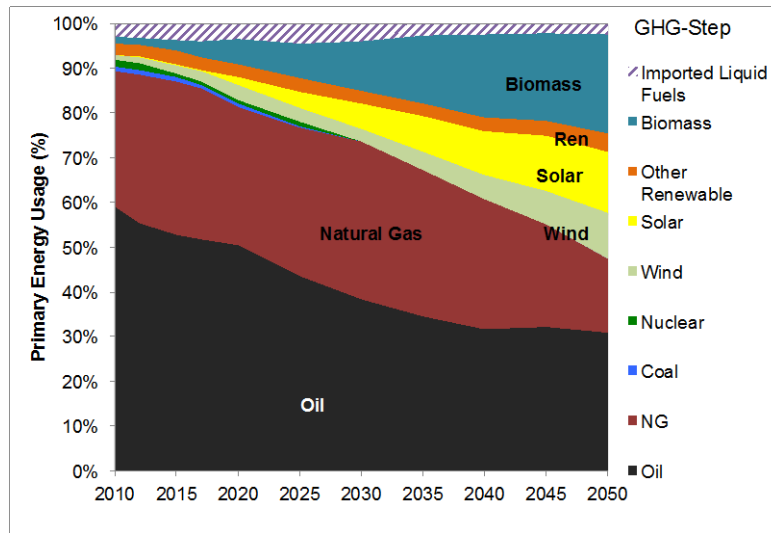


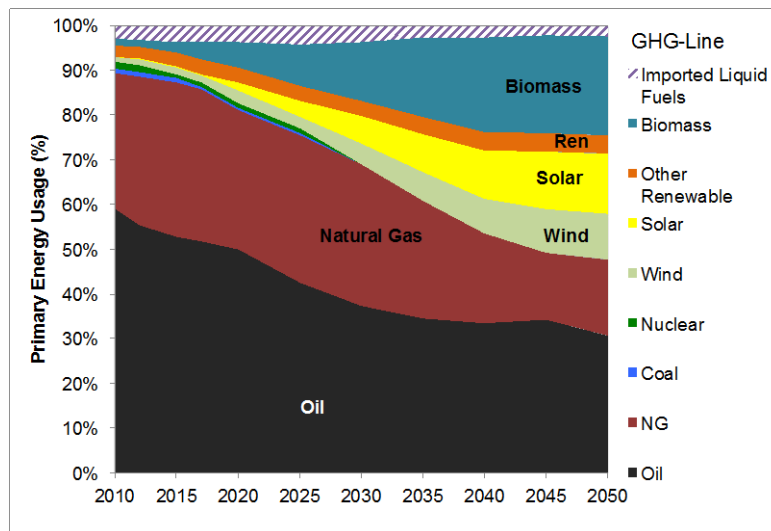
Figure 6.33. Annual share of primary energy resources for the Reference (BAU) scenario.

Figure 6.33 shows the annual share of different primary energy resources used in the Reference scenario. Even without a cap on carbon, we see a drop in the reliance on fossil fuel resources from around 92% in 2010 to approximately 74% in 2050. Oil represents the resource that loses the most share (from 60% to 36%) from 2010 to 2050, corresponding to the rising price of oil and the availability and cost reductions for many efficient transportation technologies. Biomass makes up for the reduction in petroleum usage by

growing from approximately 2% of primary energy usage to around 19%. Wind is another growing resource (though small relative to the growth in biomass)<sup>16</sup>.



**Figure 6.34. Annual share of primary energy resources for the 80% step GHG emissions reduction (GHG-Step) scenario.**



**Figure 6.35. Annual share of primary energy resources for the 80% linear GHG emissions reduction (GHG-Line) scenario.**

Figures 6.34 and 6.35 show the annual share of primary energy resources for the two GHG scenarios (GHG-Step and GHG-Line). The share of fossil fuels declines to around 49% (oil 32% and natural gas 17%), while renewables (and biomass) grow to make up around 50% of primary energy supply. The shift from fossil fuels to renewables occurs earlier in the GHG-Line scenario than the GHG-Step scenario because of the more restrictive carbon cap between 2020 and 2045.

<sup>16</sup> Resources for wind, solar and other renewables that are used primarily for electricity production are calculated based upon electricity production rather than chemical, mechanical or electro-magnetic energy that are inputs to the renewable generator. For example, the electrical output of a solar panel is counted as the primary energy rather than the solar insolation that falls on the panel.

### 6.1.5 Energy System Costs

An understanding of the costs associated with GHG reductions is important. Table 6.1 shows the sum of undiscounted and discounted<sup>17</sup> annual energy system costs that are accounted for within the CA-TIMES model and the cumulative in-state energy system emissions from 2010 to 2050. A second BAU scenario is added (BAU-LoVMT), which matches the lowered VMT that is assumed in the GHG-Step and GHG-Line scenarios. This makes for a more convenient comparison with the GHG scenarios since they will have the same level of energy service demands. The lower VMT assumptions in the BAU-LoVMT and GHG scenarios lead to a reduction in the vehicle stock needed to provide VMT and thus lower system costs. The undiscounted total energy system costs from 2010 to 2050 are on the order of 7.9 to 9.2 trillion dollars (or 3.2 to 3.6 trillion dollars in net present value (NPV) with a discount rate of 4%), which includes the cost of transportation vehicles, residential and commercial appliances, power plants, fuel production facilities, fuel transportation and the cost of purchasing or extracting primary energy resources. It does not include any equipment or end-use conversion devices in the industrial or agricultural sectors, but does include the costs of supplying energy (natural gas, electricity, etc.) to those sectors. A breakdown of annualized total costs by sector is summarized in Tables E.1 and E.2 for the BAU and GHG-Step scenarios, respectively. The differences in costs between these GHG and BAU scenarios are on the order of 3-15% across scenarios. Cumulative emissions for these four scenarios range from 13.1 GTCO<sub>2</sub>e to 17.4 GTCO<sub>2</sub>e.

**Table 6.1. Summary of undiscounted and discounted (present value at 4% discount rate) energy system costs (in 2010\$) and cumulative emissions for primary CA-TIMES scenarios for 2010 to 2050.**

	<i>Undiscounted Total Cost (2010 to 2050) \$B</i>	<i>Discounted Total Cost (2010 to 2050) \$B</i>	<i>Cumulative Overall<sup>a</sup> Instate Emissions (2010 to 2050) MMTCO<sub>2</sub>e</i>
BAU	8,663	3,472	17,391
BAU-LoVMT	7,945	3,217	16,539
GHG-Step	8,947	3,482	14,278
GHG-Line	9,162	3,550	13,161

<sup>a</sup> Overall Instate Emissions includes out-of-state transportation emissions from aviation and marine modes

Table 6.2 shows the differences in costs and emissions between the GHG and BAU scenarios and the average undiscounted and discounted cost per tonne of CO<sub>2</sub> reduced for the GHG scenarios. We compare the costs and emissions reductions for GHG scenarios with two possible BAUs: the primary Reference scenario (BAU) has higher VMT than the BAU-LoVMT scenario, thus in the BAU scenario more vehicles must be purchased to meet the additional VMT demand. When we compare GHG scenarios with BAU-LoVMT, the GHG benefits will be smaller. At the same time, the total energy system costs in the BAU scenario will be higher than in BAU-LoVMT. Thus there are two trends that increase the cost per tonne estimate when comparing to BAU-LoVMT vs. comparing with BAU: the numerator is getting larger (costs increase) and the denominator is getting smaller (emissions reductions decrease) and hence cost per unit GHG will be higher when comparing with BAU-LoVMT vs. with BAU). In the main scenarios, we treat the LoVMT assumption in the GHG scenarios as an exogenous input and do not estimate the cost associated with VMT reduction. Thus, the cost of reducing emissions (through lower VMT) is implied to be free, whereas in reality, there can be significant costs associated with reducing VMT through infrastructure to supporting walking and bike lanes, public transit systems, etc. The cost of VMT reduction is unknown to us and highly uncertain. Therefore comparing GHG scenarios with BAU *underestimates* the true cost of reducing VMT while accounting for the monetary benefits (reduced vehicle investments and fuel savings). On the other hand, comparing GHG scenarios with BAU-LoVMT

<sup>17</sup> Discounted costs are calculated by using a discount rate of 4% to calculate 2010 present value.

*overestimates* the cost (or underestimates the benefits) since most likely there won't be incentives/policies to reduce VMT under a no climate policy scenario. Also, we do not attempt to quantify the benefits of reducing VMT, such as improved health and quality of life. The "true cost" may be somewhere in between, but it is highly uncertain so at this point, we present both results, recognizing more research is needed for us to better present the true cost estimates of these scenarios.

**Table 6.2. Summary of undiscounted energy system costs (in 2010\$) and cumulative emissions for primary CA-TIMES scenarios for 2010 to 2050.**

	GHG-Step v. BAU	GHG-Step v. BAU-LoVMT	GHG-Line v. BAU	GHG-Line v. BAU-LoVMT
<i>Difference in Undiscounted Total Costs (\$M)</i>	314,105	1,001,674	528,782	1,216,351
<i>Difference in Discounted Total Costs (\$M)</i>	9,270	264,807	77,456	332,994
<i>Undiscounted Cost Difference (\$/resident/yr)</i>	139	503	250	614
<i>Discounted Cost Difference (\$/resident/yr)</i>	-5	140	32	177
<i>Undiscounted Cost Difference (% GSP)<sup>18</sup></i>	0.20%	0.62%	0.33%	0.76%
<i>Discounted Cost Difference (% GSP)</i>	0.01%	0.39%	0.11%	0.49%
<i>Difference in Cumulative Emissions (MMTCO<sub>2e</sub>)</i>	3,113	2,261	4,229	3,378
<i>Undiscounted Cost of emissions reduction (2010\$/tCO<sub>2</sub> reduced)</i>	100.9	443.0	125.0	360.1
<i>Discounted Cost of emissions reduction (2010\$/tCO<sub>2</sub> reduced)</i>	3.0	117.1	18.3	98.6

The differences in energy system cost are between \$314 billion to \$1.2 trillion (or \$9 billion to \$333 billion discounted) over the 40-year modeling period. Compared to projections of state GSP of \$161 trillion (undiscounted) over the modeling period, these incremental energy system costs are all below 1% of state GSP (0.2% to 0.76%). Comparing the discounted incremental costs to discounted GSP over the modeling period yields lower values of below around 0.5% of GSP (between 0.01% to 0.5%). Assuming a lower GSP growth rate does not change the results significantly. At 2% annual growth in GSP, undiscounted incremental scenario costs range from 0.27% to 1.03% and discounted costs range from 0.02% to 0.62% of cumulative GSP from 2010 to 2050<sup>19</sup>.

The differences in cumulative emissions between the GHG scenarios and the BAU scenarios are between 2.2 and 4.2 GTCO<sub>2e</sub>. Comparing the GHG-Step scenario with the Reference BAU scenario, we see that the average cost of reducing a tonne of CO<sub>2e</sub> is \$101 (\$3 discounted), while the average cost of reducing a tonne of CO<sub>2e</sub> from the BAU-LoVMT scenario is \$443 (\$117 discounted). For the GHG-Line scenario, the average cost of reducing a tonne of CO<sub>2e</sub> relative to the Reference scenario is \$125 (\$18 discounted) while the cost rises to \$360/tonne (\$99 discounted) CO<sub>2e</sub> relative to the BAU-LoVMT scenario.

The GHG-Line scenario exhibits somewhat higher mitigation costs relative to BAU but lower costs relative to BAU-LoVMT.

<sup>18</sup> This calculation uses a 3.35% annual GSP growth rate from Moody's baseline scenario (CEC 2013), starting from \$1.88 trillion in 2010 for total undiscounted GSP from 2010 to 2050 of \$161 trillion and discounted GSP of \$68 trillion.

<sup>19</sup> At a lower 2% annual GSP growth rate, GSP from 2010 to 2050 is \$118 trillion undiscounted and \$54 trillion discounted.

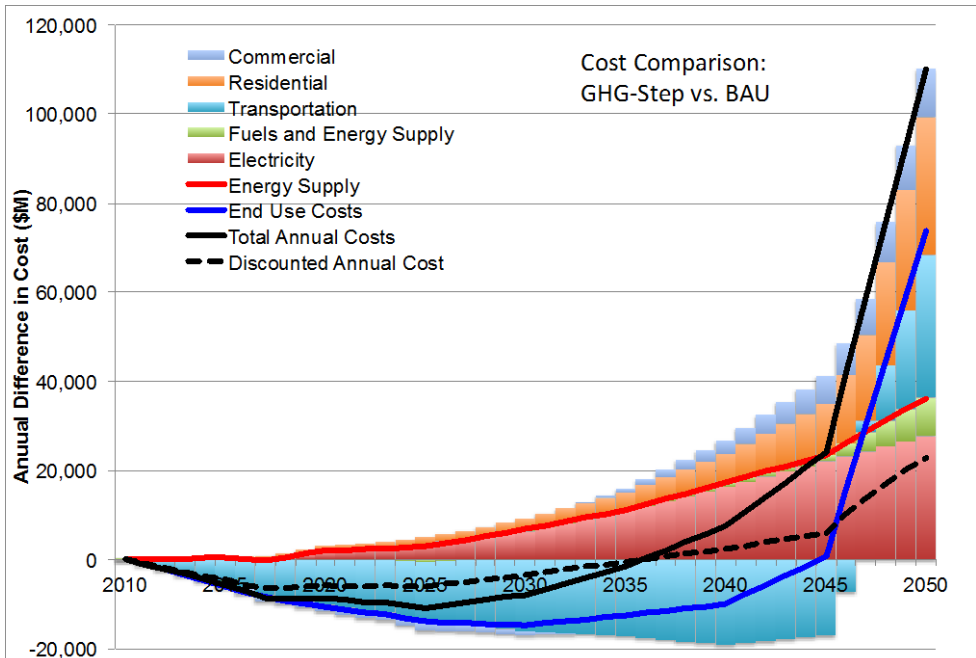


Figure 6.36. Annual cost difference between GHG-Step and BAU scenarios broken down by sector.

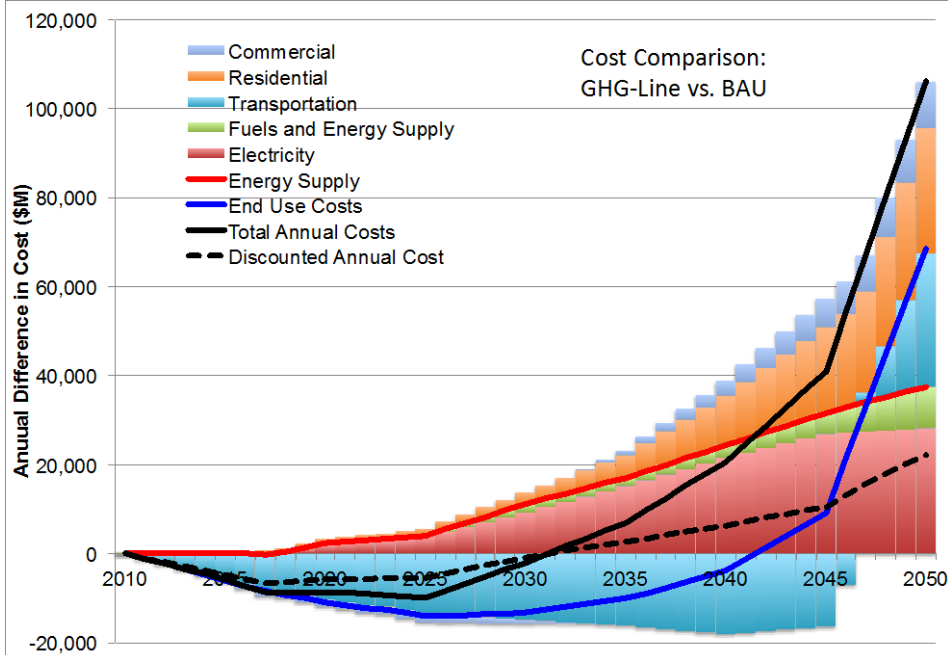


Figure 6.37. Annual cost difference between GHG-Line and BAU scenarios broken down by sector.

Figure 6.36 shows the annual cost difference between the GHG-Step and Reference scenarios. In this graph, transportation costs only include the capital and O&M costs associated with purchasing vehicles (cars, trucks, airplanes, ships, etc.) and not the fuels used to power them. Those fuel costs are included in the “Fuels and Energy Supply” costs or the “Electricity” costs, depending on the type of fuel. The same is true for the other end-use sectors (commercial and residential).

As stated previously, the lower VMT in the GHG-Step scenario relative to the BAU scenario leads to reduced investments in vehicle purchases and negative costs associated with the transportation sector. Even with the reduced VMT in the GHG scenario, transportation expenses for GHG-Step in 2050 are



much greater than in BAU in order to meet the GHG constraint. Because the GHG-Step scenario has greater electricity demand, the costs of building additional power plants makes up the incremental costs seen in the figure. The additional cost of fuels supply is low due to offsetting factors (additional costs associated with supplying low carbon fuels are offset by reduced fuel use associated with renewable energy supplies and more efficient end use technologies). The cost of residential and commercial sectors rises (especially in later years) as more efficient appliances are purchased to help reduce emissions and meet the carbon cap in 2050. Overall, annual cost differences are relatively low (initially negative but within a range of +/- \$20 billion/year, undiscounted) until 2045 when costs rise, reaching over \$100 billion (undiscounted) in 2050 to try and meet the 2050 emissions target. Discounted to present value, the annual costs are relatively modest, becoming positive after 2035 and reach around \$20 billion by 2050. The model discounts future costs at 4% per year and thus high costs in the far future are valued less than similar costs in the near future.

Figure 6.37 shows the comparison of cost for the GHG-Line and Reference scenarios. The magnitude of additional costs are similar for the GHG-Line scenario relative to the GHG-Step scenario but are shifted forward in time, because of the need to meet more stringent intermediate carbon caps. Because the cost of many technologies in the model decline with time, implementing low-carbon and efficient technologies earlier leads to higher annual costs in the middle of the modeling period. Transportation costs are still mostly negative in this figure because of the reduction in vehicle purchases. One thing to note is that CA-TIMES does not consider endogenous technological change and learning-by-doing (where increased adoption during early periods leads to further cost reductions in the later periods) that might be associated with early actions. Therefore, if early actions lead to *more* technological innovation as some policies are designed to incentivize, then the cost could be lower than what we estimate without considering this effect.

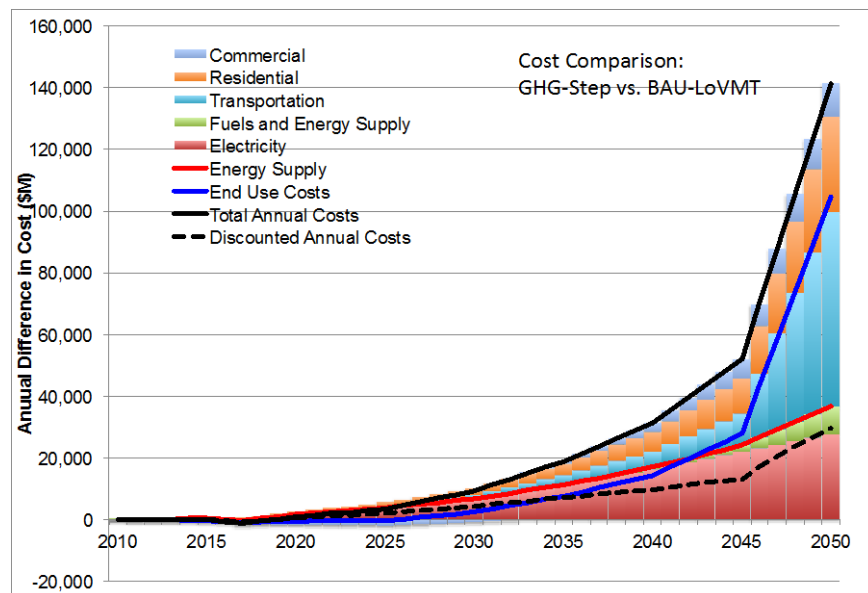
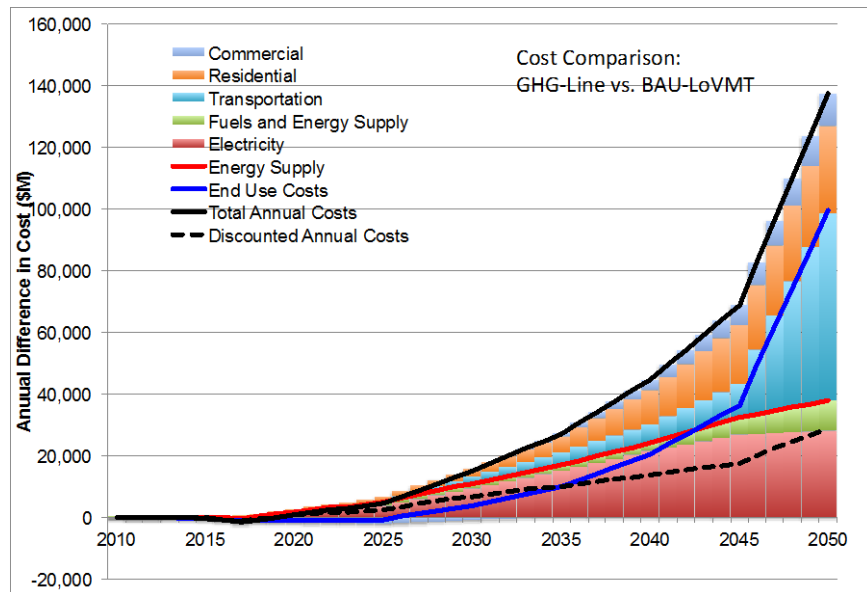


Figure 6.38. Annual cost difference between GHG-Step and BAU-LoVMT scenarios broken down by sector.



**Figure 6.39. Annual cost difference between GHG-Line and BAU-LoVMT scenarios broken down by sector.**

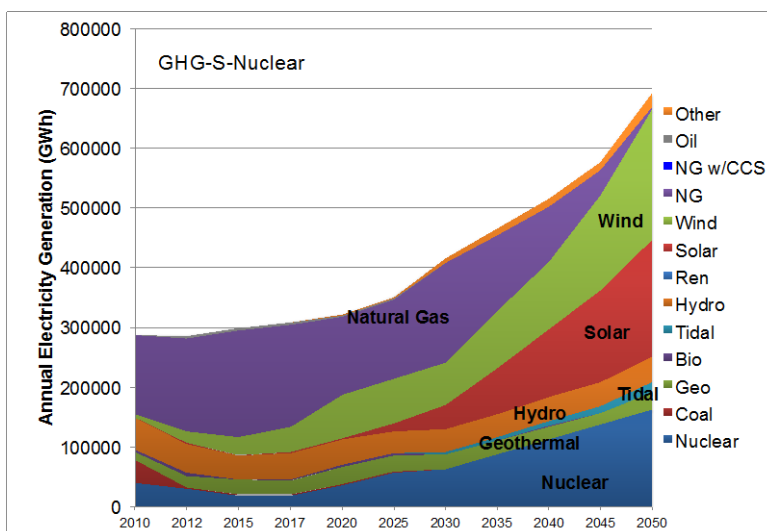
Figure 6.38 and Figure 6.39 show that if you remove the effect of reducing VMT demand relative to the Reference (BAU) scenario, the costs associated with transportation are positive (i.e., more expensive advanced vehicles are needed to meet GHG targets than the BAU-LoVMT scenario). The incremental transportation costs are relatively small until they rise significantly just before 2050. The other costs are all identical or quite similar to the costs differentials relative to the primary Reference scenario. Overall discounted costs are quite low (below \$10 billion/year) to 2045 and then rising to over \$20 billion/yr by 2050.

## 6.2 Sensitivity Scenarios

The results of the CA-TIMES model optimization are strongly dependent on the set of technical and cost assumptions, policy constraints, resource availability and energy prices. Given the difficulty in predicting future trajectories of these parameters, it is helpful to run sensitivity scenarios to understand how the modeling results can change with changes in input assumptions. Unfortunately, as there are thousands of input parameters, it is not possible to explore the full variation on every possible input, so this section will focus on a few key sensitivity scenarios discussed in Section 5.3.

### 6.2.1 New nuclear power

In the primary scenarios, no nuclear power plants can be built due to societal and legislative barriers to nuclear power. This scenario variation removes that constraint and allows for several new types of nuclear power to be built.



**Figure 6.40. Electricity generation by resource type in the 80% Step GHG emissions reduction scenario with nuclear power (GHG-S-Nuclear).**

The primary impact of this scenario is seen in the electricity sector. Comparing the electricity generation mix for the GHG-S-Nuclear scenario (Figure 6.32) to that of the GHG-Step scenario (Figure 6.22), a primary difference is the increase in total electricity generation (692 TWh vs. 600 TWh in 2050) when nuclear power is available. This essentially eliminates any electricity generation from fossil resources as large increase in nuclear power is accompanied by a reduction in natural gas generation (natural gas contributes less than 1% of electricity generation).

While nuclear energy can only be used for producing electricity, it enables the use of a zero-carbon resource in many end-use sectors. The primary GHG scenarios (GHG-Step and GHG-Line) had essentially maxed out the available low carbon electricity supplies that could be used to match demand, and so marginal increases in electricity demand would come from natural gas generation.

The additional electricity generation is used in the commercial and residential sectors where 38% and 51% more electricity is used than in the GHG-Step scenario respectively. The inclusion of nuclear power enables the production of more low-carbon electricity, which allows for greater use of electricity in end-use sectors, displacing emissions from the use of natural gas and other fuels. The carbon intensity of electricity in the GHG-S-Nuclear scenario declines to only 2 gCO<sub>2</sub>e/kWh, much lower than the carbon intensity of electricity in the primary GHG scenarios (~27 gCO<sub>2</sub>e/kWh).

Overall, in-state GHG emissions in the nuclear scenario are able to meet the 2050 GHG emissions target (78 MMTCO<sub>2</sub>e). Meeting the cap on GHG emissions and having a fairly large additional low-carbon energy resource for electricity production allows for the system to relax more expensive mitigation options in other sectors. In the transportation sector, fuel cell vehicle adoption is 43% in 2050 (vs 50% in the GHG-Step scenario) and the remaining 7% of LDVs come from ICEs/HEVs/FFVs, which are non-existent in the primary GHG scenarios.

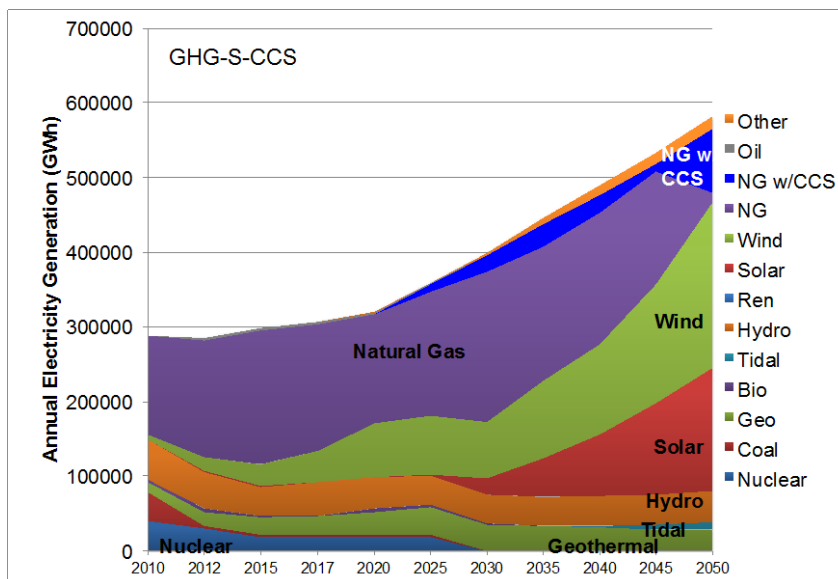
### 6.2.2 Carbon capture and sequestration

Another important technology that is often discussed for carbon mitigation purposes, but is not included in our primary GHG scenarios, is carbon capture and sequestration (CCS). While demonstrations of CCS technology have not progressed as fast as needed, this variant of the GHG-Step scenario (GHG-S-CCS) assumes that development accelerates and that CCS technologies are proven and available to be deployed at scale in the 2025 to 2030 timeframe.

CCS has implications in the electricity and fuels production sectors. In the electric sector, the natural gas combined cycle power plants with CCS account for a significant fraction of total generation in 2050 (15%) displacing much of the conventional natural gas generation (Figure 6.33). The remaining natural gas generation comes from combustion turbines that are needed for highly dispatchable generation in only a few timeslices. The carbon intensity of electricity in this scenario declines to 14 gCO<sub>2</sub>/kWh, compared with 27 gCO<sub>2</sub>/kWh in the GHG-Step scenario. Natural gas combined cycle plants with CCS sequester ~30 MMTCO<sub>2</sub>/yr in 2050.

Perhaps more importantly, for fuels production, biofuels production with CCS is used to create “negative” emissions since some of the carbon in biomass is not returned to the atmosphere but injected into subsurface formations. These negative emissions can then be used to offset emissions from elsewhere in the energy system. In this scenario, all suitable biomass resources are used in Fischer-Tropsch processes with CCS to produce drop-in gasoline, diesel and jet fuel substitutes. Because approximately 2/3 of the biomass carbon can be captured in this process, approximately 83 MMTCO<sub>2</sub>e can be sequestered in 2050 (and which counts as negative emissions). In addition, in this scenario all hydrogen production also utilizes carbon capture and sequestration (2/3 via natural gas reforming and 1/3 via biomass gasification), though this only accounts for well less than 1 MMTCO<sub>2</sub> in 2050.

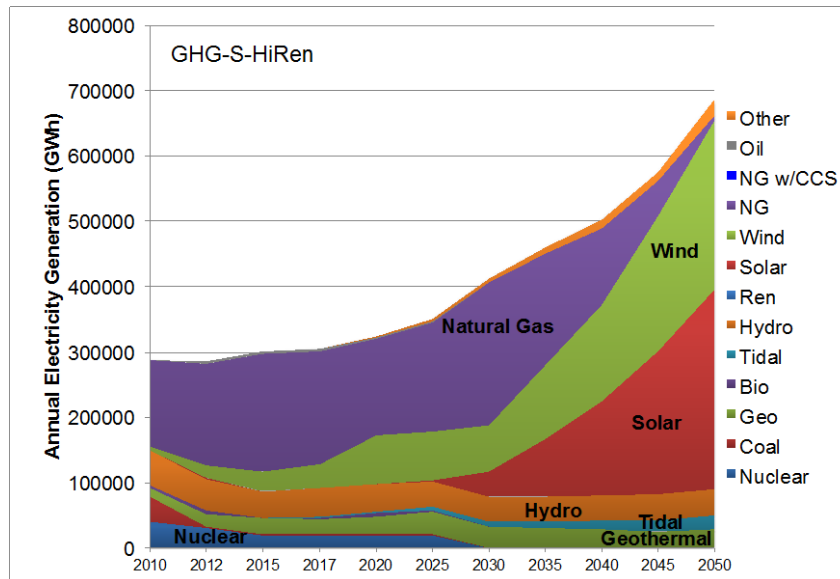
The light-duty vehicle mix is very different from the GHG-Step scenario. In GHG-S-CCS, there is much less use of electricity and hydrogen in the transportation sector in 2050 (BEVs + FCVs account for only 10% of VMT), while ICEs, HEVs and FFVs running on biofuels and petroleum fuels make up the remainder of vehicles (90%). This is because the negative emissions from bioCCS (83 MMTCO<sub>2</sub>e) permits much more use of petroleum than in a scenario without CCS.



**Figure 6.41. Electricity generation by resource type in the 80% Step GHG emissions reduction scenario with carbon capture and sequestration (GHG-S-CCS).**

Overall, the addition of CCS technology in the GHG-S-CCS scenario enables it to meet the 80% reduction target for emissions in 2050 (78 MMTCO<sub>2</sub>e) due to the ability to reduce the carbon intensity of both electricity and fuels and generate negative emissions (via bioCCS). And it enables the state to meet the GHG target with lower cost options that require less significant changes in vehicle technologies (i.e., low carbon liquid fuels vs electrification of vehicles).

### 6.2.3 High renewable electricity growth



**Figure 6.42. Electricity generation by resource type in the 80% Step GHG emissions reduction scenario with higher renewable deployment (GHG-S-HiRen).**

In the primary GHG scenarios, the rate of installation of renewable resources is limited (e.g., utility solar is limited to growing 2 to 3 GW/yr, wind is limited to 3 to 4 GW/yr). In this scenario (GHG-S-HiRen), the rate of renewable deployment is allowed to progress more quickly. In the primary GHG scenarios, as wind and solar bumped up against these limits on the rate of deployment and the remainder of electricity generation came from natural gas power plants. In this scenario, the higher deployment rates allow for greater generation of renewable electricity. Overall electricity generation in GHG-S-HiRen scenario is 685 TWh (and 563 coming from wind and solar) vs. 600 TWh (438 TWh from wind and solar) in the GHG-Step scenario. Like the nuclear scenario, this allows for the displacement of natural gas generation and a reduction in carbon intensity of electricity (to 4 g/kWh in 2050) even as generation rises significantly. The scale of renewable electricity deployment is quite large. From 2010 to 2050, 100 GW of wind power and 143 GW of solar generation are built exclusively to serve California’s electricity demand (vs. 74 GW of wind and 102 GW of solar in the GHG-Step scenario).

And like the GHG-S-Nuclear scenario, adding more low-carbon electricity can help reduce emissions further in 2050 to meet the 80% reduction target (78 MMTCO<sub>2</sub>e). Also as with the nuclear scenario, additional electricity generation is used in the commercial and residential sectors (demand is 30 and 43% higher than GHG-Step respectively) and hydrogen production (1/3 of H<sub>2</sub> comes from electrolysis). The 2050 mix of light duty vehicles is 40% BEV, 10% PHEV, 46% FCV, and 4% ICE/HEV/FFV.

### 6.2.4 Higher biomass supply

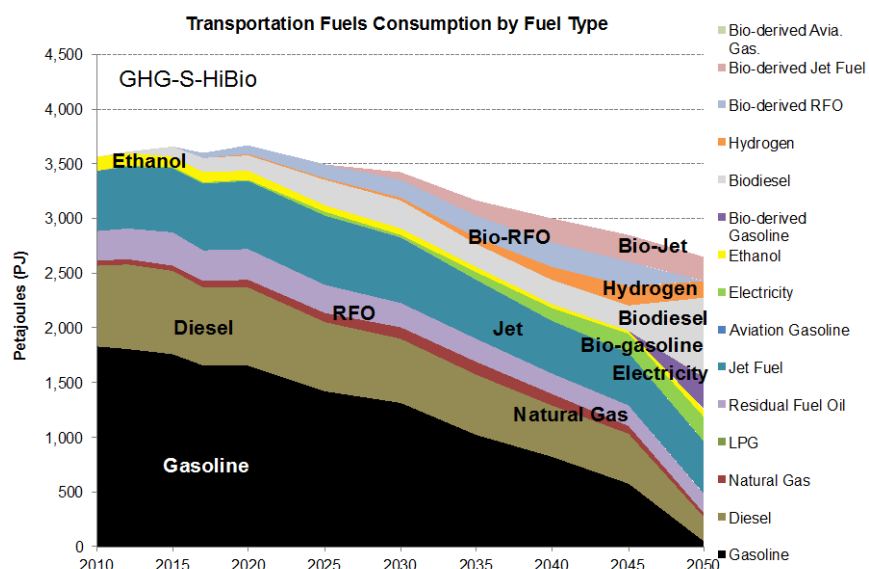
Biomass plays a critical role in the production of biofuels in the GHG scenarios. Reducing emissions from transportation, the largest emitting sector, requires abundant low carbon transportation fuels. Biofuels are one of the primary ways to reduce GHG emissions from transport modes that must continue to use liquid fuels (marine, aviation, heavy duty, etc.). This scenario, GHG-S-HiBio doubles the quantity of available biomass from instate and neighboring regions that can be used in the California energy system. The total biomass available for California in the base case is 1800 PJ, enough biomass to make approximately 1200 PJ (or 9 billion GGE) of biofuels in 2050. This scenario allows 3600 PJ of biomass, enough to make approximately 2400 PJ (18 billion GGE) of biofuels. The supply curve for biomass

shown in Figure 3.4 is essentially stretched out such that there is twice the amount of biomass available at any price.

This large quantity of biomass has an impact in many sectors. However, even with this increase in biomass, biomass is still not used for any electricity generation in 2050. Total electricity generation from all sources in GHG-S-HiBio is lower than GHG-Step (574 TWh vs. 600 TWh). This reduction is due to a substitution of biomass gasification for electrolytic H<sub>2</sub> production and an overall reduction in H<sub>2</sub> demand.

Biomass is used primarily for transportation fuels so that sector has some major differences relative to the primary GHG-Step scenario (Figure 6.36). Light-duty is still highly electrified with 31% FCVs, 40% BEVs and 10% PHEVs, with the remaining 19% ICE vehicles (mostly HEVs). In transportation as a whole, petroleum based fuels decline rapidly comprising only 35% of total fuel use in 2050. Biofuels account for 50% of transportation fuel use and hydrogen and electricity account for 5% and 8%, respectively. Hydrogen in this scenario is made primarily from natural gas, but 1/3 is made from biomass gasification (to meet the 33% renewable mandate). Excluding transportation fuels that are not included in the cap, biomass makes up 75% of total transportation fuels used (and 0% of the transportation fuels excluded from the cap).

There is little change in the mix of technologies or fuel usage in the residential and commercial sectors.



**Figure 6.43. Transportation fuel mix in the High Biomass 80% Step GHG Emissions Reduction Scenario (GHG-S-HiBio).**

Overall, the GHG-S-HiBio scenario meets the 80% GHG reduction goal (78 MMTCO<sub>2</sub>e), 80% below 1990 levels. This model includes an estimate for indirect land-use change impacts associated with some crop-based biofuels to account for emissions from land-clearing (Searchinger, Heimlich et al. 2008).

### 6.2.5 Oil and gas prices

This section describes the impact of two sensitivity scenarios in which the price of oil and gas are higher and lower than the primary scenarios. In the primary scenarios, oil prices rise to \$180/bbl and natural gas to over \$8/MMBTU by 2050. In the high oil and gas price scenario (GHG-S-HiOilGas), oil reaches \$250/bbl and gas rises to \$11/MMBTU in 2050. In the low price scenario (GHG-S-LoOilGas), oil declines to \$70/bbl and gas declines \$3.7/MMBTU in 2050.

Changing the oil and gas prices in the GHG scenarios does not significantly change the mix of technologies that are used to meet the demand for energy. The GHG target is not met in 2050 in GHG-Step, and the main effect of changing the prices associated with energy resources in these scenarios is to influence the total energy system costs, but does not provide fewer or more options for mitigating GHG emissions. The high oil and gas price does very slightly reduce the amount of petroleum fuel vs biofuels but only by about 130 million GGE in 2050 (or around 4% of petroleum usage).

The electricity generation mix and overall energy resource use mix are basically identical from 2010 to 2050 for the GHG-Step, GHG-S-HiOilGas and GHG-S-LoOilGas scenarios).

GHG emissions are still the same in 2050 (96 MMTCO<sub>2</sub>e, a 75% reduction from 1990 levels).

The main effect that these scenarios have is on total energy system costs and the cost of mitigation. As we will show in Section 6.2.7, the impacts on costs is fairly small compared with the other scenarios.

### **6.2.6 Elastic demand (ED)**

While in all other scenarios, energy service demands were specified exogenously as input assumptions (based upon drivers such as population, housing units and commercial floorspace), these two scenarios (GHG-S-Elas1 and GHG-S-Elas2) use a very different approach, described in Section 2.2. Elasticities are specified for each energy service demand within the detailed end-use sectors modeled in CA-TIMES (i.e., transportation, commercial and residential) and for energy demands in the industrial and agricultural sectors (see Appendixes B and C for the assumptions on the elasticity values of the end use services). As described in Section 2.2, rather than minimizing the total system cost of an energy system that can meet the exogenously specified service demand, CA-TIMES-ED computes a partial equilibrium on energy markets where the level of energy service demand responds to changes in the cost of supplying energy services, relative to the Reference scenario. Thus, if the cost of supplying energy services rises, demand will fall by an amount specified by the elasticity. An equilibrium point will be reached where the falling demand will reduce the cost until the point where the cost of supplying the energy service will match the demand for the energy service.

In calculating the equilibrium point, CA-TIMES-ED not only considers system costs (i.e investment and operations) but also the cost of reducing demand which is associated with loss of consumer utility as levels of energy services are reduced.

Two scenarios for elasticity are developed (Elas1 and Elas2). In the first scenario (Elas1), reductions in demand for energy services can be accompanied by a proportional reduction in the end-use equipment/appliances (e.g., vehicles, heaters, light-bulbs) used to satisfy the demand. Each end-use appliance has a certain availability (e.g., miles driven per vehicle or heat output per heater) and from an aggregate perspective, lower levels of demand could be satisfied with fewer appliances. In the second scenario (Elas2), the end-use appliance capacities are constrained to be equal to the non-elasticity case. Thus, even with a reduction in energy service demands, the numbers or capacity of vehicles, heaters and other appliances is fixed. These two scenarios provide bounding cases for understanding the cost and role of demand reduction in GHG emissions mitigation.

In these carbon-constrained elasticity scenario, demand reductions will lead to lower costs, associated with lower fuel and electricity use. In Elas1, it will also lead to cost reductions associated with having to purchase fewer end-use technologies. In either case, reducing demand will also reduce emissions as demand is generally supplied with a mix of fossil and low-carbon resources.

The amount of demand reduction for a given service will be dependent on several things: (1) the value of elasticity for the service demand, and (2) the benefit of reducing demand, which, in turn, depends on the difference between the cost savings of reducing the supply of energy service (e.g., buying less expensive

low-carbon appliances<sup>20</sup> and fuels to meet the demand) and the cost of lost consumer utility (associated with consuming fewer energy services like car travel or air conditioning) and (3) the maximum allowable demand reduction (which is set in this scenario to be 20%). Because this partial equilibrium approach provides another mitigation option (demand reduction) to reduce emissions, the costs of mitigation will be equal to or lower than scenarios without ED.

In the Elas1 scenario, where demand reductions are accompanied with investment cost savings, most demands with elasticity values reduce demand by 20%. The main exception is light-duty VMT, which reduces demand by 12% relative to the LoVMT assumptions in GHG-Step. In the Elas2 scenario, many fewer demands are reduced by the maximum level of 20%. Only a few of the commercial service demands are reduced by 20%, while most of the residential service demands are reduced the maximum level. Light-duty VMT is reduced by 10%. Given our assumption that consumers will still buy exactly the same number/capacity of end use technologies, demand reductions in Elas2 do not result in the same level of cost savings as in Elas1. As a result, elastic demand reduction is not as an attractive an option in Elas2 as compared to Elas1.

The demand reductions in the transportation sector are in addition to the VMT reduction assumptions (LoVMT) in the GHG scenarios. The reductions in service demands are found only in the latter time period, due to the steep cost increases associated with GHG mitigation as the model moves up the technology supply curve.

Total electricity generation in these scenarios are lower than the corresponding GHG-Step scenario (Elas1: 515 TWh, Elas2: 542 TWh vs. 600 TWh) in 2050. Because total demand is lower, the limited wind and solar resources can provide a greater fraction of total electricity generation. Natural gas generation in 2050 only accounts for 1-2% of electricity generation in the elasticity scenario vs. 8% in GHG-Step. The same is true of transportation fuel demands, which, in GHG-S-Elas1 is 5% lower and GHG-S-Elas2 is 6% lower than the GHG-Step scenario, and thus biofuels can make up 40-41% of transport fuels instead of 37% in GHG-Step.

Ultimately, a model with elasticity on demands will be a more realistic representation of decision-making and energy usage in response to rising prices. However, modeling demand reduction is relatively new in the field and there is some uncertainty surrounding how to model consumer behavior, particularly the elasticity values of service demand (as opposed to fuel use demand that is more commonly measured in the econometric literature) to prices, and the interactions between demand shifts and purchasing decisions (Elas1 vs. Elas2). These representations of demand reductions within CA-TIMES are a simplified representation of real world consumer behavior, and the results are preliminary. More work is ongoing to improve our understanding of demand elasticity, and the appropriate representation in an optimization model.

### **6.2.7 Comparison between sensitivity scenarios**

Figure 6.44 shows a comparison of the cumulative GHG emissions and GHG emissions reductions from 1990 levels for two sets of emissions categories (*Included Instate* and *Overall Instate*) for the various sensitivity scenarios presented in this section. The Reference (BAU) scenario has the highest cumulative emissions for both emissions categories and the lowest level of reduction from 1990 levels in 2050. Many of the low-carbon resource scenarios meet the 80% reduction target (GHG-S-CCS, GHG-S-NucCCS, GHG-S-Nuclear, GHG-S-HiRen, GHG-S-HiBio) as well as the two elasticity scenarios (GHG-S-Elas1 and GHG-S-Elas2). The GHG-Line scenario has the lowest cumulative emissions of any scenario, even

---

<sup>20</sup> Only applies for the Elas2 scenario.

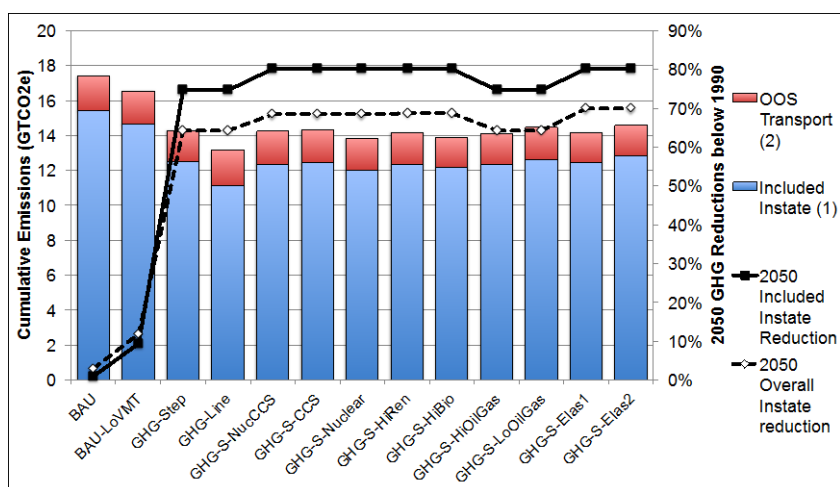


though it is unable to achieve the 80% reduction in GHG emissions by 2050. This has to do with the earlier schedule of emissions reductions relative to all of the other scenarios based upon the “Step” cap.

Of the scenarios based upon the “Step” cap, the GHG-S-Nuclear scenario has the lowest cumulative emissions due in part to the assumed readiness of the technology to be deployed, relative to other mitigation options, such as CCS. The scenario with the highest cumulative emissions is the GHG-S-Elas2 scenario. In CA-TIMES, demand reduction can ramp up instantly to provide large GHG benefits. As a result, the model is less inclined to invest in GHG mitigation options and the vast majority of demand reduction is implemented in 2050 just in time to meet the significantly lower 2050 cap.

The level of emissions from Out-of-state transportation (shipping and aviation) emissions are relatively similar between scenarios, since they are not included in the emissions cap, there is little incentive to decarbonize these sectors. In addition, the model does not consider offsets option in any of the GHG scenarios. Therefore, our 80% GHG scenario can be considered more stringent than the implementation plan adopted by CARB.

The two primary GHG scenarios (GHG-Step and GHG-Line) reduce *Included Instate* emission by 75%, though *Overall Instate* emissions by only 64%. Several other scenarios (GHG-S-HiOilGas, GHG-S-LoOilGas) have the same level of GHG reductions, since these sensitivity scenarios do not change the availability of low carbon resources or technologies, only their costs.



**Figure 6.44. California cumulative GHG emissions (from Included and out-of-state transport sources) and 2050 emissions reduction from 1990 levels.**

Figure 6.45 shows the emission trajectories of these scenarios over time. The emission levels in 2030 range from 286 MMTCO<sub>2</sub>e in the GHG-Line scenario to 341 MMTCO<sub>2</sub>e in the GHG-S-Elas2 scenario.

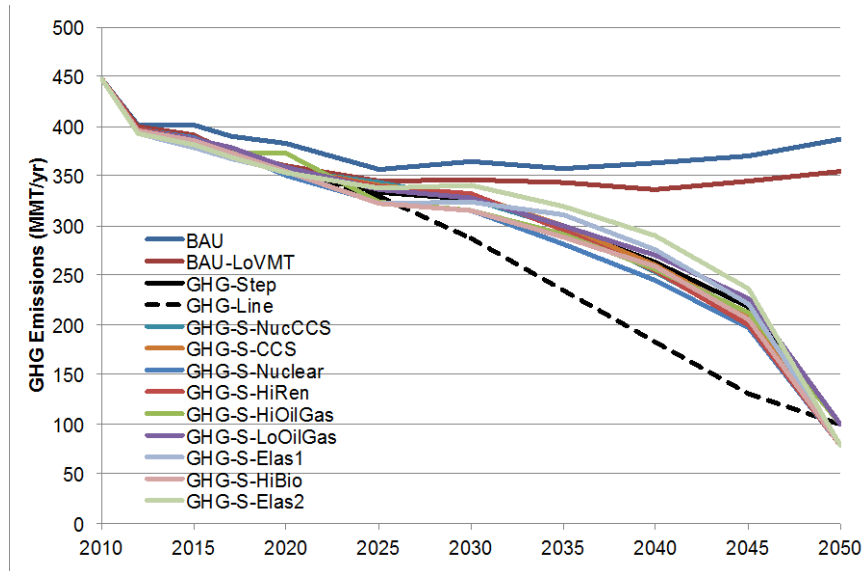


Figure 6.45. California annual GHG emissions and 2050 emissions reduction from 1990 levels.

Figure 6.46 shows the primary energy resource mix for each sensitivity scenario. The GHG scenarios all have lower primary energy usage than the BAU scenarios indicating that improved efficiency (above and beyond what is achieved in the BAU scenario) is one of the primary means of reducing emissions. Total primary energy consumption for the GHG scenarios ranges from 10 to 25% below the BAU scenario and 5 to 23% below BAU-LoVMT scenario. The elasticity scenarios have additional reductions in service demand so total energy use is significantly lower (20-27% below the two BAU scenarios and 14-16% below GHG-Step).

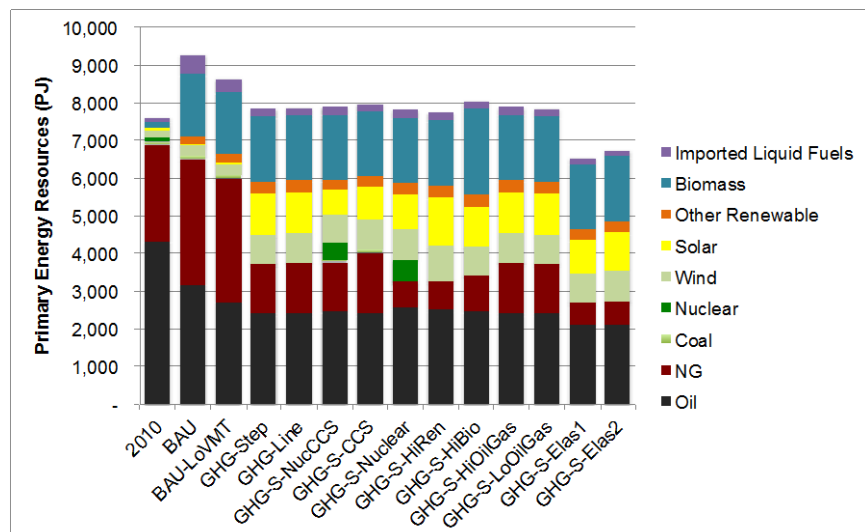
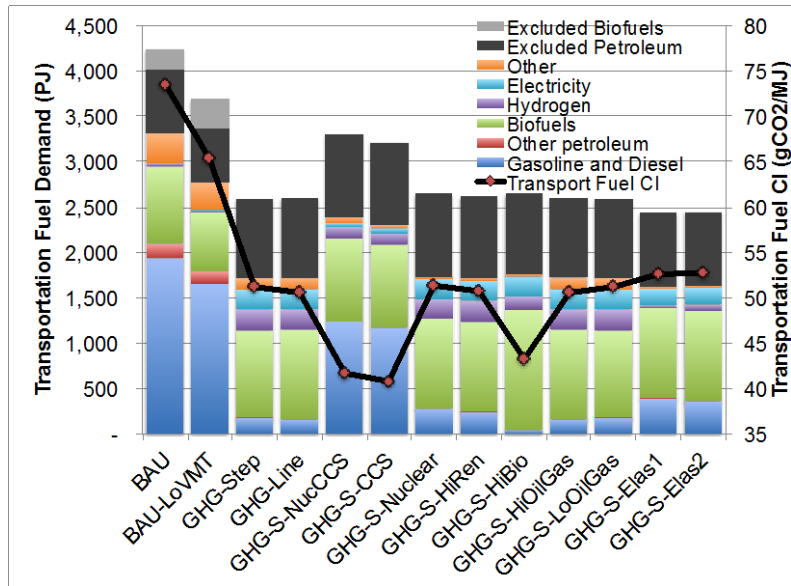


Figure 6.46. California primary energy resource usage by sensitivity scenarios (for 2050).



**Figure 6.47. California transportation fuel usage and carbon intensity by sensitivity scenarios (for 2050).**

Figure 6.47 shows the mix of transportation fuels used in the various sensitivity scenarios in 2050, including fuels for out-of-state aviation and marine travel. Interestingly, if one only considers in-state travel, petroleum usage (gasoline, diesel and other petroleum) declines to almost zero, accounting for just 180 PJ (1.4 billion GGE) in the GHG-Step and GHG-Line scenarios, compared with 2100 PJ (16 billion GGE) in the BAU scenario. Including interstate/international aviation and marine fuels, changes the picture dramatically; GHG-Step petroleum usage increases to 1050 PJ (8 billion GGE) vs 2800 PJ (21 billion GGE) in BAU. The scenarios with CCS (GHG-S-CCS and GHG-S-NucCCS) use negative emissions from bioCCS to offset emissions from continued use of petroleum for In-state travel. These scenarios have around 1200 PJ (9 billion GGE) of petroleum use just under the emissions cap, in addition to the petroleum fuel used for out-of-state travel. The two elasticity scenarios also further reduce fuel use via demand reduction and the associated GHG reduction enables the use of more petroleum fuels under the cap (up to 400 PJ or 3 billion GGE). The average carbon intensity (CI) of transportation fuels declines below 55 g/MJ in all of the GHG scenarios in 2050. The scenarios with the lowest fuel CI (41-42 g/MJ) are those with CCS since the use of bioCCS can produce biofuels with negative CI. Higher quantities of biofuels in GHG-S-HiBio also reduce carbon intensity 43 g/MJ. These average CI values for all transportation fuels include significant petroleum usage for out-of-state travel. The CI of fuels for out-of-state aviation and marine travel are all well above the average at around 60-70 g/MJ, whereas the CI of liquid fuels used for in-state travel are all between 28 and 50 g/MJ.

Figure 6.48 shows California's electricity generation mix in 2050 for all the sensitivity scenarios. Many of the GHG scenarios look remarkably similar, with most electricity coming from wind and solar, with contributions from natural gas, hydropower, tidal, geothermal and other. The carbon intensity of electricity in all of the GHG scenarios declines significantly from 350 gCO<sub>2</sub>/kWh in 2010 to between 2 and 30 gCO<sub>2</sub>/kWh in 2050. Carbon intensity of electricity depends primarily on the percentage of natural gas generation in the mix, since all other generators are very low to zero carbon. The scenarios that deviate from this base electricity mix are those with new electric generation resources available, including nuclear power (GHG-S-Nuclear), CCS (GHG-S-CCS), both nuclear and CCS (GHG-S-NucCCS), and higher deployment of wind and solar (GHG-S-HiRen). The supply of low-carbon electricity generation is at its limit in most of the scenarios, so additional demand for electricity would come from natural gas. The two scenarios with higher electricity demand are the ones where there are additional low carbon electricity sources available (GHG-S-Nuclear and GHG-S-HiRen) and carbon intensity is also lowest at 2 to 4 gCO<sub>2</sub>/kWh. The GHG-S-CCS, GHG-S-Elas1, GHG-S-Elas2 and GHG-S-HiBio scenarios have

lower electricity demand because other options are available to reduce emission beyond low carbon electricity, namely negative emissions with bioCCS, demand reduction and additional biofuels respectively. The elasticity scenarios also have quite low electricity carbon intensity (4-7 gCO<sub>2</sub>/kWh) because reduced electricity demand means that a greater percentage of demand can be met by wind and solar resources.

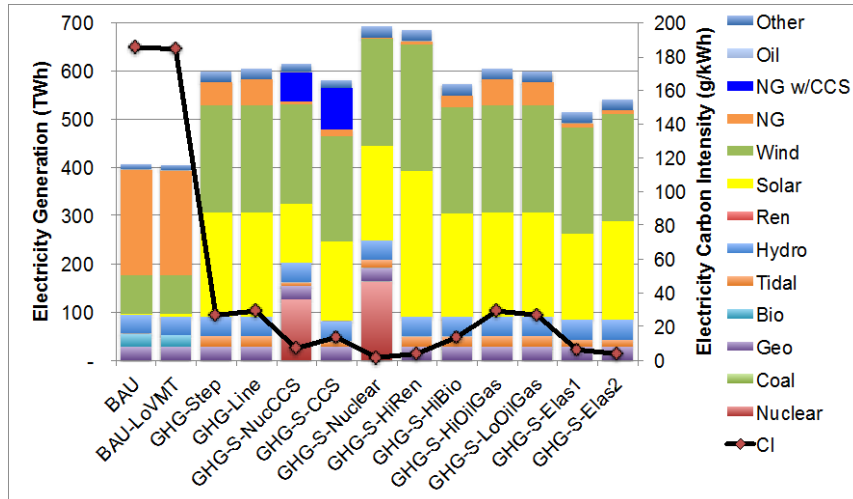


Figure 6.48. California electricity generation mix and carbon intensity by sensitivity scenarios (for 2050).

Figure 6.49 shows California’s LDV fleet mix in 2050 for the different sensitivity scenarios. Again, many GHG scenarios are very similar to the GHG-Step scenario. The scenarios with the greatest difference are the two that have CCS (GHG-S-CCS and GHG-S-NucCCS), where the use of negative emission biofuels allows the GHG target to be met with many fewer FCVs and almost no PEVs. The elasticity scenarios also exhibit significant reductions in the use of electric-drive vehicles, as GHG mitigation can come from demand reduction rather than more expensive FCVs.

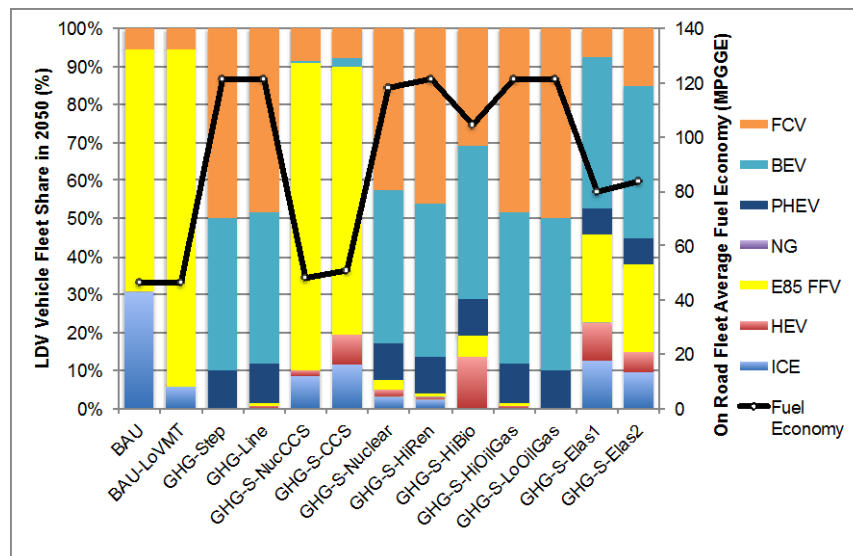


Figure 6.49. California light-duty vehicle fleet share by sensitivity scenarios (for 2050).

Table 6.3 shows the cumulative emissions, total costs and emissions and cost differences for each of the sensitivity scenarios. Costs for mitigation are always higher when comparing to the BAU-LoVMT scenario than the BAU scenario because the lower VMT will lead to a smaller difference in cumulative

VMT. The cost of mitigation relative to the primary Reference (BAU) scenario can be a little misleading if there are actually costs associated with the VMT reductions that are assumed in the GHG scenario. These costs are also compared in Figure 6.50.

**Table 6.3. Table of cumulative emissions, total system costs and cost and emissions differences for various sensitivity scenarios.**

	<i>Cumulative Included Instate Emissions</i> <i>MMTCO<sub>2</sub>e</i>	<i>Cumulative Overall Instate Emissions</i> <i>MMTCO<sub>2</sub>e</i>	<i>Undiscounted Cost</i> <i>\$B</i>	<i>Discounted Cost</i> <i>\$B</i>	<i>Cumulative Included Instate Emissions Difference</i>		<i>Avg Cost of Emissions reduction (\$/tCO<sub>2</sub>e) undiscounted</i>		<i>Avg Cost of Emissions reduction (\$/tCO<sub>2</sub>e) discounted</i>	
					<i>vs BAU</i>	<i>vs BAU-LoVMT</i>	<i>vs BAU</i>	<i>vs BAU-LoVMT</i>	<i>vs BAU</i>	<i>vs BAU-LoVMT</i>
BAU	15,405	17,391	8,633	3,472	-	-	-	-	-	-
BAU-LoVMT	14,663	16,539	7,946	3,217	-	-	-	-	-	-
GHG-Step	12,475	14,278	8,947	3,482	3,113	2,261	101	443	3	117
GHG-Line	11,094	13,161	9,162	3,550	4,229	3,378	125	360	18	99
GHG-S-NucCCS	12,352	14,229	8,070	3,237	3,162	2,310	-178	54	-75	9
GHG-S-CCS	12,440	14,301	8,139	3,254	3,089	2,238	-160	86	-71	17
GHG-S-Nuclear	12,019	13,821	8,452	3,337	3,569	2,718	-51	186	-38	44
GHG-S-HiRen	12,343	14,148	8,682	3,396	3,242	2,391	15	308	-24	75
GHG-S-HiBio	12,161	13,878	8,780	3,431	3,513	2,661	42	314	-12	81
GHG-S-HiOilGas	12,340	14,107	8,975	3,493	3,283	2,432	104	423	6	114
GHG-S-LoOilGas	12,620	14,454	8,931	3,476	2,937	2,085	101	472	1	124
GHG-S-Elas1	12,438	14,151	8,743	3,414	3,240	2,388	-234 (268)	-30 (364)	-95 (77)	-21 (104)
GHG-S-Elas2	12,809	14,583	8,767	3,425	2,808	1,956	-94 (142)	216 (204)	-51 (34)	58 (48)

Mitigation cost values in parentheses represent non-monetary loss of consumer utility from reduced energy service demands

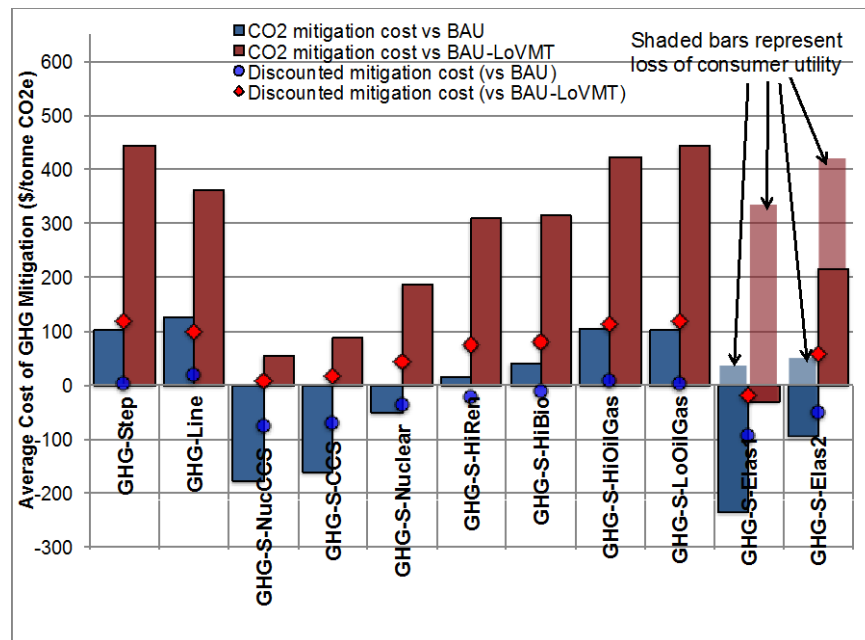
The GHG-Step and GHG-Line scenarios have average undiscounted CO<sub>2</sub> mitigation costs that range from \$101 to 125/tCO<sub>2</sub>e vs the BAU scenario and from \$360 to \$443/tCO<sub>2</sub>e vs the BAU-LoVMT scenario. Discounting the costs at 4% discount rate lead to relatively low present value of mitigation costs (\$3 to \$18/tCO<sub>2</sub>e vs the BAU scenario and from \$99 to \$117/tCO<sub>2</sub>e vs the BAU-LoVMT scenario) because the incremental costs are typically higher in later years. Mitigation costs are higher for when comparing to the BAU-LoVMT scenario because the reduction in VMT (and associated GHG reduction) is not assumed to be free, as is the case when comparing with BAU scenario. Mitigation costs are similar between the two GHG scenarios. GHG-Line has higher costs than GHG-Step because of earlier investments in low-carbon technologies and resources but also has greater reductions in cumulative GHG emissions. These factors offset somewhat leading to similar costs.

The addition of reasonably low-cost, low-carbon technologies such as nuclear or CCS enables significant cumulative emissions reductions at relatively low average cost (negative discounted costs when compared with BAU (-\$75 to -\$38/tCO<sub>2</sub>e) and from \$9 to \$44/tCO<sub>2</sub>e in comparison to BAU-LoVMT). The availability of CCS especially leads to lower mitigation costs because CCS is assumed to be a relatively low cost mitigation option, especially when coupled with biomass gasification plants to produce negative emissions. The renewable scenario (GHG-S-HiRen) and biomass scenario (GHG-S-HiBio) also have relatively low cost mitigation costs (discounted costs of -\$24 to -\$12/tCO<sub>2</sub>e vs BAU and \$75 to \$81/tCO<sub>2</sub>e vs BAU-LoVMT) associated with low-cost, low carbon resources that can effectively displace higher carbon resources (nuclear for natural gas generation and biofuels for petroleum resources). The impact of the various cost scenarios on mitigation costs is relatively small (similar to GHG-Step).

The elastic demand scenarios also have fairly low mitigation costs among the sensitivity scenarios. GHG-S-Elas1 has the lowest costs when taking into account only energy system costs. When also accounting for the costs associated with loss of consumer utility, the cost of mitigation rises to be similar to the primary GHG scenarios. GHG-S-Elas2, is constrained to have a greater capacity of end-use appliances than GHG-S-Elas1 (but at the same level as GHG-Step), and as a result the reduction in mitigation costs is not as large as Elas1 scenarios, and demand reduction is lower. Overall, given the higher investment

requirements for Elas2, the mitigation costs are higher. In Figure 6.50, the utility losses are represented in the elastic scenarios as shaded bars (costs are also shown in parentheses in Table 6.3). These costs representing loss of consumer utility are not real expenditures, so we present costs with and without these utility losses for comparison to scenarios without elastic demand. While consumers do not have to incur monetary costs for reducing demands, there can be real welfare losses associated with reducing VMT, and energy services in our homes and commercial spaces.

Future work will focus on a better understanding of elasticity and demand reduction in response to climate mitigation and the best way to value changes in demand. For the time being, these scenarios are used to illustrate the potential technology savings in GHGs as well as reduced investments in expensive advanced technology. Also, as we noted earlier comparing GHG scenarios with BAU *underestimate* the true cost as VMT reduction is assumed to be free in the current version of the model. On the other hand, comparing GHG scenarios with BAU-LoVMT likely *overestimates* the cost (or underestimates the benefits) since most likely there won't be incentives/policies to reduce VMT under no climate policy scenario. So in reality the "true cost" may be somewhere in between these two estimates and we recognize that more research will be needed for us to better present the true cost estimates of these scenarios.

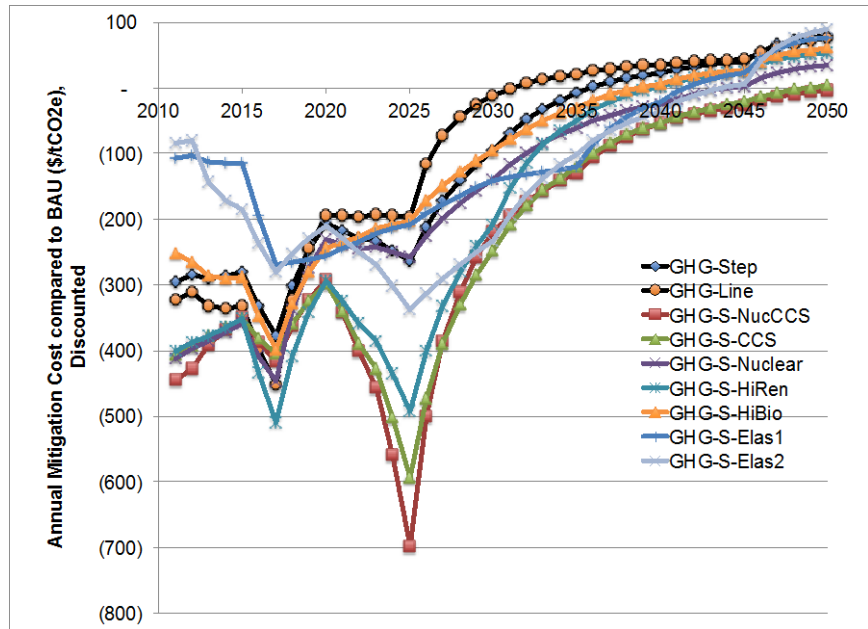


**Figure 6.50. Average cost of emission reduction (\$/ton CO<sub>2</sub>) between 2010-2050 comparing with BAU and BAU-LoVMT scenario.** Also shown are the discounted costs (r=4%) compares with BAU (blue dots) and with BAU-LoVMT (red diamonds).

Figure 6.51 shows mitigation costs by scenario over GHG emission reductions (and also over time as more GHG emissions are reduced each year by 2050). The large negative costs in the near term primarily reflect cost savings resulting in the lower VMT demand and lower investments in light-duty vehicles. They also represent some cost savings associated with efficiency improvements that are induced by policies (to overcome the “efficiency gap”).

These early negative costs are replaced by positive costs somewhere between 2030 and 2050 depending upon the scenario, resulting from the need to further reduce GHG emissions and the need to invest in more expensive, more efficient technologies and fuels to do so. Discounting these costs back to present value (2010\$) means that these later high costs (up to \$400/tCO<sub>2</sub>e) are not that expensive (up to \$80/tCO<sub>2</sub>e discounted at 4%).

The figure indicates that certain low-cost, high impact technologies, such as nuclear and CCS (GHG-S-CCS, GHG-S-Nuclear, and GHG-S-NucCCS) lead to the lowest mitigation costs out to 2050.



**Figure 6.51. GHG mitigation costs vs BAU, discounted by scenario over GHG scenarios.** Elasticity scenarios include consumer utility loss associated with reduced service demand.

## **7. NON-CORE EXPERIMENTAL TIMES MODELS/SCENARIOS**

This section describes several innovative stand-alone models that use TIMES algorithm (cost-minimization) but are currently too computational intensive to be included in CA-TIMES v1.5. These new modeling techniques demonstrate areas that we consider critical for improving upon the existing model. We demonstrated how these improvements can be made and the expected results. We expect to incorporate these new methodologies, or will develop simpler approaches to incorporate these new modeling techniques into the main model in the future. See Appendix F for more details on these experimental modeling approaches.

### **7.1 Hydrogen Infrastructure Model**

A stand-alone hydrogen-only model (H2TIMES) has been developed to simulate the development of hydrogen infrastructure in California using the TIMES modeling framework. It attempts to build the least cost H<sub>2</sub> infrastructure needed to meet an exogenously specified demand for hydrogen in 8 regions of the state. More information can be found in the detailed paper (Yang and Ogden 2013). The goal of the H2TIMES modeling is to develop a policy relevant, spatially-representative detailed hydrogen infrastructure transition optimization model for California. The purpose of the analysis is to understand the context and influence of different policies on the development, cost and emissions associated with hydrogen deployment in California. H2TIMES has a special focus on low-carbon and renewable hydrogen futures by 2050.

Hydrogen demand and, consequently, infrastructure development is distributed among eight regional clusters to account for differences in hydrogen demand density and total demand in different regions of the state, which will influence the cost of hydrogen production and delivery. A regional clustering approach was used to split the state into these regions and calculate the pipeline and hydrogen truck delivery distances needed to delivery hydrogen to a network of refueling stations in each cluster.

Another important element to this analysis is that many of the key elements and components that make up hydrogen infrastructure have important economies of scale (e.g., central hydrogen production and liquefaction plants, pipeline networks and refueling stations). However, the TIMES framework relies on linear programming and two issues typically arise with the typical TIMES approach to costs: (1) capital costs are proportional to capacity and (2) the model can invest in any amount of capacity, even unrealistically small sizes. The novel modeling approach taken here couples discrete investments with continuous capacity additions, to simulate declining costs with increasing scale (i.e., economies of scale).

This modeling approach allows for more accurate representation of the spatial parameters and scale economy of hydrogen infrastructure, coupled with the policy modeling of carbon intensity constraints, state renewable hydrogen policy and other relevant policies. This approach will be incorporated into the full CA-TIMES model at a later date.

### **7.2 Consumer Choice Model for Light-Duty Vehicle**

A stand-alone consumer choice model of light-duty vehicle purchases is being developed to better incorporate non-economic factors into the model decision-making. An illustrative model, COCHIN-TIMES (COConsumer CHOICE INtegration in TIMES) is developed to model the light-duty vehicle sector for California. A vehicle choice model (MA<sup>3</sup>T: Market Allocation of Advanced Automotive Technologies) developed by Oak Ridge National Laboratory is used as a primary data source for consumer preference and utility data in the COCHIN-TIMES model (Zhenhong Liu 2010). The model attempts to bring in heterogeneity into the decision making process to account for distinct preferences of different consumer groups. The exogenously-defined end-use demand in the TIMES model (i.e., light-duty VMT) is disaggregated into 27 separate consumer groups and each consumer group is further divided into fixed number of slightly varying instances in order to capture heterogeneity and variation among car buyers.



Data from the MA3T model, a nested multinomial-logit model developed by Oak Ridge National Laboratory is used for predicting the penetration rates of advanced vehicle technologies in the US. Costs that are considered in the model consist of tangible costs (like vehicle purchase price and fuel costs) as well as intangible costs (such as disutility associated with limited vehicle range, limited refueling station availability, new technology risk premiums and low model availability).

Preliminary runs of the model allow the TIMES model to incorporate a much more diverse set of consumer choices, as compared to the “winner take all” behavior of typical energy system models. This modeling approach allows for better representation of non-economic factors that influence vehicle purchase and the heterogeneity in the pool of decision-makers (i.e., new car and truck buyers). Future work includes incorporation into the full CA-TIMES model as well as improved representation of endogenous utility costs as advanced technologies are deployed.

### **7.3 Flexible Plug-in Electric Vehicle Charging**

The environmental impact of plug-in electric vehicles (PEVs) will depend upon the electricity generation sources that are used to charge these vehicles. And as discussed in the electricity generation section, the mix of electric power plants and therefore the cost and emissions from electric generation all change as a function of timeslice. In addition, PEVs are parked more than 90% of the time so there is significant potential for flexibility in the timing of recharging these vehicles.

One benefit to electric vehicles is that charging electric vehicles when other demands are lowest can improve overall capacity factors for power plants on the grid and lower the cost of electricity generation. Flexibility in vehicle charging is also important and electric vehicle owners have been shown to alter their charging patterns in response to time-of-use (TOU) prices.

This approach will allow the model to determine the best timeslices to charge vehicles with respect to overall system cost and operation. Allowing the model to determine when charging occurs can improve capacity factor of existing and future power plants and allow the model to build and operate lower cost baseload plants rather than more expensive peaking power plants. Another important benefit to flexibility relates to the generation of intermittent renewables. If there is an abundance of wind or solar generation during specific times of day, the model could choose to charge during these hours and utilize cheap or even excess renewable generation. However, even with incentives, not all consumers will be able or willing to limit their charging to suite the best interests of the electric grid. Thus, the approach taken here is that some fraction of vehicle charging demands can be assumed to follow a fixed profile while the remaining charging demand can be optimized by the model to minimize costs and the fraction of fixed vs. variable charging can change over time.

## **8. SUMMARY, CONCLUSIONS AND FUTURE WORK**

California has taken the first steps towards strong policy action to reduce GHG emissions in the near-term (i.e., 2020). However, considerable uncertainty still exists about the options, resources and technologies that will be used to meet the longer-term goals of deep reductions in GHG emission by 2050 and beyond. These reductions by 80% or more are needed if the state and the rest of the world are to adequately address and mitigate the worst impacts from climate change. California's policy suite has a near-term focus but the frameworks are in place to extend these policies and increase stringency in order to meet the 80% reduction target in 2050.

CA-TIMES is a model of the California energy system and incorporates a representation of the technologies and resources/fuels used in energy supply and demand sectors with rich bottom-up technological detail. The model is used to simulate investments in infrastructure and end-use technologies that are needed to meet the demand for energy and scenarios are developed to analyze changes in these investments in response to different policy, technology and resource assumptions.

The major energy system transformation that will be needed to meet these goals is still uncertain, in terms of the resources and technologies that will need to be brought to bear, the policies that will induce these major shifts and the social aspects of major transformations. The CA-TIMES model focuses primarily on the first two aspects: gaining a better understanding of the resources and technologies that can help reduce emissions and the policies that are needed to bring them about. A number of variations of the 80% GHG reduction scenario are run showing that the future energy resource and technology mix can vary quite significantly depending on model assumptions.

### **8.1 Discussion of modeling approach**

The scenarios and modeling results presented in the last section provide a small glimpse into the wide range of possible model scenarios, input assumptions, and system approaches that are possible to explore with the CA-TIMES model. As such, the CA-TIMES model structure and scenarios in this study represent one step in the model development and scenario analysis process.

The CA-TIMES scenarios investigated how the California energy system might meet an 80% reduction in greenhouse gas emissions below 1990 levels by 2050. These scenarios are different from other scenario planning processes (such as those developed by Shell or the recent scenario analysis co-developed by LBNL and CARB; Greenblatt (2013)) where story lines are developed to illustrate possible ranges but costs and interactions between sectors at the system level are not explicitly considered. CA-TIMES meets the demand for energy services by finding the right portfolio of energy supply, conversion, end-use technologies, and, in two experimental cases, demand reduction by minimizing the total system cost or maximizing total system utility within a set of assumptions and constraints.

The CA-TIMES model essentially acts as a global decision-maker with perfect foresight, whose goal is to minimize the cost of meeting energy demands for the entire modeling period (or maximizing utilities when elastic demand reductions are included). It uses a discount rate of 4% to value inter-temporal costs, thus valuing costs in the future less than in the near-term.

Because the goal is to minimize the net present values of the total system cost, the model makes trade-offs across all aspects of the energy system to meet the target, which is the most powerful feature of the CA-TIMES model. In essence, the model compares the cost of GHG reduction from different options at the lowest system cost. For example, CA-TIMES may find that it is cheaper to reduce emissions by investing in wind power than by investing in electric vehicles. This can be thought of as an extremely efficient carbon market, where the cost of reduction in all technologies is known and tradable, although CA-TIMES does not actually represent a carbon market within the model.

The CA-TIMES modeling approach identifies the least-cost option to meet the stated policy goals, given the assumptions and constraints of the model. Given the modeling simplification described previously, the results are useful scenarios of what the world could look like if the market is extremely efficient and all current and future costs and demands are perfectly known and tradable at zero transaction costs. There will be, however, deviations from this ideal model behavior and how real world investments are likely to unfold. It is then up to the policy-maker to try to implement policies that bridge the gap between the ideal world in CA-TIMES and the real world where a full carbon market across all sectors does not exist, costs are not always well-known and evaluated as such, and other factors other than GHG emission reductions need to be considered (e.g., other sustainability impacts such as air quality, equity, etc). It is in this context of these considerations that all of the modeling results presented should be understood.

## 8.2 Summary of Results and Conclusions

The main application of the model is to develop and analyze scenarios for how California's energy system could potentially evolve over the next several decades, in light of strong policies to reduce energy use and GHG emissions. Some robust conclusions of the modeling:

### *Overall GHG reduction:*

The GHG scenarios presented in the results section show that achieving an 80% reduction in GHG emissions relative to 1990 emissions in California requires major transformations in the energy system. On the supply side, the most notable changes include major investments in renewable electricity generation, biofuel production, and hydrogen production. On the demand side, these change include substantial efficiency improvements across all sectors, including investment in battery electric and fuel cell vehicles, more efficient trucks, buses and planes, and major reductions in building energy use through efficient appliances. All of the GHG scenarios run in CA-TIMES achieve a deep reduction in GHG emissions by 2050 (between 75% and 80% below 1990 GHG emissions) though the mix of resources, technologies and emissions reductions by sector and associated costs vary by scenario.

Even with these changes, the primary GHG scenarios fall just short (75%) of the 80% GHG target (including emissions from imported electricity, and no offsets). These two scenarios fall short of the target because of a lack of additional low-carbon resources that can be used to further reduce emissions. Because the transportation sector is the sector with the largest remaining emissions, additional sources of low-carbon transportation fuels (via electricity, biofuels, hydrogen and CCS) are an obvious way to enable further GHG mitigation.

The two main GHG reduction scenarios exhibit very different timing of emission reductions (the "Step" and "Line" scenarios) but show identical technology and resource mixes in 2050 due to the need to minimize GHG emissions. Deployment rates of low-carbon technologies are, in general, earlier for the "Line" scenario, which also leads to lower cumulative emissions over the modeling period than a cap with no interim targets (GHG-Step). Availability of nuclear power and/or carbon capture and sequestration offers more low carbon resources for GHG mitigation and lowers costs relative to scenarios where these technologies are not available.

Among all GHG scenarios, *Included Instate* emissions in 2035 range from 235 to 320 MMTCO<sub>2</sub>e, though some of these scenarios do not quite achieve the 80% reduction level by 2050. Including emissions from out-of-state transport (*Overall Instate* emissions) makes reducing emissions by 80% much more difficult as the aviation and marine sectors are among the hardest to decarbonize and require more low-carbon biofuels.

### *Electric sector:*

The GHG scenarios all exhibit dramatic growth in electricity demand because of electrification of many energy services currently supplied by natural gas and petroleum fuels (overall demand grows to between 550 and 666 TWh in these scenarios). The emissions from the electric sector also decline significantly as generation comes primarily from low to zero carbon resources. The primary GHG scenarios (GHG-Step and GHG-Line) exhibit

rapid growth in wind and solar power so that by 2050 approximately 102 GW of solar capacity and 74 GW of wind produce around 438 TWh of electricity generation. Generation from solar and wind are prevalent in the GHG scenarios, producing 54% to 80% of generation in 2050 in the GHG scenarios. This level of wind and solar penetration requires very large investments and ramp up of capacity in California and neighboring states. If nuclear power and/or natural gas with CCS are available then the use of intermittent renewables is lessened. In all GHG scenarios the carbon intensity of electricity falls dramatically (from around 360 g/kWh to between 2 and 29 g/kWh) by 2050.

### ***Transportation sector:***

The transportation sector reduces GHG emissions through a combination of high efficiency, advanced drivetrain technologies (electric and fuel cell) and low-carbon transportation fuels. Even with population and travel demand growth, transportation fuel demand drops in all GHG scenarios (from 10 to 30% lower than BAU) from 2010 to 2050 to between 19 to 25 billion GGE due to significant efficiency improvements in all transport sectors. Battery and fuel cell powered vehicles make up between 50% and 90% of light duty vehicles fleet in most GHG scenarios and the LDV fuel economy climbs as high as 113 MPGGE in many scenarios. However, scenarios with availability of CCS and negative carbon biofuels have much lower adoption of electric-drive technologies (~10%) due to the ability to make significant GHG reductions through low-carbon fuels alone. In most GHG scenarios, the mix of fuels changes dramatically from 95% petroleum based fuels in 2010 to around 40-65% in 2050, when including out-of-state marine and aviation fuel usage (*Overall Instate* fuel use). The remaining fuels are biomass, electricity and hydrogen. Petroleum fuel makes up only 2% to 37% of *Included Instate* fuel use, as petroleum makes up 100% of uncapped out-of-state transport emissions. Petroleum usage is highest when CCS is available, primarily because biofuels production coupled with CCS can provide significant offsets to petroleum usage (and other hard to mitigate emissions). Biomass is almost exclusively used to make biofuels in our scenarios, where the expected quantity available for California is around 7-8 billion GGE. The marginal gallon of biofuels produced displaces an equivalent amount of petroleum-based fuel (gasoline, diesel, jet or RFO), while use of biofuels in electricity displaces lower carbon options, including natural gas electricity generation. Transportation demand reduction is a key element in the GHG emissions reductions strategies, especially in light of the continued use of petroleum and limited supply of liquid biofuels. Note this analysis does not account for unpriced co-benefits related to health impacts and quality of life.

### ***Residential and commercial sectors:***

The residential and commercial sectors reduce GHG emissions through a combination of high efficiency and increasing reliance on low-carbon electricity (i.e., electrification). The share of residential and commercial sectors energy use coming from electricity increases under the GHG scenarios. Electricity use in 2050 makes up between 69% to 92% of commercial sector final energy use and 39% to 63% of residential sector final energy in the GHG scenarios compared to 37% (residential) and 53% (commercial) in the Reference scenario. Sector-wide weighted efficiency is a factor of 2.7 to 4.4x higher in 2050 than 2010 for the commercial sector and 3.2 to 4.3x higher in the residential sector.

### ***Demand reduction:***

The elastic demand scenarios attempt to model more realistic consumer behavior given price increases related to GHG mitigation. The scenario results suggest that there are large potential savings in GHG emissions that can be achieved with demand reduction. We model elasticity with two bounding scenarios, one in which the reduced demand leads to reduced investments in expensive advanced technology and another where the technology capacities/numbers are unchanged. However, there are also real consumer utility losses associated with demand reduction, but it is not entirely clear how to value these costs relative to actual monetary costs associated with purchasing low-carbon fuels or efficient technologies. Similarly, VMT reduction can lead to substantially lower mitigation costs compared with scenarios without VMT reduction. However, reducing VMT may require investments in infrastructure, such as walking and bike lanes, public transit systems, and consumer welfare losses.

When we lower VMT in both BAU and GHG scenarios, then overall mitigation costs will be higher as the free GHG savings from the VMT reduction are not included in the cost calculation.

***Energy system and GHG mitigation costs:***

Achieving a 75% reduction in GHG emissions in 2050, as seen in the two primary GHG scenarios requires cumulative undiscounted additional annual expenditures (above spending in the BAU scenarios) of between \$314 billion to \$1.2 trillion between 2010 and 2050. 2013 gross state product is \$2 trillion. These additional costs for GHG emissions mitigation in the primary GHG scenarios amount to between \$139 and \$614/resident/yr undiscounted or -\$5 and \$177/resident/yr discounted from 2010 to 2050. Electricity sector costs account for the biggest cost differential between the BAU and GHG scenarios. These costs ramp up after 2020 to nearly \$30 billion/yr in 2050 in the primary GHG scenarios. The difference in fuel supply costs between the primary GHG and BAU scenarios is relatively low (~\$9 billion/yr in 2050) since high efficiency and alternative fuels leads to displacement of high priced petroleum fuels

Making more low-cost, low-carbon resources available for use in California will lower mitigation costs (as seen by GHG-S-CCS, GHG-S-Nuclear, GHG-S-HiRen, GHG-S-HiBio scenarios). Energy system costs are lowest in the elastic demand scenarios (if you exclude the cost of consumer utility loss) because lower demand requires less fuel use and makes GHG mitigation easier. From a technology perspective, the availability of CCS yields the lowest system costs, because of the effects described previously. The generation of negative emissions in the production of biofuels with CCS, enables continued emissions (and requires less investments in advanced technologies) in the most expensive to mitigate sectors.

The cost of emissions reduction in GHG scenarios will vary depending on which BAU scenario is being compared. The average costs of cumulative GHG reduction from the BAU scenario varies between -\$95 (not including \$77 in loss of consumers' utility) to \$18/tonne CO<sub>2</sub>e with 4% discount rate compared with BAU; and -\$21(not including \$104 in loss of consumers' utility) to \$124/tonne CO<sub>2</sub>e with 4% discount rate compared with BAU-LoVMT. While these costs capture most but not all costs associated with mitigating GHGs (such as ignoring the cost of efficiency and technology changes in the industrial and agricultural sectors, and infrastructure investments to lower VMT), they also do not capture all of the benefits associated with lower energy use, pollution and GHG mitigation.

### **8.3 Future work**

Analysis of scenarios of the future energy system of California are needed in order for policymakers to assess the technology options and policy mechanisms needed to bring about these major energy transformations. These scenarios and system assessments need to continue to be refined and improved, and the recommendations for future work lie in these modeling improvements as well as linkages to other areas of interest, such as water usage and air quality impacts.

Future CA-TIMES model improvements are already being planned but implementation will depend on funding, resource and personnel availability. Some high-priority research areas include:

#### **Near-term (Next year)**

We have a project that is currently assessing the criteria pollutant emissions and concentration changes from climate policies and the CA-TIMES scenarios. PhD candidate Christina Zapata is working on spatial allocation of emission associated with future energy systems to assess exposure and health impacts associated with changes in air quality.

We are also looking at the water use impacts of the future electricity mix and transport fuels in order to understand how water use may change as a result of California's climate policy and national biofuel policies. This

research is based upon CA-TIMES scenarios and analyzes lifecycle water use of current and future transport fuel and electricity consumption to evaluate impacts and formulate mitigation strategies for the state at the watershed scale.

### **Medium-term (1-3 years)**

These next set of future work ideas are those that we have identified as being of value and relate to specific improvements and updates to the core CA-TIMES model.

- Incorporate some spatiality for certain parts of the model (i.e., transportation) to account for the regional locations of criteria emissions and/or fuel infrastructure requirements
- Improve representation of natural gas technology in transportation (vehicle technology characterization, fuel infrastructure, and costs in demand sectors).
- Model the industrial sector endogenously: incorporating demands for energy services and technologies (with associated cost and performance data) to enable the model to make decisions about GHG mitigation.
- Improve understanding and approaches for modeling elastic demand including issues surrounding changes in investments as a result in demand reductions
- Improve representation of travel demand to better incorporate travel demand shifts and reduction as explicit GHG mitigation options.
- Apply the model to support more detailed policy analysis, particularly tangible policies implemented/considered by CARB and CEC.

### **Long-term (3-5 years)**

These longer term ideas involve more ambitious ideas about the future direction of CA-TIMES modeling analysis. These ideas will likely take more effort but could have significant benefits for policymakers.

- Better represent consumers' behaviors and business investment decisions in a non-linear optimization model. We plan to incorporate the insights we have learned from the consumer vehicle choice model (COCHIN-TIMES) into the core CA-TIMES model. But more research is still needed to better understand and implement consumers' behaviors and business investment decisions.
- Continue to explore geographic/spatial modeling within the integrated assessment framework to improve critical infrastructure investment decisions such as hydrogen infrastructure, CCS, renewable penetration, etc.
- Expand the electricity representation in the model to include the Western Electricity Coordinating Council (WECC) region in order to better model electricity imports and exports and the reliability and pricing of the electricity system under the BAU and GHG scenarios
- Incorporate sustainability constraints such as water availability, siting restrictions related to land use or environmental impacts, etc. into the model.
- Expand the analysis to focus on risk and uncertainty in CA-TIMES. The current model is deterministic and a focus on running the model with uncertain inputs and risk will improve the robustness of the results. One option is to incorporate the XLRM decision analysis framework to conduct more formalized uncertainty and decision analysis:
  - *X: exogenous factors or uncertainties that are outside the control of managers;*
  - *L: management responses or levers that can be implemented by managers;*
  - *R: models that describe the relationships between uncertainties and levers; producing*
  - *M: metrics of performance that can be used to evaluate various management options.*

## 9. REFERENCES

- Allan, A. (2011). Renewable Transportation Fuel for California's Electric-Drive Vehicles. MS, University of California, Davis.
- Amtrak (2010). Amtrak Fact Sheet, Fiscal Year 2010, State of California.
- Bainm, R. (2007). Worldwide Biomass Potential: Technology Characterizations (NREL/MP-510-42467), National Renewable Energy Laboratory.
- Bernstein, M., R. Lempert, D. Loughran and D. Ortiz (2000). The Public Benefit of California's Investments in Energy Efficiency, RNAD. Prepared for the California Energy Commission.
- BTS. (2010). "Bureau of Transportation Statistics: Aviation." from [http://www.transtats.bts.gov/databases.asp?Mode\\_ID=1&Mode\\_Desc=Aviation&Subject\\_ID2=0](http://www.transtats.bts.gov/databases.asp?Mode_ID=1&Mode_Desc=Aviation&Subject_ID2=0).
- CA DOF. (2013). "California Statistical Abstract." from [http://www.dof.ca.gov/html/fs\\_data/STAT-ABS/Toc\\_xls.htm](http://www.dof.ca.gov/html/fs_data/STAT-ABS/Toc_xls.htm).
- CAISO (2013). CAISO Daily Renewables Watch.
- California Department of Finance (2013). Population Projections, 2010-2060.
- California Department of Finance (2013). Report P-1: Summary Population Projections by Race/Ethnicity and by Major Age Groups.
- CARB (2007). California 1990 Greenhouse Gas Emissions Level and 2020 Emissions Limit. ARB Staff Report, California Air Resources Board.
- CARB (2008). Personal Communications with Ben Sharpe. D. McCollum, California Air Resources Board.
- CARB (2009). AB 32 Climate Change Scoping Plan Document.
- CARB (2009). Attachment B: 2050 Greenhouse Gas Emissions Analysis: Staff Modeling in Support of the Zero Emission Vehicle Regulation. Sacramento, CA, California Air Resources Board.
- CARB (2009). California's 1990-2004 Greenhouse Gas Emissions Inventory and 1990 Emissions Level, Technical Support Document, California Air Resources Board.
- CARB (2010). Documentation of California's 2000-2008 GHG Inventory - Index, California Air Resources Board.
- CARB. (2011). "EMFAC Software." from <http://www.dot.ca.gov/hq/env/air/pages/emfac.htm>.
- CARB (2013). California's Greenhouse Gas Inventory by Sector & Activity. Sixth Edition: 2000 to 2011, California Air Resources Board.
- CBC (2009). California Biomass Facilities Reporting System (BFRS), California Biomass Collaborative, University of California, Davis.
- CCST (2011). California's Energy Future e The View to 2050: Summary Report, California Council on Science and Technology.
- CCST (2012). California's Energy Future - Portraits of Energy Systems for Meeting Greenhouse Gas Reduction Requirements, California Council on Science and Technology.
- CEC (2007). California Energy Demand 2008 - 2018: Staff Revised Forecast, Final Staff Forecast, 2nd Edition, publication # CEC-200-2007-015-SF2, California Energy Commission.
- CEC (2009). California Energy Demand 2010-2020 Adopted Forecast, California Energy Commission.
- CEC (2010). Energy Almanac, Weekly Fuels Watch Report, California Energy Commission.
- CEC (2010). Energy Facility Status, Power Plant Projects Since 1996, California Energy Commission.
- CEC (2010). Transportation Energy Forecasts and Analyses for the 2009 Integrated Energy Policy Report (CEC-600-2010-002-SF), California Energy Commission.
- CEC (2011). 2011 Integrated Energy Policy Report, California Energy Commission.
- CEC (2012). CA Energy Almanac: Total Electricity System Power California Energy Commission.
- CEC (2013). California Energy Demand 2014- 2024 Preliminary Forecast, Volume 1: Statewide Electricity Demand, End-User Natural Gas Demand, and Energy Efficiency. Publication Number: CEC-200-2013-004-SD-V1, California Energy Commission, Electricity Supply Analysis Division.
- CPUC (2009). 33% Renewables Portfolio Standard Implementation Analysis Preliminary Results, California Public Utilities Commission.
- CPUC. (2011). "California Renewables Portfolio Standard (RPS) - Current Renewable Procurement Status." 2011, from <http://www.cpuc.ca.gov/PUC/energy/Renewables/index.htm>.

- EIA (2008). 2005 Residential Energy Consumption Survey, Energy Information Administration.
- EIA. (2010). "Natural Gas Delivered to Consumers in California." from <http://www.eia.gov/dnav/ng/hist/n3060ca2a.htm>
- EIA (2010). NEMS Model Files and Assumptions to the Annual Energy Outlook. U.S. Department of Energy, Washington, DC, Energy Information Administration.
- EIA (2010). Petroleum Navigator. Energy Information Administration. U.S. Department of Energy, Washington, DC, Energy Information Administration.
- EIA (2011). Annual Energy Review, U.S. Energy Information Administration.
- EIA (2011). Form EIA-923 Data - Electric Power Plant Data, Energy Information Agency, US Department of Energy.
- EIA (2012). Annual Energy Outlook, United States Department of Energy.
- EIA (2013). Annual Energy Outlook 2013, U.S. Energy Information Administration.
- EIA (2013). Residential Energy Consumption Survey (RECS), U.S. Energy Information Administration.
- EIA. (2013). "State Profiles and Energy Estimates." from <http://www.eia.gov/state/?sid=US>.
- GEA (2012). Global Energy Assessment: Toward a Sustainable Future, International Institute for Applied Systems Analysis and Cambridge University Press.
- Geller, H., P. Harrington, A. H. Rosenfeld, S. Tanishima and F. Unander (2006). "Policies for increasing energy efficiency: Thirty years of experience in OECD countries." *Energy Policy* **34**: 556-573.
- Gillingham, K. and K. Palmer (2013). Bridging the Energy Efficiency gap: Insights for Policy from Economic Theory and Empirical Analysis. Washington, DC, Resources For the Future.
- Greenblatt, J. B. (2013). Estimating Policy-Driven Greenhouse Gas Emissions Trajectories in California: The California Greenhouse Gas Inventory Spreadsheet (GHGIS) Model, Lawrence Berkeley National Laboratory.
- Greene, D., J. German and M. Delucchi (2009). Fuel Economy: The Case for Market Failure. *Reducing Climate Impacts in the Transportation Sector*. D. S. a. J. Cannon, Springer Science.
- Greene, D. L. (2011). "Uncertainty, loss aversion, and markets for energy efficiency." *Energy Economics* **33**(4): 608-616.
- H2A (2005). Hydrogen Production Cost Spreadsheets, Department of Energy Hydrogen Analysis Team (H2A).
- ICF (2010). Modeling of Greenhouse Gas Reduction Measures to Support the Implementation of the California Global Warming Solutions Act (AB32): Energy 2020 Model Inputs and Assumptions, ICF Consulting Canada and Systematic Solutions, Inc.
- IEA (2012). Energy Technology Perspectives 2012 - Pathways to a Clean Energy System, International Energy Agency.
- IPCC (2007). *IPCC Fourth Assessment Report: Climate Change 2007 - The Physical Science Basis*. Cambridge, Intergovernmental Panel on Climate Change, Cambridge University Press.
- ITRON (2006). California Commercial End-Use Survey (CEUS).
- Kesicki, F. and G. Anandarajah (2011). "The role of energy-service demand reduction in global climate change mitigation: Combining energy modelling and decomposition analysis." *Energy Policy* **39**(11): 7224-7233.
- Kreutz, T. G., E. D. Larson, G. Liu and R. H. Williams (2008). Fischer-Tropsch Fuels from Coal and Biomass. Princeton Environmental Institute, Princeton University.
- Long, J. C. S., M. John, J. Greenblatt, M. Wei, C. Yang, B. Richter, B. Hannegan and H. Youngs (2011). *California's Energy Future - The View to 2050*, California Council on Science and Technology.
- Loulou, R. and M. Labriet (2008). "ETSAP-TIAM: the TIMES integrated assessment model Part I: Model structure." *CMS* **5**: 7-40.
- Loulou, R. and D. Lavigne (1996). MARKAL Model with Elastic Demands: Application to Greenhouse Gas Emission Control. *Operations Research and Environmental Management*. C. Carrara and A. Haurie. the Netherlands, Kluwer Academic Publishers: 201- 220.
- Loulou, R., U. Remne, A. Kanudia, A. Lehtila and G. Goldstein (2005). Documentation for the TIMES Model. Part I: TIMES Concepts and Theory, Energy Technology Systems Analysis Programme.
- Loulou, R., U. Remne, A. Kanudia, A. Lehtila and G. Goldstein (2005). Documentation for the TIMES Model. Part III: GCAMS Implementation, Energy Technology Systems Analysis Programme.



- McCarthy, R. (2009). Assessing Vehicle Electricity Demand Impacts on California Electricity Supply (PhD Dissertation). PhD, University of California, Davis.
- McCarthy, R., C. Yang and J. Ogden (2008). California energy demand scenario projections to 2050, Institute of Transportation Studies, University of California, Davis, Research Report UCD-ITS-RR-08-11.
- McCollum, D., C. Yang, S. Yeh and J. Ogden (2012). "Deep greenhouse gas reduction scenarios for California - Strategic implications from the CA-TIMES energy-economic systems model." Energy Strategy Reviews **1**(1): 19-32.
- McCollum, D. L. and C. Yang (2009). "Achieving deep reductions in U.S. transport greenhouse gas emissions: scenario analysis and policy implications." Energy Policy **37**(12): 5580-5596.
- Nelson, J., J. Johnston, A. Mileva, M. Fripp, I. Hoffman, A. Petros-Good, C. Blanco and D. M. Kammen (2012). "High-resolution modeling of the western North American power system demonstrates low-cost and low-carbon futures." Energy Policy **43**(0): 436-447.
- NREL (2013). System Advisor Model. <https://sam.nrel.gov/>.
- O'Neill, B., E. Kriegler, K. Riahi, K. Ebi, S. Hallegatte, T. Carter, R. Mathur and D. Vuuren (2014). "A new scenario framework for climate change research: the concept of shared socioeconomic pathways." Climatic Change **122**(3): 387-400.
- ORNL. (2013). "Freight Analysis Framework Data Tabulation Tool." from <http://faf.ornl.gov/fafweb/Extraction0.aspx>.
- Parker, N. C., Q. Hart, P. Tittman, M. Murphy, R. Nelson, K. Skog, E. Gray, A. Schmidt and B. Jenkins (2010). "Development of a biorefinery optimized biofuel supply curve for the Western United States." Biomass & Bioenergy **34**(11): 1597-1607.
- RETI (2009). Renewable Energy Transmission Initiative: Phase 1B Final Report.
- Rufo, M. W. and A. S. North (2007). Assessment of Long-Term Electric Energy Efficiency Potential in California's Residential Sector, California Energy Commission, PIER Energy-Related Environmental Research. CEC-500-2007-002.
- Searchinger, T., R. Heimlich, R. A. Houghton, F. Dong, A. Elobeid, J. Fabiosa, S. Tokgoz, D. Hayes and T.-H. Yu (2008). "Use of U.S. Croplands for Biofuels Increases Greenhouse Gases Through Emissions from Land Use Change. Supporting Online Material " Science **319**(5867): 1238 - 1240.
- U.S. DOE (2008). Hydrogen Analysis (H2A) Project, U.S. Department of Energy.
- U.S. EIA. (2012). "2009 Residential Energy Consumption Survey (RECS)." from <http://205.254.135.7/consumption/residential/>.
- U.S. EIA (2013). Annual Energy Outlook. Washington DC, U.S. Energy Information Administration.
- U.S. EPA (2008). U.S. Nine Region MARKAL Database Documentation, Air Pollution Prevention and Control Division, National Risk Management Research Laboratory, U.S. Environmental Protection Agency.
- Wei, M., J. H. Nelson, J. B. Greenblatt, A. Mileva, J. Johnston, M. Ting, C. Yang, C. Jones, J. E. McMahon and D. M. Kammen (2013). "Deep carbon reductions in California require electrification and integration across economic sectors." Environmental Research Letters **8**(1): 014038.
- WGA (2009). Western Renewable Energy Zones - Phase 1 Report, Western Governor's Association.
- Williams, J. H., A. DeBenedictis, R. Ghanadan, A. Mahone, J. Moore, W. R. M. III, S. Price and M. S. Torn (2012). "The technology path to deep greenhouse gas emissions cuts by 2050- the pivotal role of electricity." Science **335**(6).
- Yang, C. and J. Ogden (2007). "Determining the lowest cost hydrogen delivery mode." Int J Hydrogen Energy. **32**(2): 268-286.
- Yang, C. and J. M. Ogden (2013). "Renewable and low carbon hydrogen for California – Modeling the long term evolution of fuel infrastructure using a quasi-spatial TIMES model." International Journal of Hydrogen Energy **38**(11): 4250-4265.
- Yeh, S., A. Farrell, R. Plevin, A. Sanstad and J. Weyant (2008). "Optimizing U.S. Mitigation Strategies for the Light-Duty Transportation Sector: What We Learn from a Bottom-Up Model." Environmental Science & Technology **42**(22): 8202–8210.
- Yeh, S. and E. S. Rubin (2012). "A review of uncertainties in technology experience curves." Energy Economics **34**(3): 762-771.

Zhenhong Liu, D. G. (2010). Who Will More Likely Buy PHEV: A Detailed Market Segmentation Analysis. The 25th World Battery, Hybrid and Fuel Cell Electric Vehicle Symposium & Exhibition, Shenzhen, China.

**CONTENT OF APPENDICES (See Appendix document)**

APPENDIX A. COST OF ELECTRICITY GENERATION TECHNOLOGIES..... 125

APPENDIX B. ASSUMPTIONS OF TRANSPORTATION TECHNOLOGY COSTS, EFFICIENCIES, HURDLE RATES, ELASTICITIES, AND GROWTH/CAPACITY CONSTRAINTS..... 131

APPENDIX C. ASSUMPTIONS OF RESIDENTIAL AND COMMERCIAL TECHNOLOGY COSTS, HURDLE RATES, ELASTICITIES, AND GROWTH/CAPACITY CONSTRAINTS..... 137

APPENDIX D. POLICY DESCRIPTIONS FOR CA-TIMES SCENARIOS..... 153

APPENDIX E. MORE DETAILED SCENARIO RESULTS..... 157

APPENDIX F. NON-CORE EXPERIMENTAL TIMES MODELS/SCENARIOS ..... 158

    F.1 HYDROGEN INFRASTRUCTURE MODEL..... 158

*Spatial details of H2TIMES* .....158

*H<sub>2</sub> infrastructure* .....159

*Renewable hydrogen and carbon intensity policy*.....160

*Base case modeling results* .....160

*Future work*.....162

    F.2 CONSUMER VEHICLE CHOICE MODEL ..... 162

*Motivation*.....162

*Methodology*.....163

*Preliminary Results*.....166

*Future improvements needed*.....168

    F.3 PLUG-IN ELECTRIC VEHICLE CHARGING SCENARIOS ..... 168