

Research Report – UCD-ITS-RR-15-19

Modelling and Analysis of Plug-in Series-Parallel Hybrid Medium-Duty Vehicles

December 2015

Hengbing Zhao
Andrew Burke

Modelling and Analysis of Plug-in Series-Parallel Hybrid Medium-Duty Vehicles

Hengbing Zhao¹, Andrew Burke²
University of California, Davis, CA 95616 USA
¹hbzhao@ucdavis.edu, ²afburke@ucdavis.edu

Abstract

The paper studies a series-parallel hybrid powertrain configuration for the medium-duty plug-in hybrid trucks and Volt-like passenger cars. The series-parallel hybrid combines the features of the parallel hybrid and the series hybrid. Series-parallel hybrid powertrains with pre- and post-transmission configuration for the plug-in hybrid medium-duty trucks were modelled and compared with a conventional diesel and a mild/full parallel hybrid with pre-transmission configuration to explore the greatest possible benefit of fuel economy by powertrain hybridization. A control strategy for the series-parallel hybrid vehicle was developed, where the electric motor and the engine can work individually or together, depending on the speed and the power required for driving the vehicle and the state-of-charge (SOC) of the battery. The simulations were performed over the urban drive, highway drive, urban heavy duty drive, and the local parcel delivery drive cycles. The simulation results show that series-parallel are well suited to medium duty parcel delivery vehicle applications within the range of 50-100 miles. The Volt-like PHEV utilized a gasoline engine and the vehicle fuel economies were compared for the series-parallel and single-shaft approaches for various city and highway driving cycles.

Keywords: Series-Parallel HEV, PHEV, Powertrain, Fuel Economy

1 Introduction

Fuel efficiency and GHG emission standards for MD and HD vehicles would reduce fuel consumption and cut carbon pollution to reduce the impacts of climate change. In 2011, the first phase of fuel efficiency and greenhouse gas (GHG) standards for medium- and heavy-duty vehicle was jointly proposed by the U.S. EPA and the Department of Transportation's National Highway Traffic Safety Administration. Under the phase 1 regulations, the nation's fleet of MD and HD trucks will be required to meet fuel efficiency and GHG emission standards for the

first time beginning in model year 2014. Vocational vehicles including delivery trucks, buses, and garbage trucks will be required to reduce fuel consumption and GHG emissions by approximated 10 percent by model year 2018. In 2015, more stringent standards were proposed for the same classes of MD and HD vehicles for model year 2018 and beyond. In phase 2, the new fuel consumption standards would become 2.5% more stringent every year from model years 2021 to 2027. These regulations and standards will spur more innovation and the adoption of advanced vehicle technologies to comply with them.

Various advanced vehicle technologies have been studied and advanced to improve fuel efficiency

[1-8]. Non-electrification efficiency-improving technologies include low temperature and increased peak cylinder pressure engines, high efficient transmissions, waste heat recovery, hydraulic hybrid regenerative braking, vehicle weight reduction, low resistance and wide-based tires, and aerodynamic improvement, etc. Electrification and hybridization efficiency-improving approaches include electrification of mechanical accessories, hybrid electric powertrains, and traction motor and battery technologies. This research studies the hybridization using electric motors and batteries in PHEVs with the conventional engines and explores various architectures for MD vehicles over different duty cycles in term of fuel economy. The baseline MD truck is a 2014 Class 4 conventional diesel delivery truck (stepvan). Series-parallel hybrid powertrains with pre- and post-transmission configuration for the plug-in hybrid medium-duty trucks were modelled and compared with a conventional diesel and a mild/full parallel hybrid with pre-transmission configuration to explore the fuel economy potential of each technology over a wide range of duty cycles. In addition to the MD trucks, the use of the series-parallel approach in the driveline of Volt-like passenger cars was investigated.

There are three basic hybrid electric architectures: parallel, series, and series-parallel. In a parallel hybrid, both the electric motor and the combustion engine are connected to the wheels via a standard transmission and work together to power the vehicle. The electric motor acts as a generator during regenerative braking, and is also used to optimize the engine operation by recharging the battery. The parallel configuration is especially efficient for highway driving and is widely used in hybridization of MD and HD trucks. According to the size of the traction motor, the parallel hybrid can be classified into mild hybrids and full hybrids. In a series hybrid, two electric machines are employed. The engine is not coupled to the wheels and is connected to a separate generator to charge the battery pack. This configuration allows the engine to operate at any optimal operating point and more efficiently. The electric motor, powered by the battery pack and the output of the engine generator as needed, is solely responsible for propelling the vehicle. The electric motor also acts as a generator during regenerative braking. The series powertrain configuration is more efficient in the urban driving with frequent stop-and-go situations. The series hybrid is widely used in transit buses, but is

not attractive for delivery trucks, especially at high vehicle speeds due to the double conversion of engine mechanical energy to/from electric energy. It is not considered in this study. The series-parallel hybrid combines the features of the parallel hybrid and the series hybrid. The electric motor and the engine can work individually or together in parallel or series, depending on the speed and the power required for driving the vehicle and the state-of-charge (SOC) of the battery. The control strategy for the series-parallel hybrid is more complex than either the series or parallel hybrid, but can be more efficient. Figure 1 shows the powertrain architectures that are studied in this research. Depending on the coupling position of the traction motor and the transmission, there are pre-transmission and post-transmission coupled types for parallel and series-parallel hybrids.

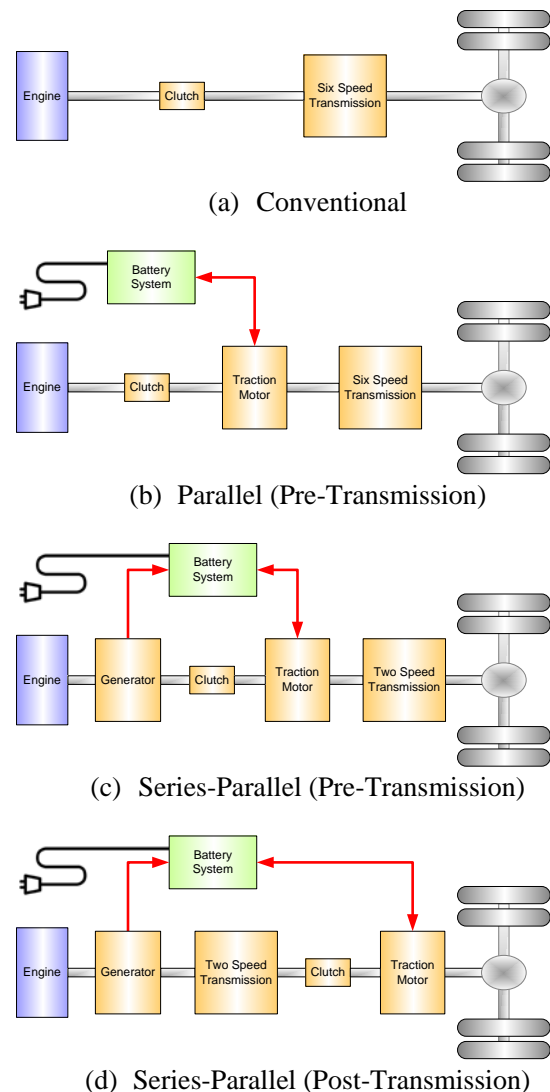

Figure 1: Delivery truck powertrain architectures

This paper presents a comparison between the conventional powertrain, the mild parallel hybrid, the full parallel hybrid, and the series-parallel hybrids with pre- and post-transmission in term of fuel economy. First, the control strategies and their operation modes are presented for various powertrain architectures. Second, the detailed vehicle inputs for a Class 4 delivery van and the vehicle model are described. Third, the simulations are performed and the fuel economy is analysed over various duty cycles. Finally, the results are discussed and conclusions are presented.

2 Control Strategy and Operation Mode

In this section, the control strategies for the parallel hybrid and the series-parallel hybrid are discussed. The operation mode migration for series-parallel is presented.

2.1 Mild Parallel Hybrid

For plug-in hybrid trucks, the performance depends on the rate of hybridization. In a mild parallel hybrid, a small traction motor is usually coupled or integrated with the transmission in pre-transmission configuration. A transmission is on the main drive shaft and the gear shifting affects the performance of both engine and electric drive. When the truck is stopped or moving below a specified speed, it runs in the all-electric mode with, its engine shut off and the clutch disengaged, the battery powering the accessories and the traction motor until the battery is depleted. When the battery SOC is low or the traction motor is at maximum power, the engine is turned on. When the vehicle speed is above the specified all-electric speed, the vehicle runs in parallel hybrid mode. In the hybrid mode, the engine is turned on, runs in the optimal high efficiency region, and propels the vehicle and charges the battery at the same time if required.

2.2 Full Parallel Hybrid

The full parallel hybrid is similar to the mild hybrid in powertrain architecture except employing a full size traction motor. It is able to be propelled on the all-electric mode alone over all speed and power requirements. When the battery is depleted, the vehicle runs in the hybrid mode. In the hybrid mode, the engine is turned on and the battery SOC is maintained within a

narrow range of SOC, while the engine operates at high efficiency.

2.3 Series-Parallel Hybrid

The series-parallel hybrid vehicle has three operation modes: electric mode, series hybrid mode, and parallel hybrid mode, which can be switched in accordance to the vehicle driving conditions and battery SOC. Figure 2 shows the operating modes of a series-parallel hybrid with pre-transmission. Initially the vehicle is propelled by the electric drive alone in the electric mode until the battery reaches the lower limit of the SOC. After that, the engine is turned on and the vehicle switches to either series blended mode or parallel blended mode depending on the vehicle speed.

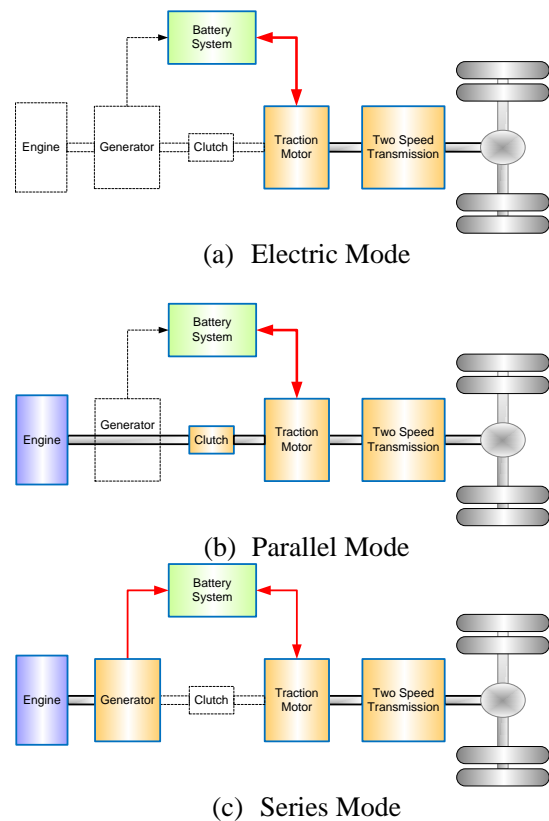

Figure 2: Series-parallel operation modes

In the series blended mode, the clutch is disengaged and the connection between the engine and the main drive shaft is removed. The traction motor is powered by a small generator turned by the engine. The engine operates at its most efficient point at the power that matches the vehicle power demand and the maximum power of the generator, and charges the battery at the same time. The engine is turned off when the

battery reaches specified high limit of the SOC for the blended operation.

When the vehicle speed exceeds the speed threshold in the series operation mode, the vehicle switches to parallel operation via the electric operation mode. The clutch is engaged and the engine is connected to the main drive shaft. The engine operates in the high power efficiency region, propelling the vehicle and maintaining the battery SOC at the same time. Unlike for LD hybrid electric vehicles, optimization control of the engine operation of MD trucks is less important on the parallel operation mode because the engine operates near optimum efficiency even with a conventional powertrain for high speed vehicle operation.

Besides these three modes, there are two other modes defined in the system control. They are the regenerative braking and stop modes. During braking in the series or parallel blended operation, the engine runs at the minimum power, which avoids frequent engine on/off. Both the engine power and the kinetic braking power are used to charge the battery subject to the battery power limit. In this study, the lower and higher SOC levels are chosen as 0.3 and 0.4 for the blended series and parallel operation. The speed threshold is set to 50 mph. Detailed control strategy and operating mode transformation are given in Figure 3.

3 Vehicle Simulation Inputs

In this study, a typical fully loaded Class 4 delivery truck shown in Figure 4 is modelled. A 2014, 7 litre, 150 kW diesel engine and a PM motor with continuous power of 100 kW and peak power of 150 kW are selected to power the truck. The efficiency maps of the engine and the traction motor are given in Figure 5 and 6. A 45 kW PM motor is used for a mild parallel hybrid in the simulation. A six-speed transmission is employed in the conventional powertrain and parallel hybrid architectures, and a two-speed transmission is used in the series-parallel hybrids. All hybrid powertrains use the same lithium battery pack of 31 kWh and the same engine without downsizing, as shown in Table 1.



Figure 4: Class 4 delivery Truck

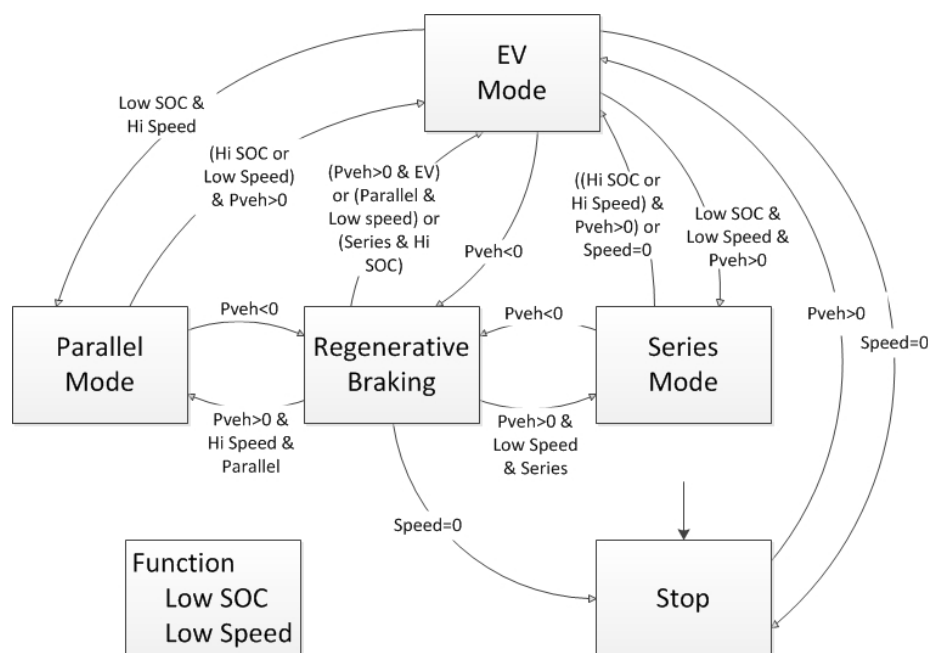

Figure 3: Control strategy of the series-parallel hybrid

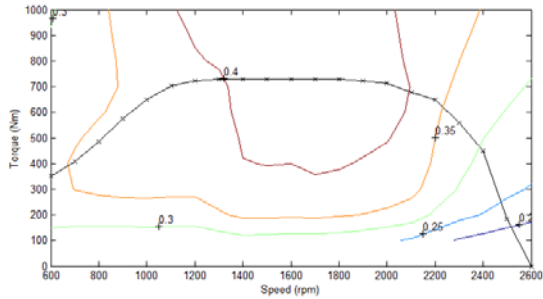

Figure 5: 2014 diesel engine efficiency map

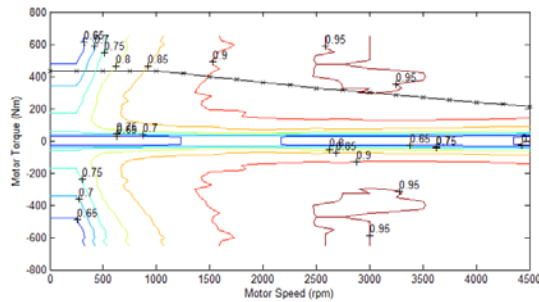

Figure 6: Traction motor efficiency map

Table 1: Vehicle simulation inputs

Engine (2014)	CI Diesel, 7Liter 150 kW
Engine Peak Eff.	0.43
Frontal Area	7.8 m ²
Air Drag Coef.	0.6
Weight	7,257 kg
Wheel Radius	0.378 m
Rolling Res. Coef.	0.006
Traction Motor (PM)	100kW cont. 150kW peak 45 kW for mild parallel
Generator	PM 71 kW
Energy Storage	31 kWh (22 kW usable)
Gearbox	6-Speed for conven. & parallel 2-Speed for series-parallel
Final Drive	2.85
Aux. Mechanical	1
Aux. Electrical	0.4

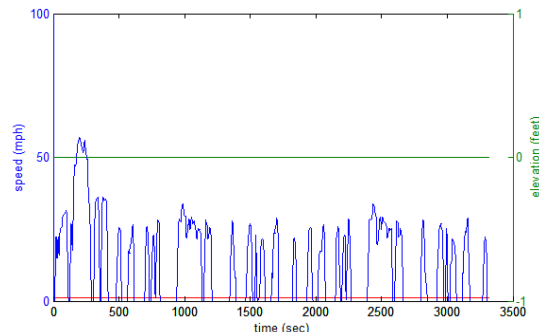

Figure 7: HTUF-4 local business parcel delivery cycle

The following driving cycles are used in the simulations: the EPA Urban Dynamometer

Driving Schedule (UDDS) representing city driving conditions for light duty vehicle testing, the EPA Heavy Duty Urban Dynamometer Driving Schedules (UDDS-HDV) for heavy duty vehicle testing, and the Highway Fuel Economy Driving Schedule (HWFET) representing highway driving conditions under 60 mph, and the Hybrid Truck Users Forum Class 4 (HTUF-4) represents local business parcel delivery cycles for Class 4 delivery trucks. The HTUF-4 drive cycle has an average speed of 21 mph, maximum speed 57 mph, and is plotted in Figure 7.

4 Simulation and Discussion

4.1 Medium-Duty Truck

The purpose of this study is to model and compare different powertrain architectures and explore the potential of improving fuel economy over various duty cycles. Simulations were performed on the Class 4 delivery vans over the UDDS, UDDS-HEV, HWFET, and the HTUF-4 driving cycles. The powertrain architectures simulated are conventional, mild parallel hybrid, full parallel hybrid, and series-parallel hybrid with pre- and post-transmission configurations. The baseline vehicle is a Class 4 2014 diesel delivery truck. In the simulations, the vehicle weight and the auxiliary loads remain constant as shown in Table 1. As for a plug-in electric vehicle, a 31 kWh battery is used for all hybrid powertrain simulations.

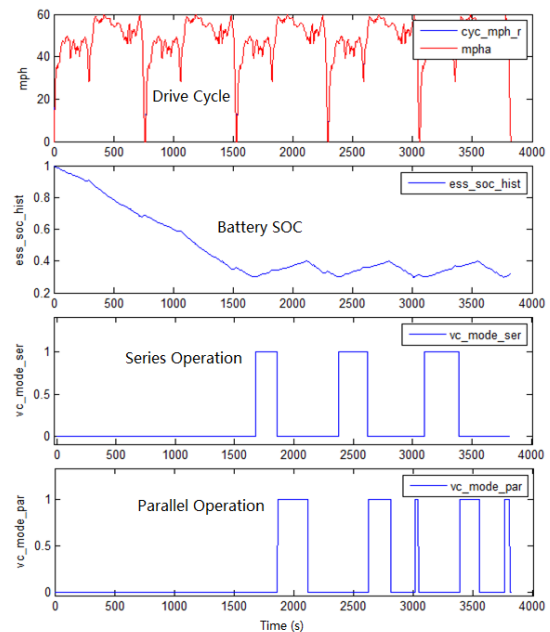

Figure 8: Simulation over the short distance highway drive

Figure 8 shows the change of the battery SOC and the operation mode of a series-parallel hybrid for a short distance highway drive. When the battery is depleted (the battery SOC reaches 0.3), the vehicle switches from the electric mode to the series mode, then to the parallel mode when the vehicle speed is over 50 mph. The battery is charged during series and parallel operation. When the battery SOC reaches 0.4 the vehicle switches back to the electric operation mode.

To compare the driveline efficiency of different hybrid powertrain architectures, the simulation is first done with initial battery SOC starting at 0.3. The battery is completely depleted and the hybrid vehicle operates in charge sustaining mode. The battery SOC is maintained between 0.3 and 0.4. The simulated fuel economy, normalized to the baseline vehicle, is plotted in Figure 9. The fuel economies of the conventional baseline vehicle on the various driving cycles are the following: UDDS 11.6 mpg, UDDS-HDV 11.1 mpg, HWY 14.2 mpg, HTUF 10.5 mpg. The simulation results show that the series-parallel powertrain has higher efficiency over the UDDS-HDV and the HTUF-4 drive cycles. Both drive cycles feature stop-go with a short distance of high speed drive. Therefore, the series-parallel powertrain is well suited for a typical Class 4 delivery truck running over the heavy duty urban drive and the local parcel delivery drive cycles. Compared to the parallel hybrid, the series-parallel hybrid achieves 10 – 20 percent improvement over the UDDS-HDV and the HTUF-4 drive cycles. In term of driveline efficiency, there is no apparent difference between the mild parallel, full parallel, and series-parallel architectures for a Class 4 delivery truck operating in the charge sustaining mode over the light duty urban drive cycle and the highway drive cycle.

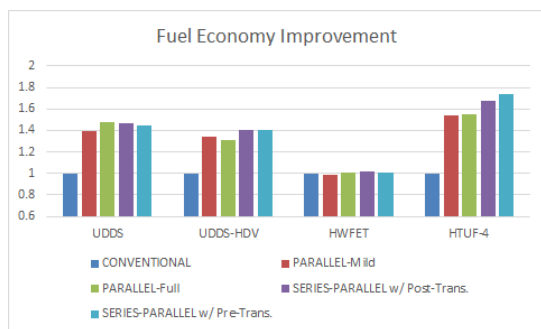

Figure 9: Normalized fuel economy for charge sustaining operation

Since many Class 4 delivery trucks travel less than 30 miles daily, the 30 kWh battery pack can cover most of the daily drive. The daily drive of a Class 4 truck can be broken up into two scenarios: short daily distance – up to 50 miles and long daily distance – up to 100 miles or longer, which includes almost all Class 4 vocational truck applications. The simulations were performed with the initial battery SOC starting at 1.0 for both scenarios over the UDDS, UDDS-HEV, HWFET, and the HTUF-4 drive cycles. The actual fuel economy (distance travelled / fuel used) for the 50-mile and 100-mile trips is given in Figure 10 and 11, respectively. Compared to the conventional truck, the series-parallel hybrid shows improved fuel economy by a factor of 3-3.5 for the UDDS-HEV and HTUF-4 drive cycles. With the increase of the daily distance travelled, the improvement in fuel economy levels off for the series-parallel hybrids. Compared to other hybrids, the mild parallel hybrid has less improvement in fuel economy since the size of the traction motor limits the usage of battery electricity.

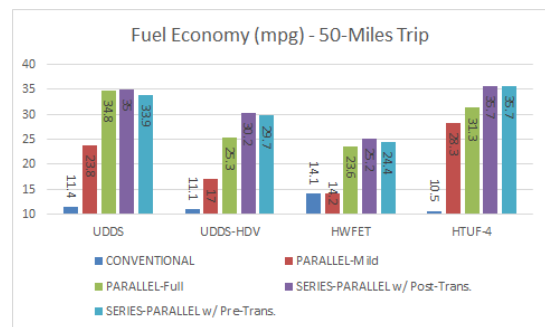

Figure 10: Actual fuel economy for a 50-mile trip

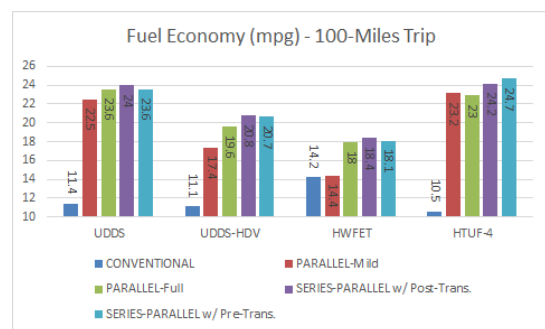

Figure 11: Actual fuel economy for a 100-mile trip

4.2 Mid-Size Passenger Car (Volt-like)

The Chevrolet Volt utilizes a series –parallel powertrain configuration and operates as a series

hybrid at relatively low speeds and as a parallel hybrid at highway speeds. It is of interest to compare the fuel economies of vehicles with the same weight and road load characteristics of the Volt, but using different powertrain configurations than the Volt. *Advisor* simulations were run for hybrid vehicles using the series-parallel, single-shaft PHEV, and HEV powertrain configurations and the conventional engine-powered Chevrolet Cruze on which the Volt is based. The control strategies for the series-parallel hybrid powertrain are discussed in a previous section of this paper. The control strategies for the charge-sustaining HEV powertrains are discussed in [9]. For the single-shaft hybrids in the hybrid mode of operation, the electric motor/generator is used as a traction motor when the vehicle power demand would result in low efficiency operation of the engine (low torque). In that case, the engine power is increased by charging the battery in addition to meeting the vehicle power demand. This results in the engine operating near its peak efficiency most of the time. The battery is sized so that its roundtrip efficiency for charge/discharge from charging and regenerative braking is greater than 85%. The powertrain component characteristics for the various powertrain options are shown in Table 2. The powertrain components for the series-parallel and single-shaft PHEVs are the same. However,

the Cruze HEV utilizes a smaller electric motor and higher power engine than the PHEVs. The conventional Cruze utilizes the engine power used by GM in the marketed vehicle. The battery characteristics were scaled from test data [10] for an EIG lithium NiCo cell tested at UC Davis. The engine map used in the simulation was for a Civic 1.8L iVTEC engine.

The results of the simulations are shown in Table 3. Results are given for three driving cycles – the UDDS (city driving), the HWFET (highway driving at relatively low speeds-50 mph max), and the HW-Interstate (freeway driving at speeds up to 75 mph). The electrical energy use (Wh/mi) and all-electric range are given for the PHEVs. The fuel economy (mpg) is given for all the vehicles when they are operating in the hybrid mode with the engine-on as needed. For the PHEV vehicles, this occurs when the battery is discharged to SOC =0.25. For the HEV vehicles, the SOC is maintained near 50%. The calculated acceleration times for the PHEVs are 0 - 30 mph in 2.8 seconds and 0-60 mph in 8.4 seconds. The all-electric energy uses are consistent with EPA test data and on the road values experienced by Burke in his 2015 Volt. The fuel economy values calculated for the PHEVs are significantly higher than both the EPA data and those experienced by Burke in his 2015 Volt.

Table 2: Vehicle component characteristics for various powertrain configurations

Vehicle	Powertrain	Engine kW	EM kW	Battery kWh	Generator eff.
Volt	Series-Par PHEV	65	111	17	.95 (65 kW)
Volt	Single-shaft PHEV	65	111	17	.95 (65 kW)
Cruze	HEV single-shaft	105	20	1.8	---
Cruze	Convention.	122	NA	---	---

Table 3: Energy characteristics of mid-size cars with various powertrain configurations

Vehicle	Powertrain	Drive cycle	Wh/mi electric	Range electric-miles	mpg engine
Volt	Series-Par PHEV	UDDS	212	52	49
		HWFET	240	46	43
		HW-Interst.	296	37	36
Volt	Single-shaft PHEV	UDDS	206	54	48
		HWFET	228	48	43
		HW-interst.	289	38	35
Cruze	HEV single-shaft	UDDS	---	---	45
		HWFET	---	---	45
		HW-interst.	---	---	37
Cruze	Convention.	UDDS	---	---	25
		HWFET	---	---	37
		HW-interst.	---	---	34

The road values were 36-38 mpg depending on the vehicle speed. The reason for this discrepancy is likely to be the idealized character of the control strategy used in the simulations that results in the engine operating quite near peak efficiency (31-32% compared to a peak efficiency of 35%). This would indicate that there is considerable room for improvement in the Volt. In fact, the 2016 Volt is reported [11] to have a fuel economy of 42-43 mpg.

Of special interest is the comparison of the hybrid mode fuel economy for vehicles using the series-parallel and single-shaft powertrain arrangement. The simulations indicate that the two power train options and their associated control strategies yield close to the same fuel economies on all three driving cycles for the PHEVs. As expected, the electric energy use in the all-electric mode for the two PHEVs is essentially the same. The simulation results for the HEV Cruze indicate a large improvement in fuel economy with a relatively low power motor/generator and small battery (1.8 kWh). This is consistent with previously published results [9] by UC Davis using the same control strategy employed in this study. All the results are consistent with the trends discussed previously in this paper for medium-duty trucks.

It appears from the results of this study that the major advantage of the series-parallel approach to PHEV design is that the control of the operation of the vehicle in the all-electric mode is simple and straight forward just like an EV. Hence GM refers to the Volt as a range-extended EV. The disadvantage is that it will take very careful engineering to get optimum fuel economy when a series-parallel vehicle is operated in the series hybrid or parallel coupled modes. The present design (2015) of the Volt appears to get less than optimum fuel economy in both modes.

5 Conclusion

This research performed modeling and fuel economy analysis of medium-duty trucks and a PHEV Volt-like passenger car with various powertrain architectures. The research for the medium-duty trucks included the conventional powertrain, the mild and full parallel hybrid, and the series-parallel hybrids with pre- and post-transmission architectures, and simulated a fully-loaded delivery truck over the UDDS, HWFET, UDDS-HEV, and HTUF-4 drive cycles. The

research found that duty cycles and daily miles travelled are critical in selecting vehicle technology. Series-parallel hybrid powertrains are well suited to medium-duty parcel delivery vehicle applications. Compared to the full parallel hybrid, the series-parallel hybrid can achieve 14 percent improvement in fuel economy for the short daily distance. The improvement will level off with long daily distance travelled.

The PHEV Volt-like passenger car research compared the electric energy consumption and the fuel economy for the series-parallel and single shaft PHEV configurations and control strategies and the fuel economy of the single-shaft sustaining hybrid (HEV) and the conventional engine-powered vehicles on the UDDS, Federal Highway, and Highway-Interstate driving cycles. In the case of the PHEVs, it was found that the differences in the energy consumptions and fuel economies for the series-parallel and single-shaft powertrain configurations were small. The advantage of the series-parallel approach seems to be primarily related to vehicle drivability and design/control simplicity.

Acknowledgments

The authors gratefully acknowledge the support of the Sustainable Transportation Energy Pathways program of the Institute of Transportation Studies.

References

- [1] R. A., Barnitt, A. D., Brooker, L. Ramroth. *Model-based analysis of electric drive options for medium-duty parcel delivery vehicles*. The 25th World Battery, Hybrid and Fuel Cell Electric Vehicle Symposium & Exhibition, November 5-9, 2010, Shenzhen, China.
- [2] Z. Du etc. *Fuel Economy Comparisons of Series, Parallel and HMT Hydraulic Hybrid Architectures*, 2013 American Control Conference (ACC), Washington, DC, USA, June 17-19, 2013
- [3] L.A. Ramroth, J.D. Gonder, A.D. Brooker, *Assessing the Battery Cost at Which Plug-in Hybrid Medium-Duty Parcel Delivery Vehicles Become Cost-Effective*, SAE 2013

World Congress & Exhibition, 2013-01-1450, 2013, doi:10.4271/2013-01-1450

- [4] W. Xiong, C. Yin, *Design of Series-Parallel Hybrid Electric Propulsion Systems and Application in City Transit Bus*, WSEAS Transactions on Systems, Vol.8, Iss.5, May 2009
- [5] J. Park, etc. *Real-Time Powertrain Control Strategy for Series-Parallel Hybrid Electric Vehicles*, SAE Technical Paper 2007-01-3472, 2007, doi:10.4271/2007-01-3472
- [6] T.E. Reinhart, *Commercial medium- and heavy-duty truck fuel efficiency technology study - Report #1*. (Report No. DOT HS 812 146). Washington, DC: National Highway Traffic Safety Administration. June 2015.
- [7] H. Zhao, A.F. Burke, M. Miller, *Analysis of Class 8 truck technologies for their fuel savings and economics*, Transportation Research Part D 23 (2013) 55–63
- [8] R. Ghorbani, etc. *Modeling and Simulation of a Series Parallel Hybrid Electric Vehicle Using REVS*, American Control Conference, 9-13 July 2007. DOI: 10.1109/ACC.2007.4282828
- [9] H. Zhao, A.F. Burke, *Effects of Powertrain Configurations and Control Strategies on Fuel Economy of Fuel Cell Vehicles*, EVS-25, Shenzhen, China, November 2010
- [10] A.F. Burke, M. Miller, *Performance Characteristics of Lithium-ion Batteries of Various Chemistries for Plug-in Hybrid Vehicles*, EVS-24, Stavanger, Norway, May 2009
- [11] <http://gm-volt.com> *Finally: Next Generation 2016 Volt, full specifications*, November 2015

Authors



Hengbing Zhao, Project Scientist, ITS-Davis, University of California – Davis, 1605 Tilia Street, Davis, CA 95616, USA. Tel.: +1 (530) 754-9000 Email: hbzhao@ucdavis.edu

He received his Ph.D. at Zhejiang University in 1999. His research has involved many aspects of battery electric vehicles, fuel cell vehicles, hybrid electric vehicles, distributed power generation systems, and intelligent electric vehicle charging stations. His particular interests are vehicle hybridization, applications of batteries and ultracapacitors for electric vehicles, and renewable fueling/charging stations.



Andrew Burke, Research faculty ITS-Davis, University of California – Davis, 1605 Tilia Street., Davis, CA 95616, USA. Tel.: +1 (530) 752-9812

Email: afburke@ucdavis.edu Ph.D., 1967, Princeton University. Since 1974, Dr. Burke's research has involved

many aspects of electric and hybrid vehicle design, analysis, and testing. He was a key contributor on the US Department of Energy Hybrid Test Vehicles (HTV) project while working at the General Electric Research and Development Center. He continued his work on electric vehicle technology, while Professor of Mechanical Engineering at Union College and later as a research manager with the Idaho National Engineering Laboratory (INEL). Dr. Burke joined the research faculty of the ITS-Davis in 1994. He directs the EV Power Systems Laboratory and performs research and teaches graduate courses on advanced electric driveline technologies, specializing in batteries, ultracapacitors, fuel cells and hybrid vehicle design. Dr. Burke has authored over 80 publications on electric and hybrid vehicle technology and applications of batteries and ultracapacitors for electric vehicles.